



ISSN NO. 2320-5407

Journal Homepage: - www.journalijar.com

INTERNATIONAL JOURNAL OF ADVANCED RESEARCH (IJAR)

Article DOI: 10.21474/IJAR01/2250
DOI URL: <http://dx.doi.org/10.21474/IJAR01/2250>



INTERNATIONAL JOURNAL OF
ADVANCED RESEARCH (IJAR)
ISSN 2320-5407
Journal homepage: <http://www.journalijar.com>
Journal DOI: 10.21474/IJAR01

RESEARCH ARTICLE

MODELING OF PHOTOVOLTAIC SYSTEM AND UNIFIED POWER FLOW CONTROLLER.

Apurva A. Bhalerao¹ and Prof. Pritee R. Rane².

1. Student, EE Department, P.R.Pote COET, Maharashtra, India.
2. Assistant Professor, EE Department, P.R.Pote COET, Maharashtra, India.

Manuscript Info

Manuscript History

Received: 29 September 2016
Final Accepted: 30 October 2016
Published: November 2016

Key words:-

FACTS; Photovoltaic power station;
power flow analyze; unified power flow
controller

Abstract

The mutation of solar irradiance can cause the output power of photovoltaic power plant to mutate, and it takes great changes to active power and reactive power which feed into the power grid. When the system security constraint is exceeded, the photovoltaic power plant will stop running. In this paper, the structure and the mathematical model of large grid-connected photovoltaic power plant are introduced; then an improved double loop PI decoupling control system is proposed based on UPFC parallel converter. On the basis of traditional PI control, DC load current is directly used as feed-forward control in the control system of capacitor voltage. It is not only easy to get feedback, but also conducive to design and operate the series controller and the parallel controller independently. Finally, this paper sets up a Simulink model of UPFC in the environment of Matlab/Simulink after analyzing its principle. And then, this model was applied into a three-phase system to observe its influences to power quality. The simulation results show that this control system based on the UPFC can effectively control the voltage and the power flow, maintain bus voltage and reduce reactive exchange. It can also improve the active photovoltaic power transmission, as well as maintaining the stability of the system. H[11]

Copy Right, IJAR, 2016,. All rights reserved.

Introduction:-

FACTS technologies involve conversion and switching of power electronics in last few decades. The deregulation and competitive environment in the contemporary power networks will imply a new scenario in terms of load and power flow condition and so causing problems of line transmission capacity. But, now a day some problems exist to change the present structure of transmission system. So, the need for new power flow controllers capable of increasing transmission capacity and controlling power flows through predefined transmission corridors will certainly increase. Today's power systems are highly complex and require careful design of new devices taking into consideration the already existing equipment, especially for transmission systems in new deregulated electricity markets. Blackouts have put network reliability on top of agenda. Improvement will require combination of technical and regulatory improvements. This is not an easy task considering that power engineers are severely limited by economic and environmental issues. V[5] Thus, this requires a review of traditional methods and the creation of new concepts that emphasize a more efficient use of already existing power system resources without reduction in system stability and security. Since a new approach to solve the problem of designing and operating power systems; the proposed concept is known as Flexible AC Transmission Systems (FACTS)

Corresponding Author:- Apurva A. Bhalerao and Prof. Pritee R. Rane

Address:- Student, EE Department, P.R.Pote COET, Maharashtra, India, Assistant Professor, EE
Department, P.R.Pote COET, Maharashtra, India.

Its first concept was introduced by N.G Hingorani, in 1988. Since then different kinds of FACTS devices have been proposed. Flexible Alternating Current Transmission System or FACTS is a technology introduced by Electrical Power Research Institute (EPRI) in the 80s. Its principle role is to increase the transmission capacity of the ac lines and to control power flow over designated transmission to few hundred megawatts. New solid state self commutating devices such as MOSFETs, IGBTs, GTOs and also other suitable power electronic devices are used as controlled switches in FACTS devices. The universal and most flexible FACTS device is the Unified Power Flow Controller (UPFC).

Mathematical Modeling of Grid Connected Photovoltaic Power Plant:-

Large grid-connected photovoltaic power plant is an important developing direction of photovoltaic power generation. Because the PV power plant's generating capacity varies with temperature, irradiance and other changes, when it is in the larger proportion of the grid, the intermittent and abrupt will cause the fluctuations and changes of power flow. So, the difficulty of voltage adjustment in the power grid is increased.

PV arrays are built up with combined series/parallel combinations of PV solar cells, which are usually represented by a simplified equivalent circuit model such as the one given in Fig. 1 and/or by an equation as in (1).

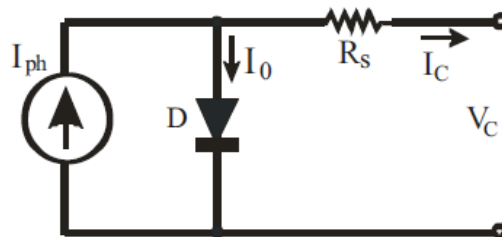

Fig-1: Simplified Circuit of Photovoltaic Cell

The PV cell output voltage is a function of the photo current that mainly determined by load current depending on the solar irradiation level during the operation.

$$V_c = \frac{AKT_c}{e} \ln \left(\frac{I_{ph} + I_0 - I_c}{I_0} \right) - R_s I_c \text{----- (1)}$$

Where the symbols are defined as follows:

e: electron charge (1.602×10^{-19} C).

k: Boltzmann constant (1.38×10^{-23} J^o K)

I_c: cell output current, A.

I_{ph}: photocurrent, function of irradiation level and junction temperature (5 A).

I₀: reverse saturation current of diode (0.0002 A).

R_s: series resistance of cell (0.001 Ω).

T_c: reference cell operating temperature (20 °C).

V_c: cell output voltage, V.

Both k and T_c should have the same temperature unit, either Kelvin or Celsius. If the temperature and solar irradiation levels change, the voltage and current outputs of the PV array will follow this change. Hence, the effects of the changes in temperature and solar irradiation levels should also be included in the final PV array model. A method to include these effects in the PV array modeling is given by Buresch.

According to this method, for a known temperature and a known solar irradiation level, a model is obtained and then this model is modified to handle different cases of temperature and irradiation levels. The solar cell operating temperature varies as a function of solar irradiation level and ambient temperature. The variable ambient temperature T_a affects the cell output voltage and cell photocurrent. These effects are represented in the model by the temperature coefficients C_{TV} and C_{TI} for cell output voltage and cell photocurrent, respectively, as:

$$C_{TV} = 1 + \beta_T (T_a - T_x)$$

$$C_{TV} = 1 + \frac{\gamma_T}{\beta_C} (T_x - T_a)$$

Where, $\beta_T = 0.004$ and $\gamma_T = 0.06$ for the cell used and $T_a = 20^\circ\text{C}$ is the ambient temperature during the cell testing. Even if the ambient temperature does not change significantly during the daytime, the solar irradiation level changes depending on the amount of sunlight and clouds. A change in solar irradiation level causes a change in the cell photocurrent and operating temperature, which in turn affects the cell output voltage.

Thus the change in operating temperature and in the photocurrent due to variation in the solar irradiation level can be expressed via two constants, CSV and CSI, which are the correction factors for changes in cell output voltage VC and photocurrent Iph, respectively:

$$C_{SV} = 1 + \beta_T \alpha_S (S_x - S_c)$$

$$C_{SI} = 1 + \frac{1}{S_c} (S_x - S_c)$$

S_c = Benchmark reference solar irradiation level during the cell testing.

S_x = New level of solar irradiations

The change in temperature due to change in solar irradiation level is given by ΔT_c

$$\Delta T_c = \alpha_S (S_x - S_c)$$

The constant α_S represents the slope of the change in the cell operating temperature due to a change in the solar irradiation level and is equal to 0.2 for the solar cells used. Using the correction factors the new value of cell output voltage and current are obtained for new temperature and solar irradiation are as follows:

$$V_{CX} = C_{TV} C_{SV} V_C$$

$$I_{PhX} = C_{TI} C_{SI} I_{PH}$$

V_C and I_{ph} are the benchmark reference cell output voltage and reference cell photocurrent, respectively. A[10]

PVA Mathematical Modeling for Simulink:-

A general block diagram of the PVA model for GUI

Environment of Simulink is as shown. The block contains the sub models that are connected to build the final model.

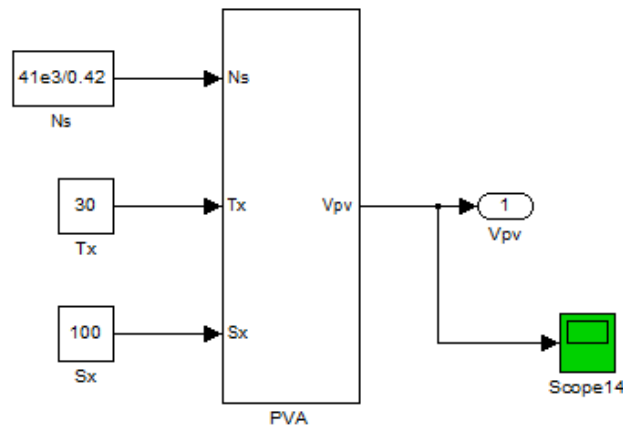

Fig- 1.2.1: Final mathematical model of simulink

Fig 1.2 shows the final PVA mathematical model in simulink which contains different subsystems which satisfies the mathematical equations of grid connected PV system. The effects of the temperature and solar irradiation levels are represented by two variables gains. They can be changed by dragging the slider gain adjustments of these blocks named as variable temperature and variable temperature solar irradiation. The submask of fig 1.2.1 is given by figure 1.2.2.

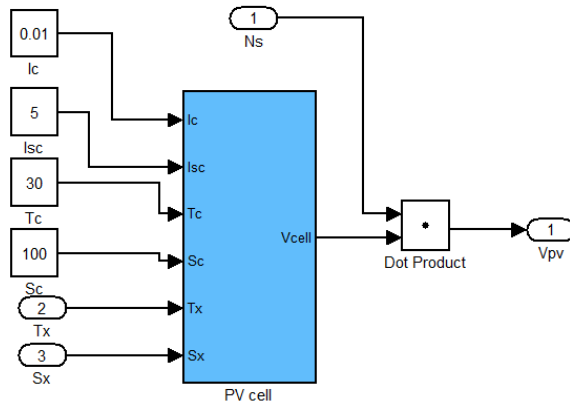

Fig-1.2.2: Modeling Stage 2

The subsystem of PV cell given by figure 1.2.3 and the final sub mask of PV cell and Subsystem 1 is given by Fig 1.2.4 and 1.2.5 which satisfies all the mathematical equation of grid connected PV cell.

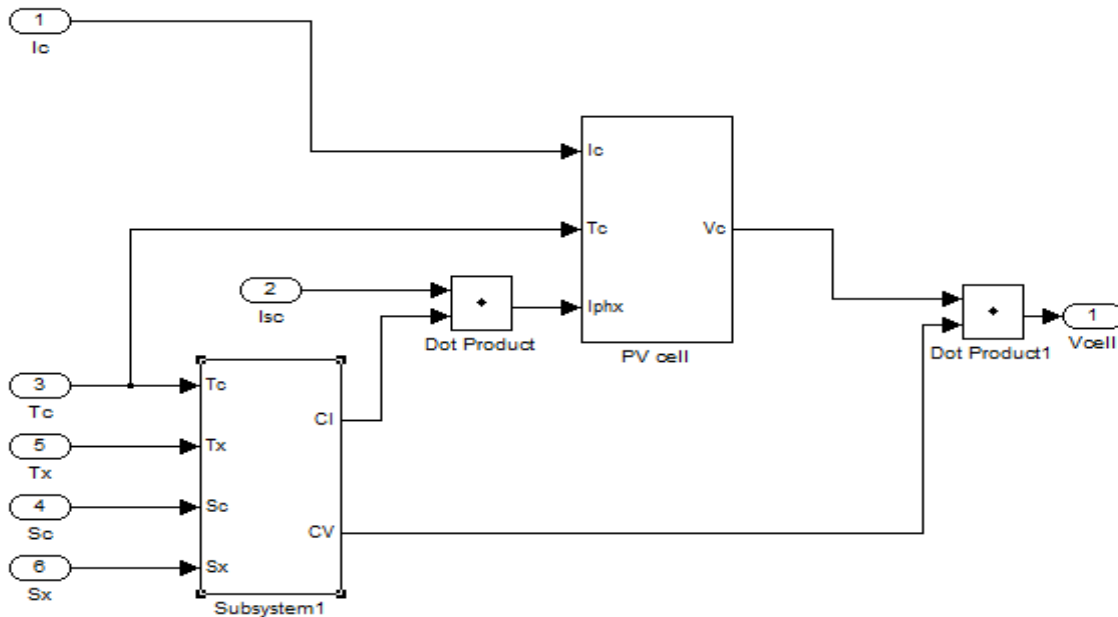

Fig-1.2.3: Modeling Stage 3

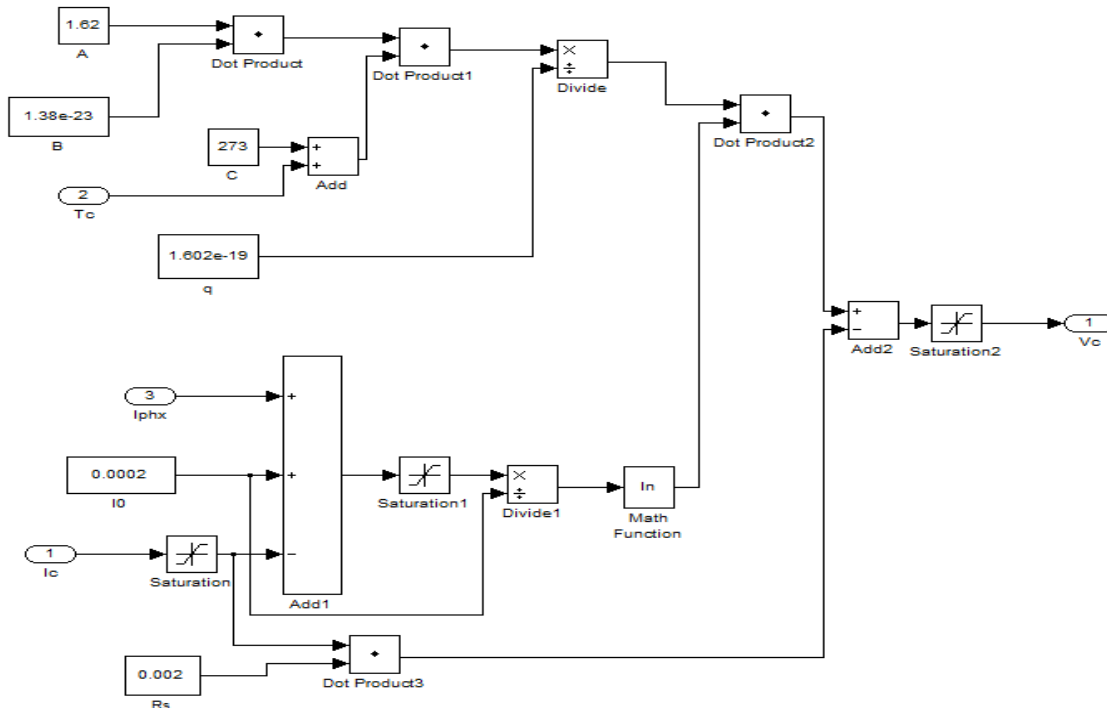

Fig-1.2.4: Mathematical Sub mask system of PV cell

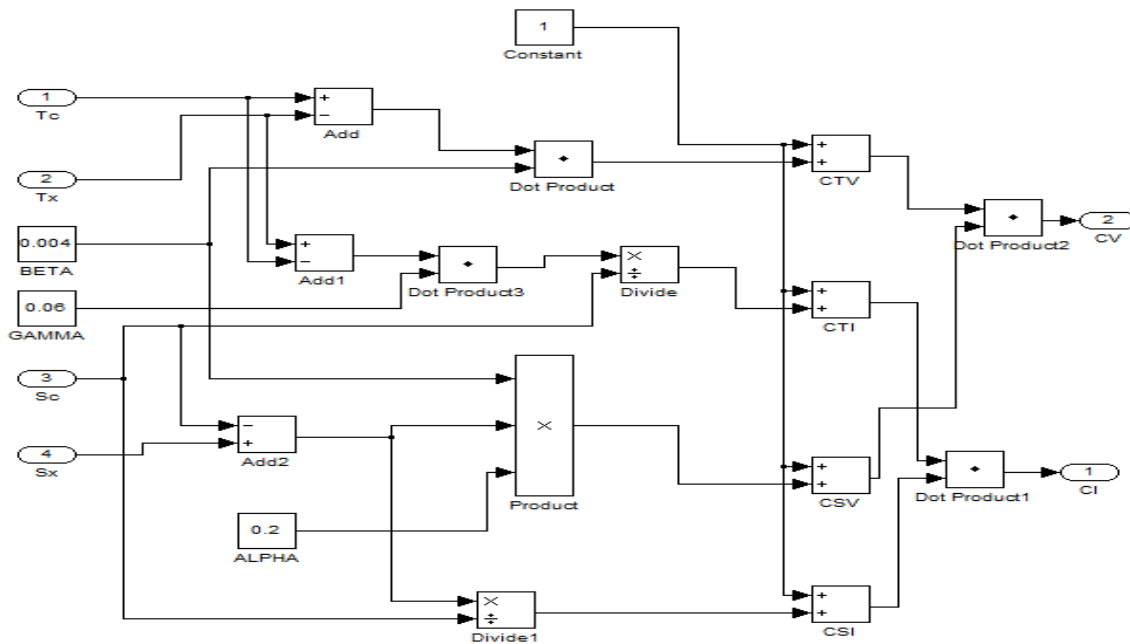

Fig-1.2.5: Mathematical Sub mask system of Subsystem 1

Basic Structure of UPFC:-

The system structure of UPFC is shown in Fig.2. Its core structure is two three-phase PWM inverters. The parallel converter is connected to the grid through the parallel transformer T1 while the serial converter is connected to the grid through the series transformer T2 . The series converter supply the power grid with series voltage U_2 whose amplitude U_2 and phase α_2 is variable. At the same time, it can regulate the power flow of transmission lines; The Parallel converter supply the incoming end with parallel voltage U_1 whose amplitude U_1 and phase α_1 is variable. It

can stable not only capacitor voltage U_{dc} at DC side but also voltage at incoming end of UPFC. In addition, the parallel control system and the serial control system can be designed and work independently .H[11]

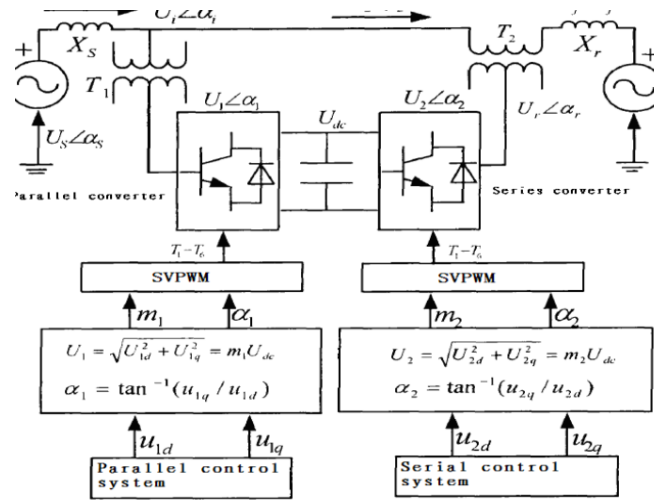

Fig -2: Basic Structure of UPFC connected to power system

Modeling of UPFC:-

Viewing the operation of the unified power flow controller, the general power flow control capability of UPFC from the view point of conventional transmission control, can be illustrated by real and reactive conventional transmission verses transmission angle characteristics of simple two machine system. The real and reactive power supplied b the receiving end ,can be expressed as follows:

$$P-jQ = V_r \left(\frac{V_s + V_{pq} - V_r}{jX} \right)$$

Where symbol * means conjugate of the complex number and $j = e^{j\frac{\pi}{2}} = \sqrt{-1}$. If $V_{pq} = 0$ then it describes uncompensated system that is,

$$P-jQ = V_r \left(\frac{V_s - V_r}{jX} \right)^*$$

Thus $V_{pq} \neq 0$, then total real and reactive power can be written in the form

$$P-jQ = V_r \left(\frac{V_s - V_r}{jX} \right)^* + \frac{V_r V_{pq}}{-jX}$$

Where,

$$V_s = V e^{j\frac{\delta}{2}} = V \left(\cos \frac{\delta}{2} + j \sin \frac{\delta}{2} \right)$$

$$V_r = V e^{-j\frac{\delta}{2}} = V \left(\cos \frac{\delta}{2} - j \sin \frac{\delta}{2} \right)$$

And

$$V_{pq} = V e^{j\left(\frac{\delta}{2} + \rho\right)} = V \left\{ \cos \left(\frac{\delta}{2} + \rho \right) + j \sin \left(\frac{\delta}{2} + \rho \right) \right\}$$

The following expression are obtained for real and reactive power, H [1]

$$P(\delta, \rho) = P_0(\delta) + P_{pq}(\rho) = \frac{V^2}{X} \sin \delta - \frac{V V_{pq}}{X} \cos \left(\frac{\delta}{2} + \rho \right)$$

$$Q_r(\theta, \rho) = Q_{0r}(\theta) + Q_{pq}(\rho) = \frac{V^2}{X} (1 - \cos \theta) - \frac{VV_{pq}}{X} \sin\left(\frac{\theta}{2} + \rho\right)$$

By putting the values we get different values of real and reactive power for compensated and uncompensated system as shown below first table shows the value for uncompensated system i.e $V_{pq} = 0$ and second table shows the value for compensated system i.e $V_{pq} \neq 0$ [1]

Table-1: Value of P & Q for uncompensated system

SR.NO	θ	$P_0(\theta)$	$Q_{0r}(\theta)$
1	0^0	0	0
2	30^0	0.5	-0.1339
3	60^0	0.8660	-0.5
4	90^0	1	-1

Table-2: Value of P & Q for compensated system

SR.NO	θ	$P(\theta, \rho) = P_0(\theta) + P_{pq}(\rho) = \frac{V^2}{X} \sin \theta - \frac{VV_{pq}}{X} \cos\left(\frac{\theta}{2} + \rho\right)$	$Q_r(\theta, \rho) = Q_{0r}(\theta) + Q_{pq}(\rho) = \frac{V^2}{X} (1 - \cos \theta) - \frac{VV_{pq}}{X} \sin\left(\frac{\theta}{2} + \rho\right)$
1	0^0	-6.25	0
2	30^0	6.46	-1.731
3	60^0	16.237	-9.375
4	90^0	20.58	-20.5805

Conclusions:-

The UPFC can effectively control the voltage and the power flow, maintain bus voltage and reduce reactive exchange. It can also improve the active photovoltaic power transmission, as well as maintaining the stability of the system. It can reduce reactive power exchange between power system and photovoltaic power plant. It improves both the delivery limits of active power from the PV power plant and power system's stability and security.

References:-

1. Narain.G.Hingorani,Laszlo,Gyugyi,“Understanding FACTS Concepts and Technology of Flexible AC Transmission Systems”, IEEE Press, Standard Publishers Distributors, Delhi. pp.297-308
2. K. R Padiyar, “FACTS Controllers in Power Transmission and Distribution”,NewAge International Publishers (formerly Wiley Eastern Limited), New Delhi.Transmission Systems, IEEE Press, 2000
3. D P Kothari,I J Nagrath,“Modern Power System Analysis”(Third Edition).publicatin
4. David Houcque “INTRODUCTION TO MATLAB FOR ENGINEERING STUDENTS”,North western University (version 1.2, August 2005)New York, NY: IEEE Press, 2000
5. Vibhor Gupta “Study and Effects of UPFC and its Control System for Power Flow Control and Voltage Injection in a Power System”, International Journal of Engineering Science and Technology,Vol. 2(7), 2010, 2558.
6. C. L. Wadhwa , “Electrical Power Systems”, New Age International Publishers, 2009
7. Ashfaq hussain,“Electrical Power System”,aligad university,vol 2, 2009
8. Maryam Hashemi. “Using UPFC in order to control power flow.IEEE International Conference on Industrial Technology”, 2006, 2:1486-1491.
9. Singh S N, Erlich I. Locating unified power flow controller for enhancing power system load stability. International Conference on Future Power System, 2005, 1: 16-18.
10. H. Altas1, and A.M. Sharaf,“A Photovoltaic Array Simulation Model for Matlab-Simulink GUI Environment”, 1-4244-0632-3/07©2007, IEEE
11. Hu Xiaoqing, Cheng Qiming,“ Application of UPFC Based on Improved Double-loop Decoupling PI Control in Photovoltaic Systems”, 2012 International Conference on Computer Distributed Control and Intelligent Environmental Monitoring,978-0-7695-4639-1/12,2012,IEEE,DOI 10.1109/CDCIEM.2012.43