



Journal Homepage: - www.journalijar.com
**INTERNATIONAL JOURNAL OF
 ADVANCED RESEARCH (IJAR)**

Article DOI: 10.21474/IJAR01/2576
 DOI URL: <http://dx.doi.org/10.21474/IJAR01/2576>



RESEARCH ARTICLE

IMAGE DENOISING BY WAVELET TRANSFORM FOR MIXED NOISE.

*Kishan Shivhare¹, and Gaurav Bhardwaj².

1. M. Tech. Student, RJIT BSF Academy, Tekanpur (M.P.).
2. Asst. Prof., ECE Department, RJIT BSF Academy, Tekanpur (M.P.).

Manuscript Info

Manuscript History

Received: 27 October 2016
 Final Accepted: 25 November 2016
 Published: December 2016

Key words:-

Discrete Wavelet Transform, Wavelet Thresholding, Mixed Noise, SNR, PSNR, SSIM, MSE, RMSE.

Abstract

Image denoising is a very familiar technique which is used to remove the all unwanted noises from the original image. There are various methods to remove noise from digital images. In this paper we use Discrete Wavelet Transform for this purpose. In wavelet transform, there are two types of thresholding – Hard thresholding and Soft thresholding. We take a building image to describe the denoising process. First we add different types of noises in our image and then we apply the different thresholdings of DWT. We also use combination of both thresholdings in this paper to denoise the noisy image. To compare the denoised images with the noisy image, we take some performance parameters which are as follows; Signal to Noise Ratio (SNR), Peak Signal to Noise Ratio (PSNR), Mean Square Error (MSE), Root Mean Square Error (RMSE), and Structural Similarity Index (SSIM). We use MATLAB for simulation purpose.

Copy Right, IJAR, 2016,. All rights reserved.

Introduction:-

Image denoising retains the details of an image by removing unwanted noise. Digital images become noisy when these are passed by a defective sensor or when these are transmitted through a faulty medium. To select a suitable denoising technique, we should have a good knowledge about the noise present in the image. The wavelet denoising technique is most suitable to speckle noise so it is generally used to denoise the speckle noise. But in this paper we use wavelet transform method to denoise mixed noise. To obtain mixed type of noise, we combine here three different types of noises. Only single thresholding is not enough capable to denoise the mixed noise, whether it is soft or hard thresholding. Therefore we use a combination of both of thresholdings, which is satisfactory to remove mixed noise.

Noise is a random variation of image Intensity and visible as grains in the image. It may arise in the image as effects of basic physics-like photon nature of light or thermal energy of heat inside the image sensors.

Here we are discussing three types of noise and their effects on the image signal.

1. Salt and pepper noise
2. Speckle noise
3. Gaussian noise

Salt-and-pepper noise is also called impulsive noise or spike noise. Salt-and-pepper noised image has dark pixels in bright area and bright pixels in dark area of the image. It is similar to a binary system because it has only a high

Corresponding Author:- Kishan Shivhare.

Address:- M. Tech. Student, RJIT BSF Academy, Tekanpur (M.P.).

value and a low value. This noise strikes during analog-to-digital converter errors, bit errors in transmission. Salt-and-pepper noise can damage the information or data embedded in the original image. One of the simplest ways to remove salt-and-pepper noise is by windowing the noisy image with a conventional median filter. The probability density function (pdf) for impulsive noise is given by:

$$F(g) = \begin{cases} P_a, & g = a \\ P_b, & g = b \\ 0, & \text{otherwise} \end{cases}$$

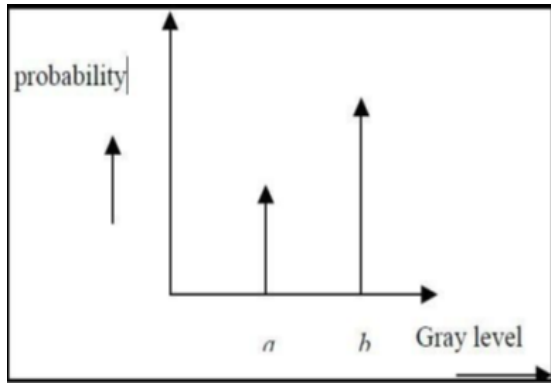

(a) Graphical representation



(b) Example

Figure 1:- Salt and Pepper noise.

Speckle noise has an inherent nature of ultrasound images, which may have negative effects on image interpretation and diagnostic tasks. Speckle noise degrades the image quality and complicates diagnostic decisions for discriminating fine details in ultrasound images. Speckle noise is a kind of multiplicative noise. Speckle-noise is a granular noise which degrades the quality of the active radar, synthetic aperture radar (SAR), and medical ultrasound images. Speckle noise is seen in conventional radar due to random fluctuations while getting return signal from an object. Speckle noise follows a gamma distribution and is given as: -

$$F(g) = \frac{g^{\alpha-1}}{(\alpha-1)! a^\alpha} e^{-\frac{g}{a}}$$

where $a^{2\alpha}$ = variance, g = gray level

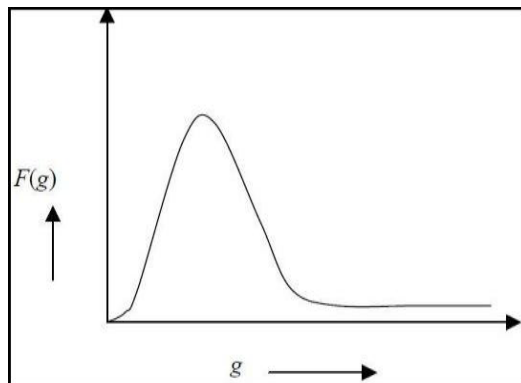

(a) Graphical representation



(b) Example

Figure 2:- Speckle noise

Gaussian noise model is additive in nature. Additive white Gaussian noise (AWGN) is generally caused by poor quality image acquisition, noisy environment or/and internal noise in communication channels. Gaussian noise is statistical noise. It has a probability density function (pdf) equal to that of the normal distribution, which is also known as the Gaussian distribution. Gaussian noise is uniformly distributed over the signal. It means that each pixel in the noisy image is the sum of the true pixel value and a random value of Gaussian distributed noise. The Gaussian distribution is given by:

$$F(g) = \frac{1}{\sqrt{2\pi\sigma^2}} e^{-\frac{(g-m)^2}{2\sigma^2}}$$

Where g = gray level, m = mean or average of the function, σ^2 = variance of the noise

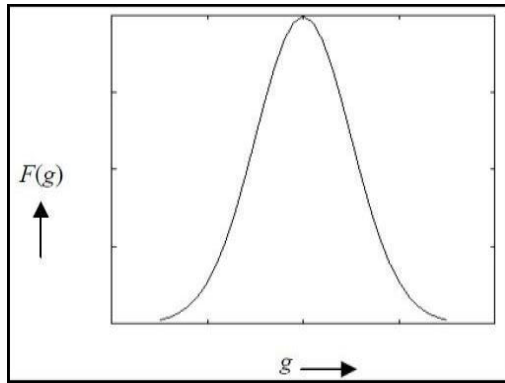

(a) Graphical representation



(b) Example

Fig 3:- Gaussian noise

Discrete Wavelet Transform (DWT):-

Denosing analysis of the images is performed by using Wavelet Transform. Simple denoising algorithms that used DWT consist of three steps;

1. It decomposes the noisy image and produces some coefficients which are called as wavelet coefficients.
2. These coefficients are modified with a particular threshold value.
3. At last Inverse Wavelet transform is applied to the modified coefficients to produce denoised image.

DWT of a noisy image consists two types of coefficients, a small number of coefficients having high SNR and a large number of coefficients having low SNR. These coefficients which are having low SNR are removed in DWT. Using inverse DWT, image is reconstructed after removing the coefficients of low SNR. Wavelet transform provides Time and frequency localization simultaneously. When DWT is applied to any noisy image, image is first divided into four sub bands as shown in Figure 4(a).



(a) One level

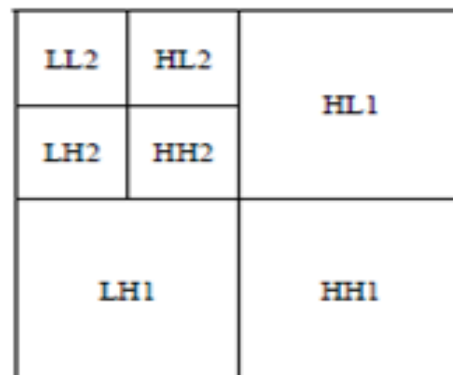

(b) Two level

Fig 4:- Image decomposition by using DWT

These sub bands are formed by separable applications of horizontal and vertical filters. Coefficients of LH1, HL1 and HH1 sub bands are detail images while coefficients of LL1 sub band is approximation image. The LL1 sub band is further decomposed in for sub bands to obtain the next level of wavelet coefficients as shown in Fig. 4(b).

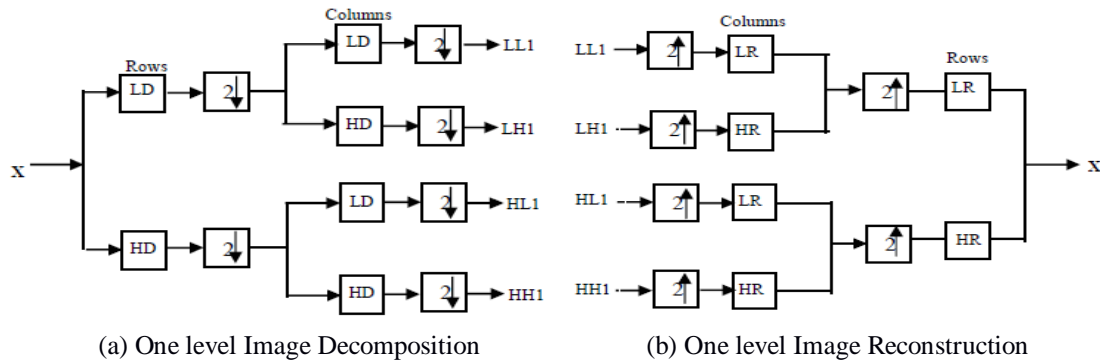

Figure 5:- Wavelet Filter bank

LL1 is called as the approximation sub band because it provides the image similar to original image. It comes by applying low pass filtering in both directions. The other bands are called as detail sub bands. The filters L and H as shown in Figure 5(a) are one dimensional low pass filter (LPF) and high pass filter (HPF) respectively for image decomposition. HL1 is horizontal fluctuation as it comes from low pass filtering in vertical direction and high pass filtering in horizontal direction. LH1 is vertical fluctuation as it is opposite to HL1. HH1 comes from high pass filtering in both the directions so it is called diagonal fluctuation. LL1 is further decomposed into 4 sub bands LL2, LH2, HL2 and HH2. The process is carried until the fifth decomposition level is reached. After L decompositions a total of $D(L) = 3 \cdot L + 1$ sub bands are obtained. Therefore for 5 level decompositions $D(5) = 3 \cdot 5 + 1 = 16$ sub bands will be obtained. The decomposed image can be reconstructed by inverse discrete wavelet transform as shown in Figure 5(b). In figure 5(b) the filters L and H represent low pass and high pass reconstruction filters respectively.

Wavelet Thresholding:-

Thresholding technique operates on wavelet coefficients. It uses one of the wavelet coefficients at a time. In this process the coefficient which is smaller than the threshold value is set to zero otherwise the coefficient is kept or may be modified.

If the coefficient has small value then it carries more noise than a large valued coefficient. While if it has large value then coefficient carries more signal information than small valued coefficients. Therefore noise coefficients or small valued coefficients below a certain threshold value are replaced by zero and for remaining coefficients, an inverse wavelet transform is taken for reconstruction that has lesser noise.

Firstly wavelet analysis of a noisy image up to level N is done with thresholding of the each detail coefficients from level 1 to N and then signal is synthesized by using the altered detail coefficients from level 1 to N and approximation coefficients of level N.

There are two types of thresholding;

1. Hard thresholding technique,
2. Soft thresholding technique.

Hybrid Thresholding:-

Hybrid thresholding is a combination of two thresholdings i.e. Soft and Hard thresholding. The performance of the Soft thresholding is better for noise removal than Hard thresholding but the image get blurred after performing Soft thresholding. The performance of Hard thresholding is not very good for noise removal but the image also does not get blurred. So, there is a need of such technique that can remove mixed noise and produce a good quality image with removal of as possible as value of information of the image during denoising process. Therefore we use hybrid thresholding to combine the properties of both thresholdings.

Steps for designing hybrid thresholding model:

1. A colour image is taken for experiment purpose.
2. The image is converted into gray image.
3. Mixed noise image is obtained by adding three different noises (Gaussian, speckle and salt and pepper noises) at zero mean and different variances.
4. Mixed noise is filtered first by Soft thresholding.
5. The resultant image is filtered by Hard thresholding. This is our final image.

Performance parameters:-

For comparing original building image with different denoised images, we calculate following parameters:

- 1) Mean Square Error (MSE): The MSE is the cumulative square error between the synthesized image and the original image defined by:

$$MSE = \sum_0^{m-1} \sum_0^{n-1} |f(i, j) - g(i, j)|^2$$

Where 'f' is the original image and 'g' is the synthesized image. MSE should be as low as possible.

- 2) Peak signal to noise ratio (PSNR): PSNR is the ratio between maximum possible power of a signal and the power of distorting noise which affects the quality of the original signal. It is defined by:

$$PSNR = \frac{20 \log_{10}(MAX_F)}{\sqrt{MSE}}$$

Where MAX_F is the maximum signal value that exists in our original image. PSNR should be as high as possible.

- 3) Root mean square error (RMSE): It measures of the differences between value predicted by a model or an estimator and the values actually observed. It is the square root of mean square error. RMSE should be as low as possible.

$$RMSE = \sqrt{MSE}$$

- 4) Structural Similarity Index (SSIM): It is a method for measuring the similarity between two images. The SSIM measure the image quality based on an initial distortion-free image as reference.

$$SSIM = \frac{(2\mu_x\mu_y + C_1)(2\sigma_{xy} + C_2)}{(\mu_x^2 + \mu_y^2 + C_1)(\sigma_x^2 + \sigma_y^2 + C_2)}$$

Where: μ_x is average of x; μ_y is average of y; σ_x^2 is variance of x; σ_y^2 is variance of y; σ_{xy} is covariance of x and y; $C_1 = (k_1L)^2$ and $C_2 = (k_2L)^2$ are two variables to stabilize the division with weak denominator. L is the dynamic range of the pixel-values $k_1 = 0.01$ and $k_2 = 0.03$ by default.

- 5) Signal to noise ratio (SNR): Signal-to-noise ratio is defined as the power ratio between a signal (meaningful information) and the noise (unwanted signal). It should be as high as possible.

$$SNR = \frac{P_{SIGNAL}}{P_{NOISE}}$$

Result and Discussion:-



(a) Original Image



(b) Gray Image



(c) Noisy Image



(d) Denoised Image

Figure 6:- Soft Thresholding.



(a) Original Image



(b) Gray Image



(c) Noisy Image



(d) Denoised Image

Figure 7:- Hard Thresholding



(a) Original Image



(b) Gray Image



(c) Noisy Image



(d) Denoised Image

Figure 8:- Hybrid Thresholding

Table I:- Mixed noise at zero mean and different variances and SNR of different thresholdings

Mixed Noise Variance	SNR			
	Noisy Image	Soft Thresholding	Hard Thresholding	Hybrid Thresholding
0.002	38.9841	42.1835	42.3126	42.1539
0.004	39.0037	42.1909	42.3229	42.1646
0.006	39.0317	42.2025	42.3524	42.1797
0.008	39.0592	42.2158	42.3643	42.1887
0.010	39.0826	42.2351	42.3799	42.2021
0.020	39.2109	42.3034	42.4701	42.6762

Table II:- Mixed noise at zero mean and different variances and PSNR of different thresholdings

Mixed Noise Variance	PSNR			
	Noisy Image	Soft Thresholding	Hard Thresholding	Hybrid Thresholding
0.002	44.7165	47.7896	47.9236	47.7678
0.004	44.7362	47.7781	47.9153	47.7544
0.006	44.7641	47.7657	47.9095	47.7422
0.008	44.7916	47.7532	47.9016	47.7286
0.010	44.8150	47.7420	47.8947	47.7172
0.020	44.9433	47.6895	47.8678	47.6651

Table III:- Mixed noise at zero mean and different variances and SSIM of different thresholdings

Mixed Noise Variance	SSIM			
	Noisy Image	Soft Thresholding	Hard Thresholding	Hybrid Thresholding
0.002	0.02	0.0276	0.0124	0.0097
0.004	0.02	0.0274	0.0119	0.0104
0.006	0.02	0.0273	0.0117	0.0097
0.008	0.02	0.0275	0.0113	0.0098
0.010	0.02	0.0266	0.0110	0.0096
0.020	0.01	0.0248	0.0103	0.0106

Table IV:- Mixed noise at zero mean and different variances and MSE of different thresholdings

Mixed Noise Variance	MSE			
	Noisy Image	Soft Thresholding	Hard Thresholding	Hybrid Thresholding
0.002	17717.75	16532.93	17031.85	16420.46
0.004	17798.01	16561.29	17072.03	16461.07
0.006	17912.99	16605.41	17188.42	16518.42
0.008	18026.84	16656.42	17235.92	16552.88
0.010	18124.21	16730.66	17297.77	16603.91
0.020	18667.56	16995.58	17660.92	16897.81

Table V:- Mixed noise at zero mean and different variances and RMSE of different thresholdings

Mixed Noise Variance	RMSE			
	Noisy Image	Soft Thresholding	Hard Thresholding	Hybrid Thresholding
0.002	133.108	128.5805	130.5061	128.1424
0.004	133.409	128.6907	130.6600	128.3007
0.006	133.839	128.8620	131.1046	128.5240
0.008	134.264	129.0598	131.2856	128.6580
0.010	134.626	129.3471	131.5210	128.8562
0.020	136.629	130.3671	132.8944	129.9916

Conclusions:-

The hybrid thresholding has better results in compare to Soft and Hard thresholding. The values of Mean Square Error (MSE) and Root Mean Square Error (RMSE) are low in Hybrid thresholding and the denoised image is also clear in hybrid thresholding analysis. For the hybrid thresholding the threshold value should be low to keep the image sharp.

References:-

1. **Prateek Kumar and Sandeep Kumar Agarwal, (2015.)**, 'A color Image Denoising by Hybrid Filter for Mixed Noise', *Int. Journal of Current Engineering and Technology*, vol. 5, No.3.
2. **Wei Fan, Kai Wang, François Cayre, and Zhang Xiong, (2015.)**, Median Filtered Image Quality Enhancement and Anti-Forensics via Variational Deconvolution, *IEEE transactions on information forensics and security*, vol. 10, page no. 1076-1091.
3. **Taeyoung Na and Munchurl Kim, Member, IEEE (2014)**, A Novel No-Reference PSNR Estimation Method With Regard to Deblocking Filtering Effect in H.264/AVC Bitstreams, *IEEE transactions on circuits and systems for video technology*, vol. 24. Page no 320- 330.
4. **Yu-Hsin Wang and Pai-Chi Li (2014.)**, SNR-Dependent Coherence-Based Adaptive Imaging for High-Frame-Rate Ultrasonic and Photoacoustic Imaging, *IEEE Transactions on Ultrasonics, Ferroelectrics, and Frequency Control*, vol. 61. Page no 1419- 1432.
5. **Vijayalakshmi. A, Titus.C and Lilly Beulah.H(2014)**, Image Denoising for different noise models by various filters: A Brief Survey, *International Journal of Emerging Trends & Technology in Computer Science (IJETTCS)*, Volume 3,page no 42-45.
6. **Amita Kumari Er. Pankaj Dev Chadha(2014)**, A Survey on Filtering Technique for Denoising Images in Digital Image Processing, *International Journal of Advanced Research in Computer Science and Software Engineering Research Paper* , Volume 4,page no. 612-614.
7. **V. Mahesh, M. Someswara Rao, Ch. Sravani, P. Durgarao, S. Venkatesh (2014)**, An Effective Image Denoising Using Adaptive Thresholding In Wavelet Domain, *Int. Journal of Engineering Research and Application*, Vol. 4, page no. 365-368.
8. **Moussa Olfa and Khelifa Nawr (2014)**, Ultrasound Image Denoising using a Combination of Bilateral Filtering and Stationary Wavelet Transform, *IEEE IPAS'14: international image processing applications and systems conference*, page no. 1-5.
9. **Hui Li Tan, Member, IEEE, Zhengguo Li, Senior Member, IEEE, Yih Han Tan, Member, IEEE, Susanto Rahardja, Fellow, IEEE, and Chuohuo Yeo, Member, IEEE(2013)**, A Perceptually Relevant MSE-Based Image Quality Metric, *IEEE transactions on image processing*, vol. 22, page no 4447-4459
10. **Priyanka Kamboj and Versha Rani(2013)**, A brief study of various noise model and filtering techniques, *Journal of Global Research in Computer Science*, Volume 4, page no. 166-171.
11. **Bhumika Gupta and Mr. Shailendra Singh Negi(2013)**, Image Denoising with Linear and Non-Linear Filters: A REVIEW, *IJCSI International Journal of Computer Science*, Vol. 10, page no. 149-154
12. **Rekha Rani, Sukhbir Singh and Amit Malik(2012)**, Image Denoising Using Hybrid Filter, *International Journal of Innovative Technology and Exploring Engineering (IJITEE)*, Volume-1, page no. 10-13.
13. **Anutam and Rajni (2012)**, Comparative analysis of filtersand wavelet based thresholding methods for image denoising, *International Journal of Computer Applications*, Volume 86, page no 10-13.
14. **Ashok Kumar Nagawat, Sumit Srivastava, Pawan Patidar and Manoj Gupta(2010)**, Image De-noising by Various Filters for Different Noise, *International Journal of Computer Applications*, Volume 9,page no. 45-50.

15. **Jong-Woo Han, Jun-Hyung Kim, Sung-Hyun Cheon, Jong-Ok Kim and Sung-Jea Ko(2010)**, A Novel Image Interpolation Method Using the Bilateral Filter, *IEEE Transactions on Consumer Electronics*, Vol. 56.,page no 175-181
16. **Kenny Kal Vin Toh, Student Member, IEEE, and Nor Ashidi Mat Isa, Member, IEEE (2010)**, Noise Adaptive Fuzzy Switching Median Filter for Salt-and-Pepper Noise Reduction, *IEEE signal processing letters*, vol. 17. Page no 281- 284
17. **Mehul P. Sampat, Member, IEEE, Zhou Wang, Member, IEEE, Shalini Gupta, Alan Conrad Bovik, Fellow, IEEE, and Mia K. Markey, Senior Member, IEEE, (2009)**, *Complex Wavelet Structural Similarity: A New Image Similarity Index*, *IEEE transactions on image processing*, vol. 18. Page no 2385-2401
18. **Mario Mastriani, (2009)**, Denoising and Compression in Wavelet Domain via Projection onto Approximation Coefficients, *World Academy of Science, Engineering and Technology* Vol: 3, page no. 502-512
19. **D.Gnanadurai and V.Sadasivam (2008)** ,An Efficient Adaptive Thresholding Technique for Wavelet Based Image Denoising, *World Academy of Science, Engineering and Technology*, Vol: 2,page no.872-877.
20. **Hossein Rabbani, Mansur Vafadust, Purang Abolmaesumi, Member, IEEE, and Saeed Gazor, Senior Member, IEEE (2008.)**, Speckle Noise Reduction of Medical Ultrasound Images in Complex Wavelet Domain Using Mixture Priors, *IEEE transactions on biomedical engineering*. vol. 55, page no 2152-2160.