



Journal Homepage: -[www.journalijar.com](http://www.journalijar.com)

## INTERNATIONAL JOURNAL OF ADVANCED RESEARCH (IJAR)

Article DOI:10.21474/IJAR01/11466  
DOI URL: <http://dx.doi.org/10.21474/IJAR01/11466>



### RESEARCH ARTICLE

#### DESIGN OF A DEMULTIPLEXER USING DOUBLE BASED NUMBER SYSTEM

K.K.W.A.S Kumara<sup>1</sup>, D.D.A Gamini<sup>2</sup> and K.G.H.A Sanjeewa<sup>3</sup>

1. Department of Mathematics, University of Sri Jayewardenepura, Gangodawila, Nugegoda, Sri Lanka.
2. Department of Computer Science, University of Sri Jayewardenepura, Gangodawila, Nugegoda, Sri Lanka.
3. Department of Mathematics, University of Sri Jayewardenepura, Gangodawila, Nugegoda, Sri Lanka.

#### Manuscript Info

##### Manuscript History

Received: 05 June 2020  
Final Accepted: 10 July 2020  
Published: August 2020

#### Abstract

This paper presents an innovative method for designing a double based demultiplexer. This demultiplexer is designed using binary number system combined with ternary number system. A binary demultiplexer selects one out of  $2^n$  number of output lines and passes the single input to one out of  $2^n$  number of output lines whereas a ternary demultiplexer selects one out of  $3^m$  number of output lines and passes the single input to one out of  $3^m$  number of output lines. We propose a double based demultiplexer that selects one out of  $2^n \times 3^m$  number of output lines and passes the single input to one out of  $2^n \times 3^m$  number of output lines.

Copy Right, IJAR, 2020., All rights reserved.

#### Introduction:-

The demultiplexer is a combinational logic circuit designed to switch one common input line to one of several output lines by the application of a control signal. Demultiplexer is a circuit that has a single input line and more than a single output line. It is used when a circuit requires to send a signal to one of many devices.

It is well known that the binary numerical systems are used in most computers and some people consider about ternary number system also. This paper discusses the double based number system (2, 3), that is the combination of base 2 and base 3. Demultiplexers have been designed using base 2, but no literature could be found on demultiplexers developed by considering both bases together. Observing complexity of today's circuits, it is essential to improve circuits at higher than binary logic system. Therefore, design complexity of circuits can be reduced using higher number systems than binary number system.

#### Binary and Ternary Digits and Logic Gates:

In this section, binary and ternary digits, physical implementation, and binary and ternary logic gates are discussed.

#### Binary and Ternary Digits:

0 and 1, are entitled binary digits in binary number system. In Boolean logic (two valued logic), 0 is reflected as false and 1 as true. 0, 1 and 2, are entitled ternary digits in ternary number system. Three valued logic is an extension of two valued logic. In three valued logic 1 is concerned as True, 0 is concerned as False while, 2 is concerned as Unknown. Here, Unknown means 'undefined', 'neither' or both True and False.

**Corresponding Author:-K.G.H.A. Sanjeewa**

Address:- Department of Mathematics, University of Sri Jayewardenepura, Gangodawila, Nugegoda, Sri Lanka.

Before ternary digit operation, binary digit operation should be considered. In logic, bit 1 intends 3.3 voltage and 0 intends zero voltage while in ternary digit operation bit 1 intends 3.3 voltage, 0 intends zero voltage and 2 intends - 3.3 voltage.

**Binary and Ternary Logic Gates:**

A logic gate is an idealized or physical device implementing a Boolean function, that is, it performs a logical operation on one or more logic inputs and produces a single logic output<sup>[5]</sup>.

In demultiplexer design, NOT gate, AND gate and OR gate are mainly concerned in the case of binary and ternary logic gates. In binary logic gates, the truth value of NOT gate is defined as complement of input, truth value of AND gate is defined as product of inputs of truth values and truth value of OR gate is defined as maximum of inputs of truth values.

In ternary logic gates, truth value of AND gate is defined as minimum of inputs of truth values, truth value of OR gate is defined as maximum of inputs of truth values and truth value of NOT gate is defined as cyclical transformation of input. Since there are several non-cyclical ways to define truth value of NOT gate, according to cyclical and non-cyclical ways, different double based demultiplexers can be implemented.

**Designing Double Based Demultiplexer:**

In this design, we have first desinged BinaryTernary AND gate and BinaryTernary OR gate considering binary and ternary logic gates. Binary NOT gate and ternary NOT gate have been used in this design.  $1 \times 2^m 3^m$  demultiplexer has been designed using BinaryTernary AND gates, binary NOT gates and ternary NOT gates.

**Binary gates:**

In this design, binary NOT gate has been used and  $\mathcal{B}$  symbolizes binary NOT gate. Figure 1 shows binary NOT gate and truth values of binary NOT gate is given in Table 1.

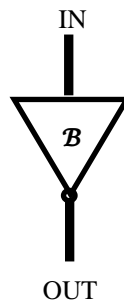

Figure 1:- Binary NOT gate

Tabel 1:-Truth table of binary NOT gate.

IN	OUT
A	$\bar{A}$
0	1
1	0

**Design of Ternary gates:**

Ternary NOT gate has been used here.  $\mathcal{T}$  symbolizes ternary gates. Figure 2 shows cyclic transformation of input system and truth values of ternary NOT gate is given in Table 2.

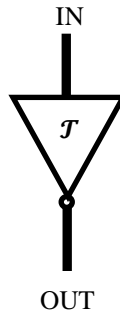

Figure 2:- Ternary NOT gate

According to cyclic or non-cyclic nature of the ternary NOT gate, different double based multiplexers can be designed, but here cyclical transformation of input system has been considered (Figure 3).

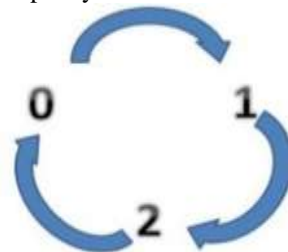

Figure 3:- Cyclical transformation of input system

Table 2:- Truth table of ternary NOT gate.

Input	Cyclical transformation of B	Cyclical transformation of $\tilde{B}$	Cyclical transformation of $\tilde{\tilde{B}}$
B	$\tilde{B}$	$\tilde{\tilde{B}}$	$\tilde{\tilde{\tilde{B}}}$
0	1	2	0
1	2	0	1
2	0	1	2

**Design of Double Based gates:**

In this design, function of AND and OR gates are switched. Output of the BinaryTernary (Double Based) AND gate is always the maximum of the inputs (Table 3), whereas output of the BinaryTernary (Double Based) OR gate is always the minimum of the inputs (Table 4). *BT* symbolizes the BinaryTernary (Double Based) gates<sup>[1]</sup>.

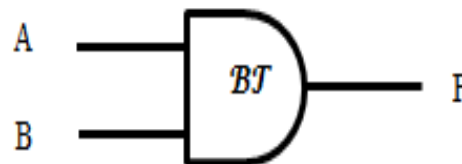

Figure 4:- BinaryTernary AND gate.

Table 3:- Truth table of BinaryTernary AND gate.

A	B	F=Max(A,B)
0	0	0
0	1	1
0	2	2
1	0	1
1	1	1
1	2	2

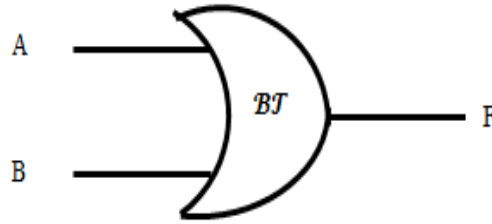

Figure 5:- BinaryTernary OR gate.

Table 4: Truth table of BinaryTernary OR gate.

A	B	F=Min(A,B)
0	0	0
0	1	0
0	2	0
1	0	0
1	1	1
1	2	1

**Block diagram of  $1 \times 2^n 3^m$  Demultiplexer:**

The block diagram shown in Figure 6 gives an overview of how many outputs and selection lines have been used in designing the  $1 \times 6$  demultiplexer. Different combinations of selection lines enable different outputs. Table 5 shows the different values of selection lines and what outputs are enabled in this double based demultiplexer. It consists of a single input and six outputs. According to selection lines, one of six outputs is enabled to pass the input.

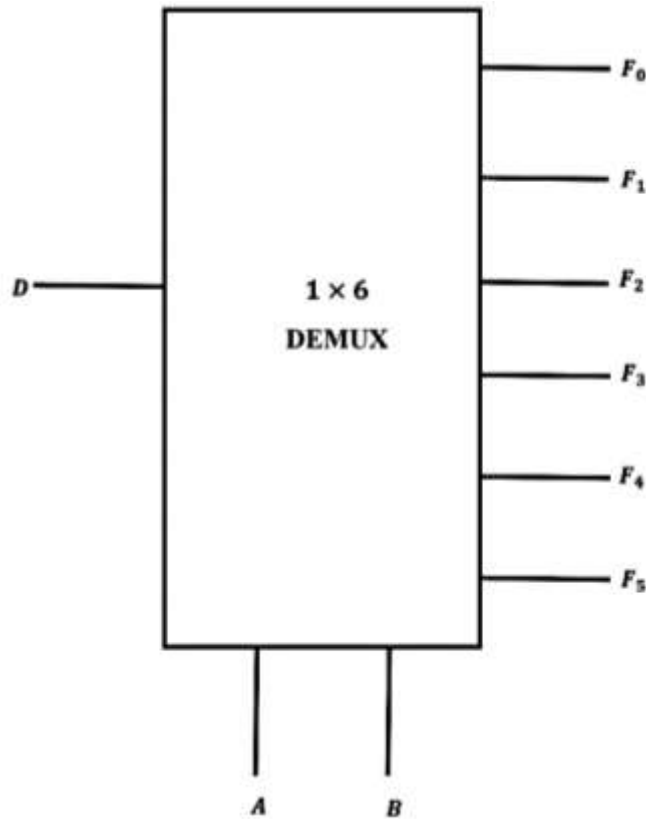

Figure 6:- Block diagram of  $1 \times 6$  Demultiplexer.

**Table 5:-** Truth table of  $1 \times 6$  Demultiplexer.

Input		Output					
A	B	$F_0$	$F_1$	$F_2$	$F_3$	$F_4$	$F_5$
0	0	$D$	0	0	0	0	0
0	1	0	$D$	0	0	0	0
0	2	0	0	$D$	0	0	0
1	0	0	0	0	$D$	0	0
1	1	0	0	0	0	$D$	0
1	2	0	0	0	0	0	$D$

**Design of  $1 \times 6$  Demultiplexer:**

In this design, six BinaryTernary AND gates, two ternary NOT gates, and one binary NOT gate have been used. There are six outputs named  $F_0, F_1, F_2, F_3, F_4$  and  $F_5$ . According to the values of two selection lines  $A$  and  $B$ , one output is enabled (Figure 7). There is a single input labeled  $D$ . According to the values of two selection lines  $A$  and  $B$ , input  $D$  selects one of the outputs.

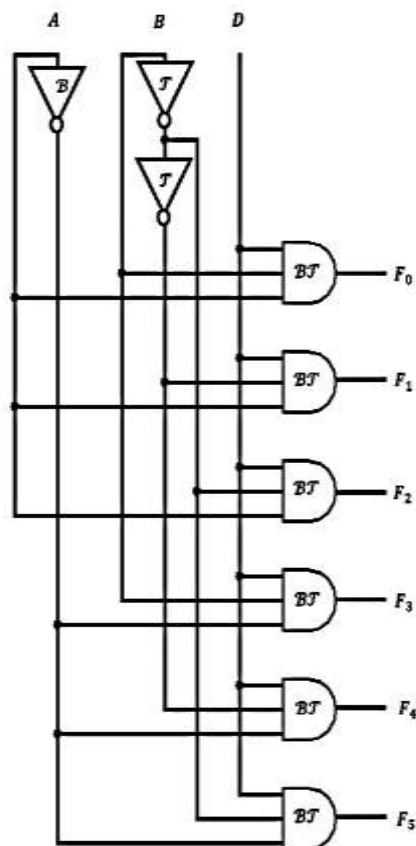
**Figure 7:-** Design of  $1 \times 6$  Demultiplexer.**Conclusion:-**

A new design of a device can be implemented by combining two different logics, two valued logic and three valued logic. Reduction of power consumption of the device is also important. Using the same number of selection lines, different number of outputs can be implemented.

**References:-**

1. Kumara K.K.W.A, Gamini D.D.A, Sanjeeva K.G.H.A (2020) 'Design of a Multiplexer using Double Based Number System' International Journal of Advance Research. 8 pp. 1199-1204.
2. Ion Profeanu (2010) 'A Ternary Arithmetic and Logic' Proceedings of the World Congress on Engineering Vol

I, London, U.K.

3. Arpasi J. (2003) 'A brief introduction to ternary logic' w.w.w.aymara.org, pp. 1–13.
4. Waterworth G. (1988) 'Work Out Electronics', Macmillan Work Out Series, Palgrave, London, Ch. 13, pp.217.
5. What is Multiplexer and De-multiplexer? Types and its Applications?," 14-Apr-2014.[Online].