



ISSN NO. 2320-5407

Journal Homepage: -www.journalijar.com

INTERNATIONAL JOURNAL OF ADVANCED RESEARCH (IJAR)

Article DOI:10.21474/IJAR01/3475/01
DOI URL: <http://dx.doi.org/10.21474/IJAR01/3475/01>



INTERNATIONAL JOURNAL OF
ADVANCED RESEARCH (IJAR)
ISSN 2320-5407
Journal homepage: <http://www.journalijar.com>
Journal DOI:10.21474/IJAR01

RESEARCH ARTICLE

A REVIEW ON IMPLEMENTATION OF MPPT BASED PHOTOVOLTAIC CONVERTER SYSTEM WITH PSO.

Mahajan Jayesh Ramesh¹ and Dr.P.V.Thakre²

1. M.E. (Electrical Power System), Department of Electrical Engineering, SSBTCOET, Jalgaon, Maharashtra, India.
2. Department of Electrical Engineering, Ph. D. (Photovoltaic Systems), M.Tech.(Energy Engineering), SSBTCOET, Jalgaon, Maharashtra, India.

Manuscript Info

Manuscript History

Received: 01 January 2017
Final Accepted: 01 February 2017
Published: March 2017

Key words:-

Maximum Power Point Tracking (MPPT), Perturb & Observe (P&O), Particle Swarm Optimization (PSO), P&O Algorithm.

Abstract

Maximum power point tracking (MPPTs) play a vital role in photovoltaic (PV) power systems as it maximize the output power & efficiency of PV systems. MPPTs are used to find and maintain operation at the maximum power point. Title presents in detail implementation of PSO MPPT using buck-boost converter. Some results such as current, voltage and output power for various conditions can be recorded. The simulation is possible to carried out in MATLAB/SIMULINK software. The results can be obtained and compared with the theoretical operation which confirm the reliability and performance of the proposed model. It is more efficient, accurate, used rapid and low cost technique without need for complicated mathematical operations. This paper presents Particle Swarm Optimization and Perturbation & Observation techniques to find the optimum operating parameters of a solar photovoltaic panel under varying atmospheric conditions. The terminal voltage, current and corresponding duty-cycle, at which the DC/DC converter should be switched to obtain maximum power output, are determined. Simulation of maximum power point tracking of a solar panel is done in MATLAB. It is observed from the results that the particle swarm optimization based algorithm can track the maximum power point for the whole range of solar data (irradiance and temperature) and has high conversion performance.

Copy Right, IJAR, 2017., All rights reserved.

Introduction:-

Solar panels collect the sun's energy and convert it to electrical energy. Unfortunately, the solar output is not consistent throughout the day due to clouds and the sun's angle relative to the position of the solar panel. Addition to this, the intensity of the sun varies according to season and geographical location. Moreover the characteristic curve of a solar cell shows a nonlinear voltage-current relationship [1]. Therefore, a controller i.e. the maximum power point tracker (MPPT) is an crucial part of a photovoltaic (PV) system, to find automatically the maximum power operating point at all environmental conditions and then power the PV system to operate at the point (MPP), to ensure the optimum use of the available solar energy [1-2]. This function is realized by suitably controlling the power processing circuit that is exactly always used as an interface between the PV generator and the load or the

Corresponding Author:-Mahajan Jayesh Ramesh.

Address:- M.E.(Electrical Power System), Department of Electrical Engineering , SSBTCOET, Jalgaon , Maharashtra, India.

energy accumulator. Peak Power Tracking algorithms provide the theoretical means to achieve the MPP of solar panels, these algorithms can be realized in very effective manner. In the last few years, several MPPT techniques have been technologically advanced to maintain the PV arrays operating at their MPPs and have been suggested various examples such as the Perturb and Observe (P&O) method, the Incremental Conductance (IC) method, the Artificial Neural Network method, the Fuzzy Logic method [3-5], etc.... It became clear that perturb and observe (P&O) technique was widely used for its ease of implementation and tracking efficiency [6]. This paper present an adaptive perturb and observe MPPT for a photovoltaic module connected to the buck-boost converter (DC-DC converter). The DC-DC converter is able to draw maximum power from the PV module for a given solar radiation level and environment temperature by modifying the duty cycle of DC-DC converter. This paper offers the method to track the MPP for a PV module using Perturb & Observe (P&O) and Particle Swarm Optimization Algorithm (PSO) technique at varying irradiation and temperature. The PSO is a swarm intelligence-based algorithm used to find the global optimum solutions. The reasons why PSO has added the popularity is because it has only a very few parameters that need to be modified. Although PSO is still in its early stages, it has been used across a wide range of applications. On the other hand P&O method has simple structure and high reliability. The assumed techniques find the optimal electrical operating points and corresponding duty cycle at which the maximum power can be transferred. The performance of the proposed MPPT methods is tested by simulation at different irradiation and temperature using MATLAB. Solar panel specifications are used for simulation. To focus the proposed system performance, irradiation and temperature variations were applied in steps. The results are analyzed and compared.

Generalised Block Diagram:-

A. System Design

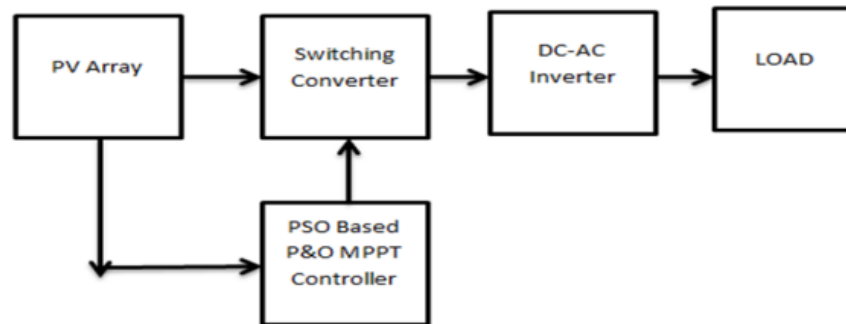

Fig.1:- System Design

The basic design for the photovoltaic system peak power tracker consists of the solar Panel, DC-DC converter (Buck- Boost) connected in a series, the MPPT controller, Voltage and current sensors and the load. This model is known to have better accuracy when the irradiance varies slowly that allows for a more accurate prediction of PV system performance. The Peak Power Tracker is a controlled DC/DC buck-boost converter used by a photovoltaic power system. The microprocessor tries to maximize the output power from the solar panel by controlling the conversion ratio of the DC/DC converter to keep the solar panel operating at its MPP [13]. A DC-DC converter acts as an interface between the load and the module. The Buck-Boost mode DC/DC converter is the most important type of switching regulator. In this converter, the buck and boost topologies are combined into one. The buck-boost converter steps the voltage down when the duty cycle is less than 50% and steps it up when the duty cycle is greater than 50%. The Peak Power Tracker uses an iterative approach to finding this constantly changing MPP [13].

Modelling of Solar Cell:-

In this study the five parameter model (The single diode model for solar cells figure 2) is a very proper choice. Firstly, because most times the results have a high degree of uniformity with data, secondly, as they are not too complex, it is relatively simple to implement and analyze them [7-8]. The equivalent circuit consists of a photocurrent, a diode, a parallel resistor expressing a leakage current, and a series resistor describing an internal resistance to the current flow, as shown in Figure 2.

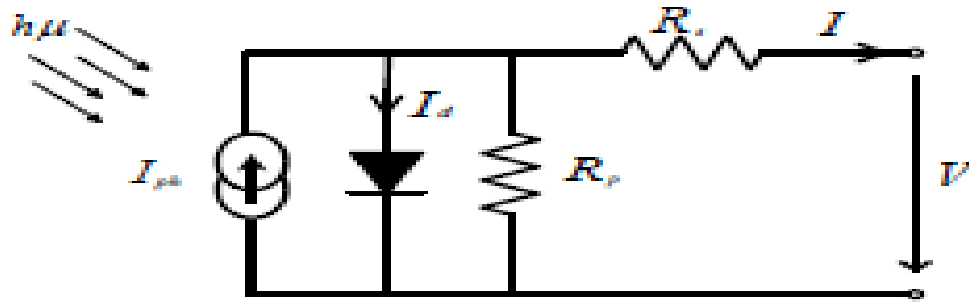

Fig. 2:- The equivalent circuit of practical PV cell.

The characteristic equation I-V is given by:

$$I = I_{ph} - I_o \left[\exp\left(\frac{V+IR_s}{AV}\right) - 1 \right] - \frac{V+IR_s}{R_p} \quad (1)$$

Where,

I_{ph} : Photo generated current.

I_o : Saturation current of diode.

R_s : Cell series resistance.

R_p : Cell parallel resistance.

A : Diode quality factor.

V : Thermal voltage.

Here, the PV model parameters; I_{ph} , I_o , R_s and R_p are determined based on electrical parameters; I_{sc} , I_{mp} , V_{mp} , V_{oc} and A . The aim is to find the model parameters such that the resulted I-V curve accurately matches the experimental curve. These parameters are obtained by solving the fundamental equation (1) for the key points. The values for I_{ph} , I_o , R_s and R_p are then determined through an iterative procedure [9-10].

Characteristics of Solar Cell:-

Several Cells are connected in series forms a PV panel/module whereas several PV modules are linked together to form PV arrays. If panels are in series current through the cell is constant and voltage across it increases while on the other hand when panels are in parallel current through the cell increases and voltage remains constant.

The I-V and P-V curve of a module is shown in the Fig. For a certain value of voltage and current the panel provides a maximum output. The output power of the panel increases as the module voltage increases, it reaches to a peak (called as peak power or maximum power point (MPP) in the module) and drops as the voltage approaches to the open circuit voltage. The peak power or MPP is defined at standard test condition (STC) of irradiation of 1000 W/m² and 25 0C module temperature, but these condition does not exist for the most of the time, due to which, normally, the module output power will be less than the peak output power.

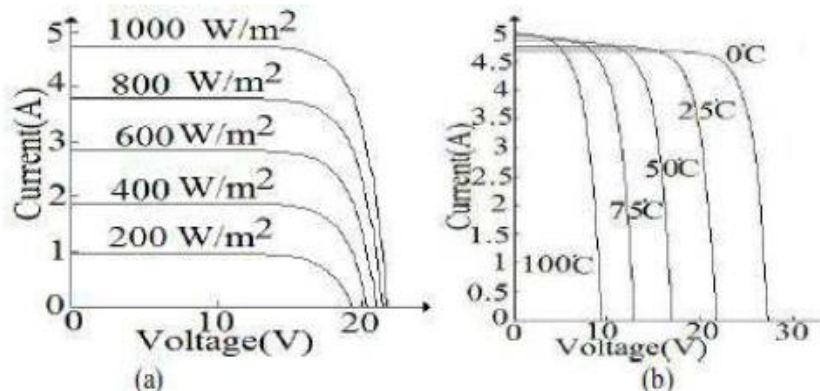

Fig.3:- Waveforms showing the effect of (a) Radiation and (b) Temperature on I-V characteristics

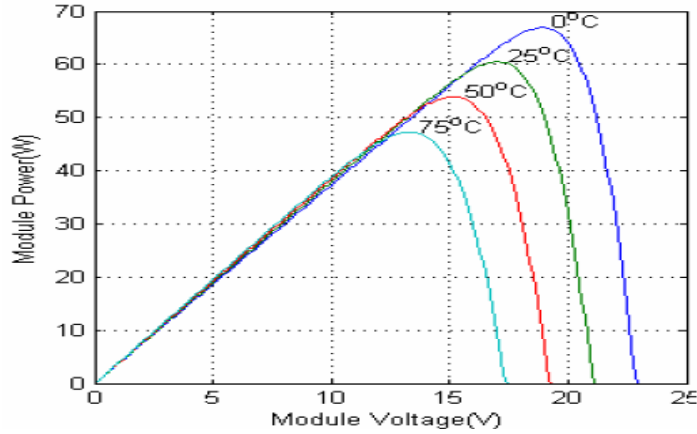

Fig.4:- PV curves at various temperatures and Constant irradiation.

In addition to this, the output current and the voltage are affected by the variations in the irradiation and temperature. Fig.4 and Fig.5 shows the waveforms for the effect of irradiation and temperature on I-V characteristics of a solar cell.

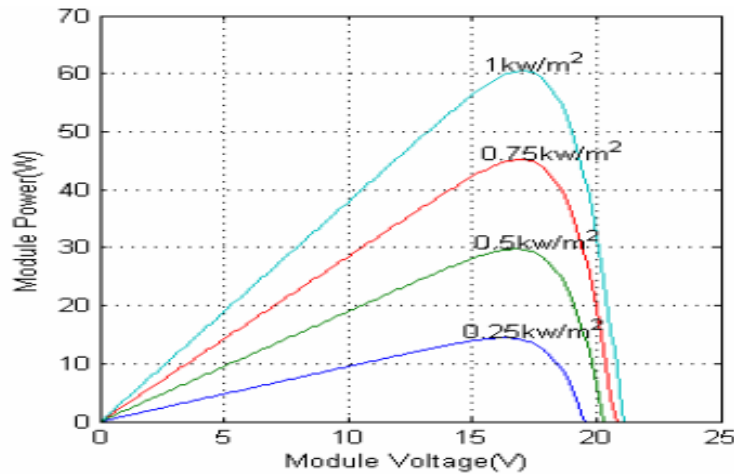

Fig.5:- PV curves at various irradiation levels and constant temperature

Under different conditions, there is a unique point on the curve, called the maximum power point (MPP), at which the photovoltaic cell operates with maximum efficiency and produces maximum output power.

MPPT Using Perturb and Observe Method (P&O):-

The perturb & observe (P&O) algorithm, also known as the “hill climbing” method, is very popular and the most commonly used in practice because of its simplicity in algorithm and the ease of implementation. The concept behind the "perturb and observe" (P&O) method is to modify the operating voltage or current of the photovoltaic panel until you obtain maximum power from it. For example, if increasing the voltage to a panel increases the power output of the panel, the system continues increasing the operating voltage until the power output begins to decrease. Once this happen, the voltage is decreased to get back towards the maximum power point.

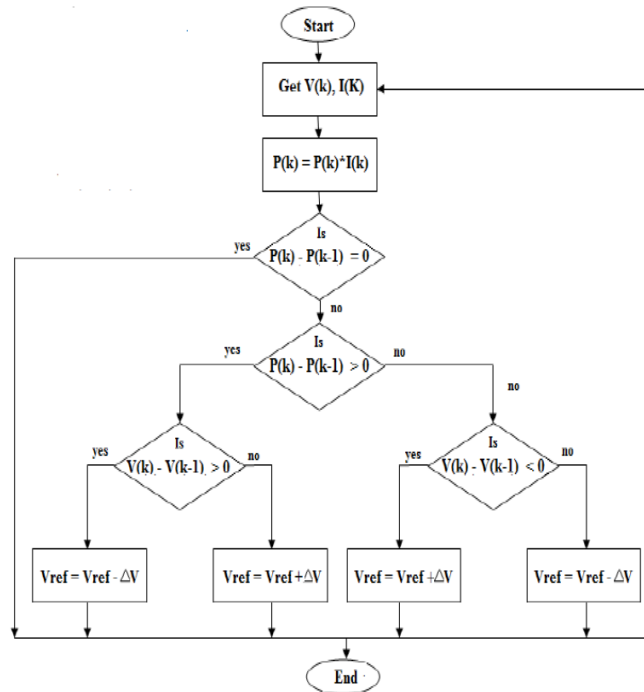

Fig.6:-Flow Chart for P&O MPPT Technique.

This perturbation continues indefinitely. Thus, the output power oscillates around a maximum power point and never stabilizes. The P&O technique has been widely used due to the simple feedback structure, reduced number of parameters and thus can be implemented quickly. In this algorithm the array terminal voltage and current were sensed and processed and power output is calculated. The present PV output power is compared with the power of previous perturbation cycle as shown in the flow chart. The PV voltage and current is perturbed periodically after comparing. If the PV operating voltage varies and change of power is greater than zero $dP/dV > 0$, the algorithm moves the operating point in the same direction, and if the change of power is less than zero $dP/dV < 0$, the algorithm moves the operating point in the opposite direction and if the change of power is equal to zero $dP/dV = 0$ that represents the condition of maximum power point.

The advantages of P&O algorithm is previous knowledge of the PV array characteristics is not required and its simple procedure. But the oscillation of the operating point around MPP under steady state conditions and inability to respond for the rapid changing atmospheric conditions are the drawbacks of this system.

Particle Swarm Optimization Application to MPPT Control:-

Particle Swarm optimization is an optimization method that tries to improve the particle solution with respect to given measure of quality. These particles moves around the search space according to position and velocity. Each particle is influenced by its own best position and velocity.

In PSO, particles are randomly initialized at different positions followed by position update based on new velocity, previous best positions and distance to Pbest to Gbest. Search process is continued till optimum value is obtained. As the particles, approach to MPP they get closer to Gbest position. Correspondingly, Pbest factor and Gbest factor in velocity term moves towards zero.

Eventually, zero velocity is obtained and duty cycle remains almost unchanged under this condition PV system reaches MPP. PSO is useful to track MPP in partial shading conditions. PSO can be used in conjunction with P&O MPPT technique to improve the tracking efficiency. PSO method;

- 1) Used to find out optimal duty cycle
- 2) PSO search starts with random initial guess and it is possible to explore the search region with continuous updation of duty cycle.

- 3) Reduction in steady state oscillations around MPP.
- 4) PSO alongwith MPPT technique responsible for direct duty cycle control.

Main feature is that absence of steady state oscillations at MPP and ability to track MPP for extreme environmental conditions i.e. effective in locating MPP. Drawback is its initial duty cycle selection. If duty cycle values are not within well defined limits and algorithm takes more no. of iterations to obtain the global maximum. This causes reduction in power output. Therefore it is necessary to specify limits of initial duty cycle.

A) Algorithm for PSO Implementation:

Step 1- Set the number of particles and searching parameters along with the limit for position and velocity

Step 2- Randomly initialize Position and velocity of each particle.

Step 3- Compute the fitness value of each particle.

Step 4- The particle having the best fitness value is set as Gbest (Global Best).

Step 5- Update the position and velocity of each particle with respect to the Gbest.

Step 6- Repeat Step 3 & 4 till the optimum solution is reached.

Step 7- Gbest at the end of the last iteration gives the optimized value.

Step 8- Compute the Duty-cycle using the given formula.

$$D = \frac{1}{1 + \sqrt{\frac{R_{in}}{R_{out}}}}$$

DC-DC Converters:-

They are power electronic circuits that converts a dc voltage to a different voltage level. Generally switched mode DC-DC converters are used i.e. the use of a switch or switches for the purpose of power conversion can be regarded as an SMPS. In order to perform power conversion with highest possible efficiency. Converter switches can be implemented using power BJT, power MOSFET, GTO thyristor, IGBT. There are different types of DC-DC converters such as Buck, Boost, Buck-Boost, Cuk converters etc.

One of the basic switched mode converter is the buck-boost converter. The output of the buck-boost converter can be either higher or lower than the input voltage. Assumption made about the operation of this circuit are;

Analysis of the boost converter begins by making these assumptions:-

- 5) The circuit is operating in the steady state.
- 6) The inductor current is continuous (always positive).
- 7) The capacitor is very large, and the output voltage is held constant at voltage V_o .
- 8) This restriction will be relaxed later to show the effects of finite capacitance.
- 9) The switching period is T , the switch is closed for time DT and open for time $(1-D)T$, The components are ideal.

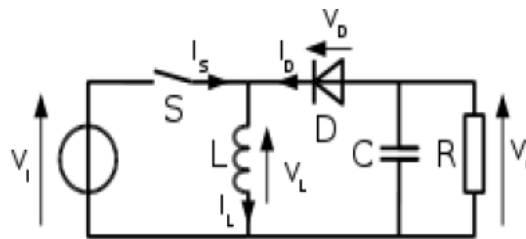

Fig.7:- Schematic of a buck–boost converter

The two operating states of a buck–boost converter: When the switch is turned-on, the input voltage source supplies current to the inductor, and the capacitor supplies current to the resistor (output load).When the switch is opened, the inductor supplies current to the load via the diode D.

Conclusion:-

The aim of this work is to propose a design of PV system peak power tracker and to realize a simple digital controller capable of optimizing the amount of power recovered from a solar panel over a range of environmental conditions. The basic design of the peak power tracker is to read the voltage and current levels at the solar panel simulator output, process these values using the P&O algorithm, and then adjust the voltage in order to obtain

maximum power. The results can be obtained and compared with theoretical operation which confirm the effectiveness of peak power tracking technique. Simulation of Maximum Power Point Tracking of a Solar PV panel using Particle Swarm Optimization and Perturbation & Observation techniques is responsible for direct duty cycle control. If Comparison of SPV panel output with and without optimization is carried out then the results show that particle swarm optimization technique given better results. Hence PSO technique can be employed for MPPT of Solar PV panels. This system is not only able to track MPP for extreme environmental conditions but also it reduces steady state oscillations at MPP which results in stability of the system.

References:-

1. Kim et al. New Maximum Power Point Tracker Using Sliding-Mode Observer for Estimation of Solar Array Current in the Grid-Connected Photovoltaic System. *Ieee Transactions On Industrial Elec- Tronics* 53 (2006) 1027-1035
2. Yinqing Zoua, Youling Yua, Yu Zhangb, Jicheng Lu, "MPPT Control for PV Generation System Based on an Improved Inccond Algorithm", *Procedia Engineering* 29,105 – 109, 2012.
3. V.Salas,E.Olias,A.Barrado,A.Lazaro, "Review of the maximum power point tracking algorithms for stand-alone photovoltaic systems", *Solar Energy Materials & Solar Cells* 90,1555–1578,2006.
4. A Bidyadhar Subudhi and Raseswari Pradhan "Comparative Study on Maximum Power Point Tracking Techniques for Photovoltaic Power Systems", *IEEE Transactions On Sustainable Energy* 1949-3029,2012.
5. Yong Yanga, FangPing Zhaob,"Adaptive perturb and observe MPPT technique for Grid connected Photovoltaic Inverters",*International Conference on Power Electronic and Engineering Application,Procedia Engineering* 23,468 – 473, 2011.
6. JancarleL.Santos,FernandoAntunes,et all,"A maximum power point tracker for PV systems using a high performance boost converter",*Solar Energy* 80,772–778, 2006.
7. Huan-Liang Tsai, Ci-Siang Tu, and Yi-Jie Su, "Development of Generalized Photovoltaic Model Using MATLAB/SIMULINK", *Proceedings of the World Congress on Engineering and Computer Science, WCECS,Oct 22-24,2008.*
8. N. Kahoul et al, Assessing the early degradation of photovoltaic modules performance in the Saharan region, *Energy Conversion and Management* 82 (2013) 320– 326.
9. Carrero, J. Rodriguez, D. Ramirez,C. Platero, "Simple estimation of PV modules loss resistances for low error modelling", *Renewable Energy* 35,1103–1108,2010.
10. Georgi Hristov Yordanov, Ole-Morten Midtgård, Tor Oskar Saetre,"Series resistance determination and further
11. Jaen C., Moyano C., Santacruz X., Pou J. and Arias A., 2008. Overview of maximum power point tracking control techniques used in photovoltaic systems. In *15th IEEE International Conference on Electronic Circuits and Systems*, Terrassa, 31 August – 4 September.
12. A. Nafeh, F. H. Fahmy, O. A. Mahgoub, and E. M. El-Zahab, "Developed algorithm of maximum power tracking for stand-alone photovoltaic system," *Energy Sources*, vol. 20, pp. 45–53, Jan. 1998.
13. Scheurer et al. Photovoltaic MPPT Charge Controller. Mentor Alan Shaffer Lakeland Electric, Sponsored by Workforce Central Florida, Spring 2012.