



ISSN NO. 2320-5407

Journal homepage: <http://www.journalijar.com>

INTERNATIONAL JOURNAL
OF ADVANCED RESEARCH

RESEARCH ARTICLE

Effectiveness of DVR to Compensate the Load Voltage Harmonics in Distribution Networks under Various Operating Conditions (using FOC induction motor as load)

Alok Jain, SumanBhullar

Electrical & Instrumentation Engineering Department, Thapar University, Patiala, India.

Manuscript Info

Abstract

Manuscript History:

Received: 13 August 2013

Final Accepted: 24 August 2013

Published Online: September 2013

Key words:

DVR, power quality,
VSC, Load Compensation,
THD.

Power quality has been an issue that is becoming increasingly pivotal in modern industrial and commercial applications. Voltage disturbances especially the voltage sag and swell are the most common power quality problems due to increased use of a large numbers of sophisticated and sensitive electronic equipment in industrial systems. To overcome this problem, custom power devices are used. One of the devices is the Dynamic Voltage Restorer (DVR), which is the most efficient and effective modern custom power device used in power distribution networks. It is a series connected power electronic based device that can quickly mitigate the voltage sags in the system and restore the load voltage to the pre-fault value. The primary advantage of the DVR is keeping the users always on-line with high quality constant voltage maintaining the continuity of production.

In this paper, a PI controller and a fuzzy logic controller method for DVR that protects a sensitive load, to counter voltage sag under unbalanced loading condition is presented. DVR along with other parts of the distribution system are simulated using MATLAB/ SIMULINK.

Copy Right, IJAR, 2013.. All rights reserved.

Introduction

Power quality and reliability in distribution systems have been attracting an increasing interest in modern times and have become an area of concern for modern industrial and commercial applications. Introduction of sophisticated manufacturing systems, industrial drives, precision electronic equipments in modern times demand greater quality and reliability of power supply in distribution networks than ever before. Power quality problems encompass a wide range of phenomena. Voltage sag/swell, flicker, harmonics distortion, impulse transients and interruptions are a prominent few. These disturbances are responsible for problems ranging from malfunctions or errors to plant shut down and loss of manufacturing capability. Voltage sags/swells can occur more frequently than any other power quality phenomenon. These sags/swells are the most important power quality problems in the power distribution system.

Voltage Sag or Voltage Dip is defined by the IEEE 1159 as the decrease in the rms voltage level to 10%-90% of nominal, at the power frequency for durations of ½ cycle to one minute.

Voltage Swell is defined by IEEE 1159 as the increase in the rms voltage level to 110%-180% of nominal, at the power frequency for durations of ½ cycle to one minute. The severity of a voltage swell is a function of the fault location, system impedance and grounding.

As the quality of power is strictly related to the economic consequences associated with the equipment and should therefore be evaluated considering the customers point of view. So the need for solutions dedicated to single customers with highly sensitive loads is great since a fast response of voltage regulation is required. Further it needs to synthesize the characteristics of voltage sags/swells both in domestic and industrial distributions. Alongside the variation in magnitudes, voltage sags/swells can also be accompanied by a change in phase angle. This phenomenon is known as phase angle jump (i.e. the variation of phase angle before

the onset and during the voltage sag/swell events and is calculated as an argument of the complex voltage).

In order to meet these challenges, it needs a device capable of injecting minimum energy so as to regulate load voltage at its predetermined value.

Dynamic Voltage Restorer (DVR) is one of the prominent methods for compensating the power quality problems associated with voltage sags/swells. Dynamic voltage restorer (DVR) can provide an effective solution to mitigate voltage sag/swell by establishing the appropriate predetermined voltage level required by the loads. It is recently being used as the active solution for voltage sag/swell mitigation in modern industrial applications.

In this paper, a new configuration of Dynamic Voltage Restorer (DVR) with PI controller and fuzzy logic controller is used which is capable of compensating power quality problems associated with voltage sags/swells and maintaining a prescribed level of supply voltage at the different load terminals. The simulation of the proposed DVR is accomplished using MATLAB/ SIMULINK. Here, the performance of the proposed DVR for different supply disturbances is tested under various operating conditions.

I. DYNAMIC VOLTAGE RESTORER (DVR)

It is also known as a static voltage booster (SVB) or a static series compensator (SSC). It is generally installed in distribution systems. It is a series custom power device intended to protect the sensitive loads at the point of common coupling (PCC) from various power quality problems.

DVR has the capability to deal with line voltage harmonics, reduction of transients in voltage, fault current limitations, voltage sags and voltage swells. Problems facing industries regarding the power quality are mainly voltage sags and swells. This may occur in developing countries where the grid quality is unsatisfactory. These problems can cause the sensitive equipment to fail or shutdown as well as create a large current imbalance that could blow up the fuses or trip the breakers. These effects can be very expensive for the customers, ranging from minor quality variations to production downtime and equipment damage. Use of DVR to mitigate voltage sags voltage swells is considered to be the most cost efficient method.

DVR works independently of the type of fault or any event. For practical cases, a more economical design can be achieved by only compensating the positive and negative sequence components of the voltage disturbance seen at the input of the DVR. Step down transformer offers infinite impedance for the zero sequence part of the

disturbance. The DVR supplies the active power with help of DC energy storage and required reactive power is generated internally. The injected active power should be minimized.

II. CONFIGURATION OF DVR

The configuration of a DVR consists of:

1. Injection/Booster/Isolation transformer
2. Harmonic/Passive filter
3. Storage devices/Energy storage systems
4. Voltage source converter/inverter
5. DC charging set
6. Control and Protection system

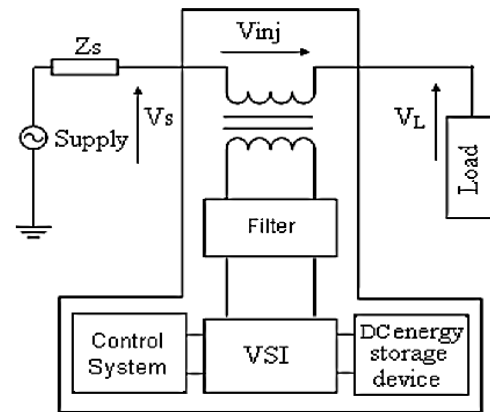

Figure1: Schematic representation of a DVR

1. Injection Transformer

It consists of a three phase transformer or three single phase transformers which limit the coupling of noise and transient energy from primary side to the secondary side. It connects the DVR to the distribution network via high voltage windings. Transformer can be connected in star/star configuration or delta/star configuration. If the system is connected in star/star configuration then zero sequence voltage compensation is required. If a delta/star configuration is used then no zero sequence voltage compensation is required as it offers infinite impedance for zero sequence components.

It isolates the load from rest of the system and couples the injected voltages generated by the voltage source converter to the incoming supply voltage. The transformer winding ratio is determined according to the voltage requirement in its secondary side. Usually, winding ratio is kept equal to the supply voltage so as to allow the DVR to provide full voltage sag compensation. The rating of the transformer is an important factor to determine the performance of a DVR as it limits the maximum compensation ability of the DVR.

2. Harmonic/Passive filter

Usually, a filter unit consists of inductor and capacitor. It eliminates the unwanted harmonic components produced by the voltage source converter.

3. Storage devices/Energy storage systems

They fulfil the active requirements of the load. Various systems can be used for this purpose like flywheel, super conducting magnetic energy storage systems (SMES), lead acid batteries.

4. Voltage source converter/inverter

It basically consists of a storage device and switching devices. It produces sinusoidal voltage of desired phase angle and magnitude. There are four main types of storage devices: MOSFET, GTO, IGBT and IGCT. Highly sophisticated converter design with IGBT's are used which allows the DVR to compensate large voltage dips.

5. DC charging set

It performs two main tasks which are as follows:

- * It charges the dc source after a sag compensation event.
- * It maintains dc link voltage at the nominal dc link voltage.

Excess of dc link voltage will damage the dc storage capacitor and switching device.

6. Control and Protection system

As there exists different operating modes of DVR so all protective functions of DVR are implemented in combination of hardware and programmable logic control. The control system determines the voltage that should be injected by the DVR. Transformer can be provided with differential current protection.

III. OPERATION OF A DVR

It injects dynamically controlled voltages in series with the bus voltage through the booster transformer. The amplitudes of the injected phase voltages are controlled so as to eliminate the detrimental effects of a bus fault to the load voltage.

The system impedance Z_{th} depends on the fault level of the load bus. When the system voltage (V_{th}) drops, the DVR injects a series voltage V_{DVR} through the injection transformer so that the desired load voltage magnitude V_L can be maintained. The series injected voltage of the DVR can be written as:

$$V_{DVR} = V_L + Z_{th} I_L - V_{th}$$

$$I_L = \left(\frac{P_L + jQ_L}{V_L} \right)$$

Where,

V_L = Desired load voltage magnitude

Z_{th} = load impedance

I_L = Load current

V_{th} = system voltage during fault condition

IV. OPERATING MODES OF A DVR

Different operating modes of DVR are as follows:

Protection mode:

If the over current on the load side exceeds a permissible limit due to short circuit on the load or large inrush current, the DVR will be isolated from the system by using the bypass switches (S2 and S3 will open) and supplying another path for current (S1 will be closed).

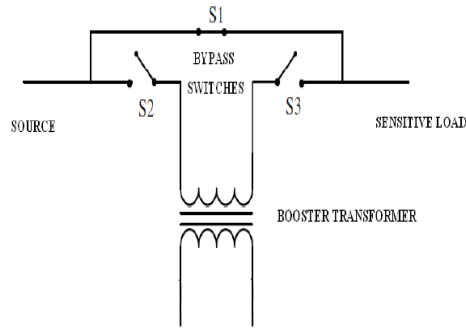

Figure2: Protection mode of a DVR

Injection/Boost Mode:

In this mode, $V_{DVR} > 0$. In the Injection/Boost mode, the DVR is injecting a compensating voltage through the booster transformer due to the detection of a disturbance in the supply voltage.

Standby Mode:

In this mode, $V_{DVR} = 0$. The booster transformers low voltage winding is shorted through the converter. No switching of semiconductors occurs in this mode of operation and the full load current will pass through the primary. Losses of the DVR during this mode should be minimised.

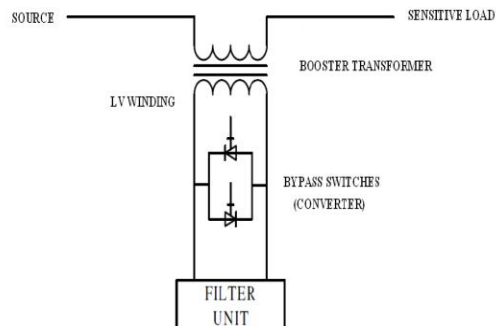

Figure3: Standby mode of a DVR

V. CONTROL SCHEME

i. PI CONTROLLER-DISCRETE PWM BASED CONTROL SCHEME:

In order to mitigate the simulated voltage sags in the test system of each compensation technique, also to compensate voltage sags in practical application, a discrete PWM-based control scheme is implemented, with reference to DVR.

Voltage sag is created at load terminals by a SLG (Single line to Ground) fault as shown in figure5. Load voltage is sensed and passed through a sequence analyzer. The magnitude is compared with reference voltage (V_{ref}). Pulse width modulated (PWM) control technique is applied for inverter switching so as to produce a three phase 50Hz sinusoidal voltage at the load terminals. Chopping frequency is in the range of a few KHz. The IGBT inverter is controlled with PI controller in order to maintain 1 p.u. voltage at the load terminals i.e. considered as base voltage =1p.u.

A proportional-integral (PI) controller shown in figure4 drives the plant to be controlled with a weighted sum of the error (difference between the actual sensed output and desired set-point) and the integral of that value. An advantage of a proportional plus integral controller is that its integral term causes the steady-state error to be zero for a step input. PI controller input is an actuating signal which is the difference between the V_{ref} and V_{in} . Output of the controller block is of the form of an angle δ , which introduces additional phase-lag/lead in the three-phase voltages.

The output of error detector is $V_{ref} - V_{in}$.
 V_{ref} equal to 1 p.u. voltage.
 V_{in} voltage in p.u. at the load terminals.

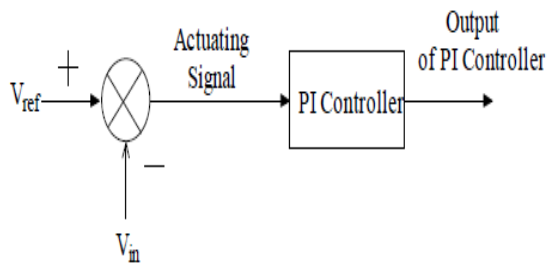

Figure4: Schematic of a typical PI Controller

The controller output when compared at PWM signal generator results in the desired firing sequence. The sinusoidal voltage $V_{control}$ is phase-modulated by means of the angle δ or delta and the modulated three-phase voltages are given by-

$$V_A = \sin(\omega t + \delta)$$

$$V_B = \sin(\omega t + \delta - 2\pi/3)$$

$$V_C = \sin(\omega t + \delta + 2\pi/3)$$

The modulated angle is applied to the PWM generators in phase A. The angles for phases B and C are shifted by 120° and 240°. In this PI controller, only voltage magnitude is taken as a feedback parameter in the control scheme.

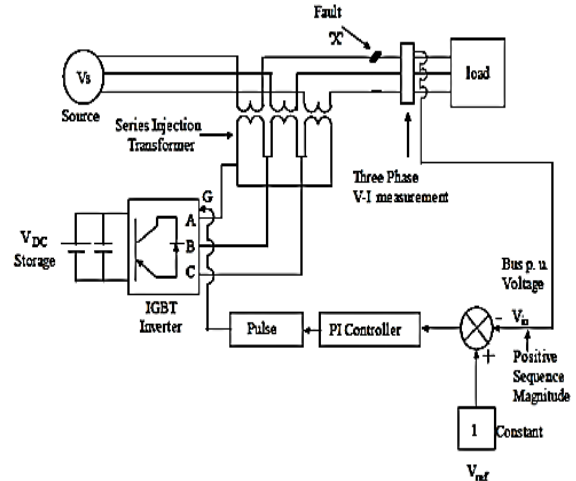

Figure5: Circuit Model of DVR Test System

ii. FUZZY LOGIC CONTROLLER

In fuzzy logic, basic control is determined by a set of linguistic rules which are determined by the system. Since numerical variables are converted into linguistic variables, mathematical modelling of the system is not required. The fuzzy logic control is being proposed for controlling the inverter action. The fuzzy logic controller has two real time inputs measured at every sample time, named error and error rate and one output named actuating signal for each phase. The input signals are fuzzified and represented in fuzzy set notations as membership functions.

The defined ‘If ... Then ...’ rules produce output (actuating) signal and these signals are defuzzified to analog control signals for comparing with a carrier signal to control PWM inverter.

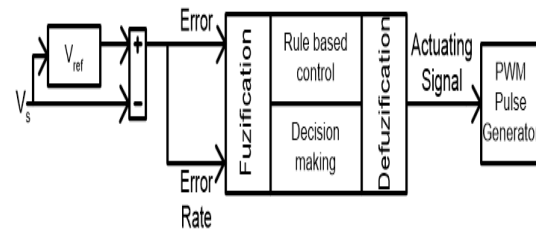

Figure6: Block diagram of proposed control system

• Input Parameters

Two variables, error in voltage i.e. difference between supply voltage and the reference voltage and error rate i.e. the rate of change of error of voltage are taken as input to fuzzy logic controller. Error and error rate are defined as:

$$\text{Error} = V_{\text{ref}} - V_s$$

$$\text{Error rate} = \text{error}(n) - \text{error}(n-1)$$

• Fuzzification

In this simulation study, the error and error rate are defined by linguistic variables such as negative big (NB), negative medium (NM), negative small (NS), zero (ZE), positive small (PS), positive medium (PM) and positive big (PB) characterized by triangular membership functions. These functions have been chosen to satisfy the output needs of the fuzzy controller. The output is also defined by seven linguistic variables such as negative big (NB), negative medium (NM), negative small (NS), zero (ZE), positive small (PS), positive medium (PM) and positive big (PB) characterized by membership functions given in figure7.

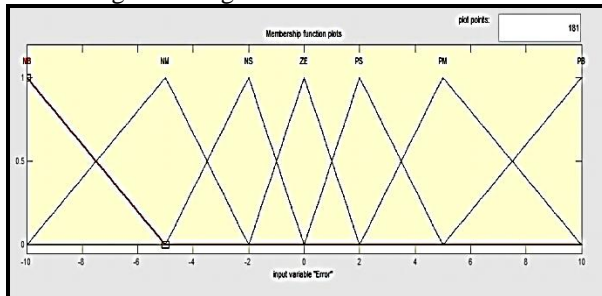

Input Variable 'Error'

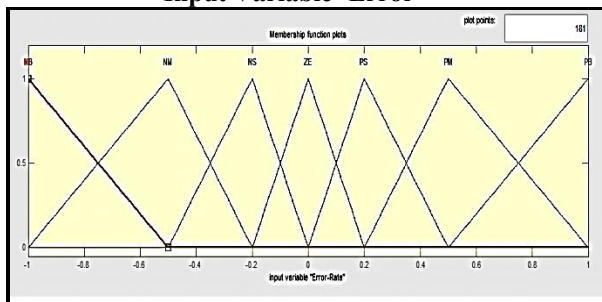

Input Variable 'Error Rate'

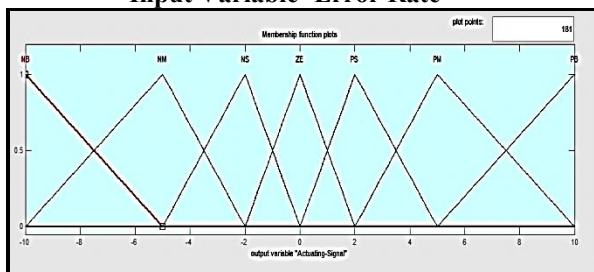

Output Variable 'Actuating Signal'

Figure7: Membership Functions for inputs and output

• Decision Making

Fuzzy process is realized by Mamdani method. Mamdani inference method has been used because it can easily obtain the relationship between its inputs and output. The set of rules for fuzzy controller are represented in Table 1. There are 49 rules for fuzzy controller. The output membership function for each rule is given by the Min (minimum) operator.

The Max operator is used to get the combined fuzzy output from the set of outputs of Min operator. The output is produced by the fuzzy sets and fuzzy logic operations by evaluating all the rules.

A simple if-then rule is defined as follows:
If error is Z and error rate is Z then output is Z.

Table1: Fuzzy rules

Ce/e	NB	NM	NS	Z	PS	PM	PB
NB	NB	NB	NB	NM	NM	NS	Z
NM	NB	NB	NM	NM	NS	Z	PS
NS	NB	NM	NM	NS	Z	PS	PM
Z	NM	NM	NS	Z	PS	PM	PM
PS	NM	NS	Z	PS	PM	PM	PB
PM	NS	Z	PS	PM	PM	PB	PB
PB	Z	PS	PM	PM	PB	PB	PB

• Defuzzification

It is the process of converting the controller outputs in linguistic labels represented by fuzzy set to real control (analog) signals. Centroid method is used for defuzzification in this paper.

• Signal Processing

The outputs of FLC process are the control signals that are used in generation of switching signals of the PWM inverter by comparing with a carrier signal.

VI. PARAMETERS OF DVR TEST SYSTEM

Electrical circuit model of DVR test system is shown in figure5. System parameters are listed in Table 2. Voltage sag is created at load terminals via SLG fault as shown in figure5. Load voltage is sensed and passes through a sequence analyser. The magnitude is compared with V_{ref} .

MATLAB/Simulation diagram of the test system for DVR is shown in figure8. System comprises of 11 kV, 50 Hz generator, feeding transmission lines through a three-phase, three-winding transformer connected in $\Delta/Y/Y$, 11000/400/400V.

In this test system, two similar loads with different feeders are considered. One of the feeders is connected to DVR and the other is kept as it is. This test system is analyzed under SLG fault condition.

VII. SIMULATION MODELS OF THE TEST SYSTEM WITH INDUCTION MOTOR AS LOAD

In this SIMULINK model, systems with two parallel feeders are shown. In both the feeders further

similar loads are connected. In one feeder DVR is connected in series with line and the other feeders is kept as it is.

Table2: System Parameters

Serial number	System Quantities	Parameters
1.	Source	3 phase, 11kV rms (phase-phase), 50Hz, 500e ⁶ Short circuit level(VA), 11kV Base voltage, $\frac{X}{R} = 0.5$.
2.	Convertor	IGBT based, 3 arms, 6 pulse, $R_{on} = 1e^{-3}$ ohms
3.	Discrete 3-phase PLL	$K_p = 20, K_i = 50$, sampling time 50 μ s
4.	Transformer	Nominal power 200e ³ VA, 50 Hz, $\Delta/Y/Y$ (grounded) 11000/400/400V, $(R_1/R_2/R_3, L_1/L_2/L_3) = (0.002/0.002/0.002, 0.08/0.08/0.08)$ p.u.
5.	FOC Induction Motor Drive	Stator Resistance ($14.85e^{-3}$), Rotor Resistance ($9.295e^{-3}$), Leakage Inductance ($0.3027e^{-3}$), Mutual Inductance ($10.46e^{-3}$), Nominal power 200e ³ VA, 400V rms (phase-phase), 50 Hz.

- **PI Controller** is used for the control purpose-

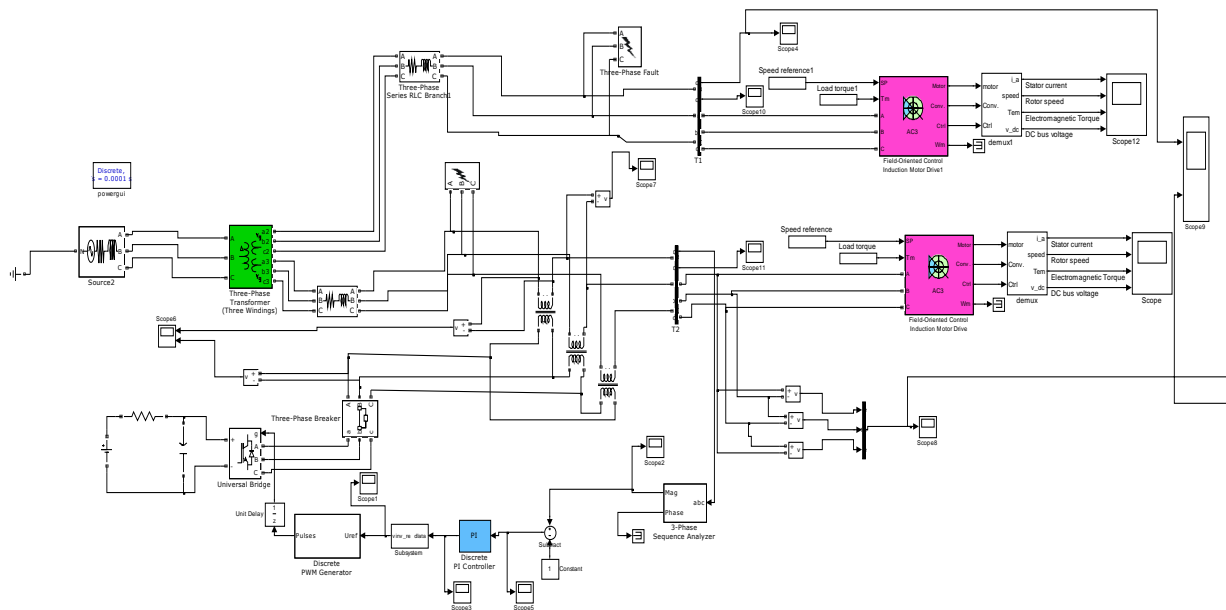

Figure8a: Simulation Model of DVR Test System

- **FUZZY LOGIC Controller** is used for the control purpose-

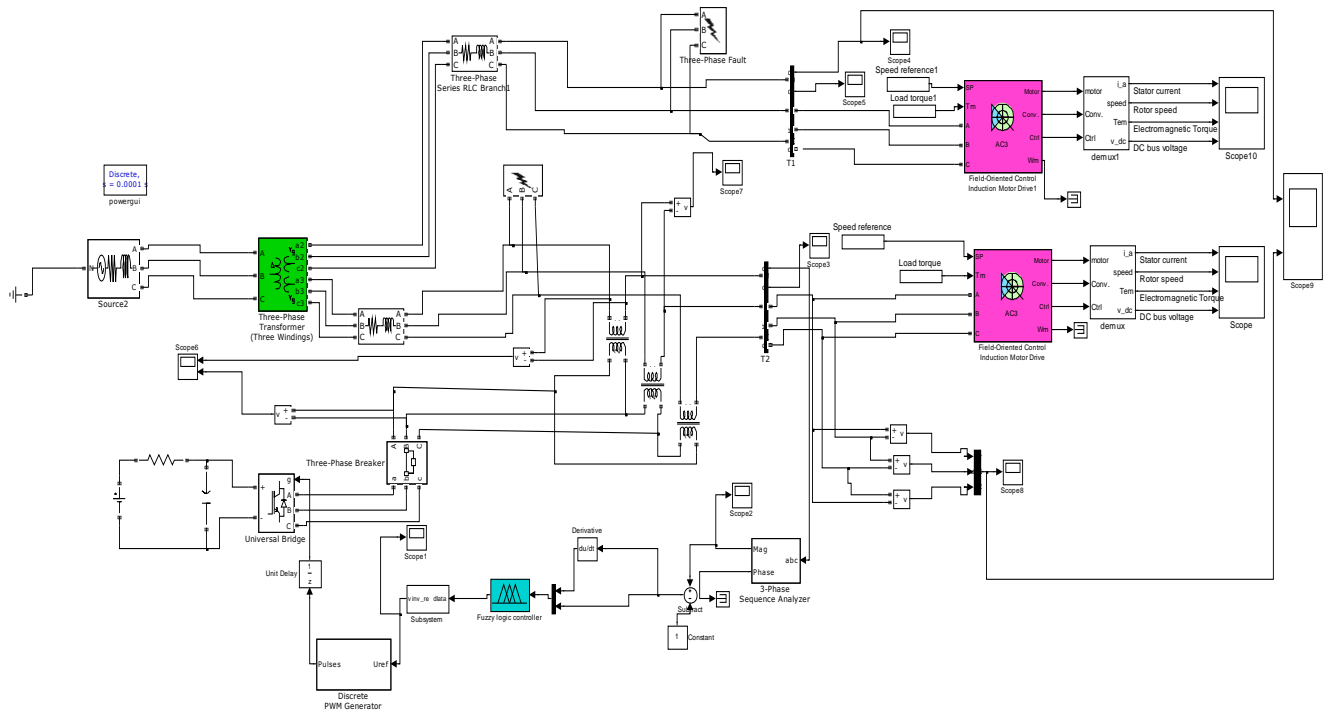

Figure8b: Simulation Model of DVR Test System

VIII. SIMULATION RESULTS

Here simulations are performed on the DVR test system using MATLAB/SIMULINK. The system performance is analysed for compensate the load voltage in distribution networks under SLG fault condition. FOC Induction Motor loadcondition is considered to study the impact of DVR in distribution system. Different cases are listed below:

Results for FOC Induction Motor Drive

SLG fault is considered for the test system delivering induction motor as load. Here the fault resistance is 0.001 ohm and the ground resistance is 0.001 ohm. The fault is created for the duration of 0.4s to 0.6s. The output waves for the load voltage without and with compensation are shown in Figure.9(a) & Figure.9(b) (With PI Controller); Figure.9(c) & Figure.9(d) (With Fuzzy Controller). Here it is clear from the output wave shapes that the voltage in the phase where fault is created is increasing during the fault duration in the uncompensated feeder. When DVR is connected in the system the unbalancing is reduced.

- **PI Controller** is used for the control purpose-

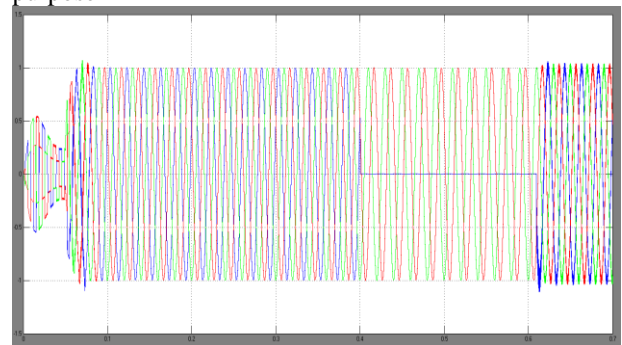

Figure9(a): Output load voltage of SLGFault without compensation

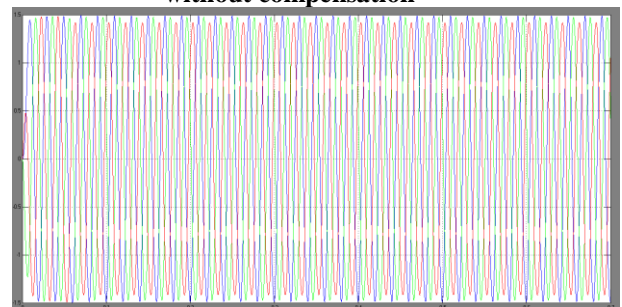

Figure9(b): Output load voltage of SLG Fault with compensation

- **Fuzzy Logic Controller** is used for the control purpose-

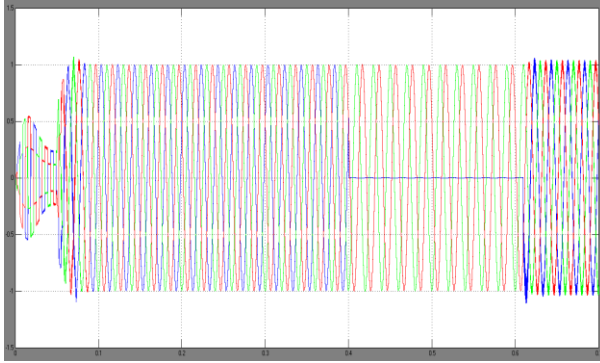

Figure9(c): Output load voltage of SLG Fault without compensation

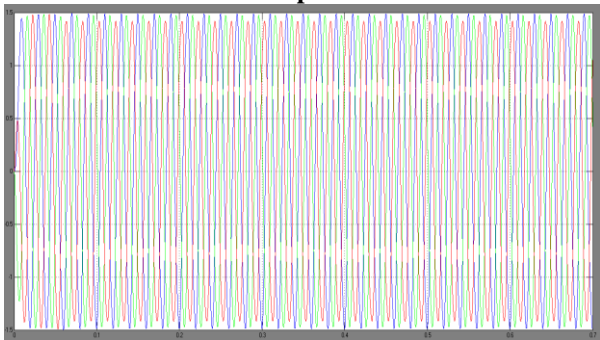

Figure9(d): Output load voltage of SLG Fault with compensation

IX. COMPARISON OF THD LEVELS FOR DIFFERENT TYPES OF LOADS

The Comparison of THD levels for different types of loads under SLG fault condition with or without DVR is shown in table 3. It is clear from the THD analysis that DVR effectively removes harmonics from load voltage and makes it smooth.

X. CONCLUSION

In this paper, DVR has been modeled and simulated in MATLAB environment. The performance of DVR has been analyzed for FOC induction motor drive. DVR has been found to regulate voltage under varying load condition and load unbalancing. It is clear from comparison of THD analysis for different types of loads under SLG fault condition that DVR reduces harmonics from load voltage very effectively and makes it smooth. Hence, it is concluded that DVR has a huge scope in improving power quality in distribution systems.

XI. REFERENCES

1. Woodley N.H., Senior Member, IEEE, Morgan L., Member, IEEE, Sundaram A., Member, IEEE, "Experience with an Inverter-Based Dynamic Voltage

- Restorer" *IEEE Transaction on Power delivery*, Vol. 14, No. 3, July 1999.
2. Chang C.S., Ho Y.S., "The Influence of Motor Loads on the Voltage Restoration Capability of the Dynamic Voltage Restorer" *PowerCon, International Conference*, Vol. 2, pp. 637-642, 2000.
3. Zhan Changjiang, Ramachandaramurthy Vigna, Arulampalam Aputharajah, Fitzer Chris, Kromlidis Stylianos, Barnes Mike, Jenkins Nicholas, "Dynamic Voltage Restorer Based on Voltage SVPWM Control" *IEEE Transactions on Industry Applications*, Vol. 37, No. 6, Nov-Dec. 2001.
4. Godsk Nielsen John., Blaabjerg Frede, "Control Strategies for Dynamic Voltage Restorer Compensating Voltage Sags with Phase Jump" *Applied Power Electronics Conference and Exposition, IEEE*, Vol. 2, pp. 1267-1273, 2001.
5. Jurado Francisco, Member, IEEE, Manuel Valverde, University of Jaen, "Fuzzy Logic Control of a Dynamic Voltage Restorer" *IEEE-ISIE*, Vol. 2, pp. 1047-1052, 2004.
6. Boonchiam Paisan, Mithulanathan Nadarajah, Rajamangala University of Technology, Thanyaburi, Thailand, "Detailed Analysis of Load Voltage Compensation for Dynamic Voltage Restorers" *TENCON, IEEE region 10 conference*, pp. 1-4, 2006.
7. Jowder Al. Fawzi, "Modeling and Simulation of Dynamic Voltage Restorer Based on Hysteresis Voltage Control" *33rd Annual Conference of the IEEE Industrial Electronics Society (IECON)*, Nov. 5-8, 2007, Taipei, Taiwan.
8. Kumar Ravi, Nagaraju Siva, J.N.T.U. College of Engineering, Kakinada, A.P, India, "Simulation of D-STATCOM and DVR in Power" *APRN Journal of Engineering and Applied Sciences*, ISSN 1819-6608, Vol. 2, No. 3, June 2007.
9. Ashari M., Hiyama T., Pujiantara M., Suryatmojo H., Purnomo M.H., "A Novel Dynamic Voltage Restorer with Outage Handling Capability Using Fuzzy Logic Controller" *Innovative Computing, Information and Control*, pp.51, 5-7 Sept. 2007.
10. Margo P., Heri P.M., Ashari M., Hendrik M., Hiyama T., "Compensation of Balanced and Unbalanced Voltage Sags using DVR Based on Fuzzy Polar Controller" *International Journal of Applied Engineering Research*, ISSN 0973-4562, Vol. 3, No. 3, pp. 879-890, 2008.

11. JayaPrakashP., Member, IEEE, Singh bhim, Senior Member, IEEE, Kothari D.P., Senior Member, IEEE, Chandra Ambrish, Senior Member, IEEE, Al-Haddad Kamal, Fellow, IEEE, "Control of Reduced Rating DVR with Battery ESS" *IEEE*, 2008.
12. ChellaliBenachaiba, BrahimFerd, "Voltage Quality Improvement Using DVR" *Electrical Power Quality and Utilisation*, Vol. 14, No. 1, pp. 39-46, 2008.
13. Pal Yash, Swarup A., Senior Member, IEEE, Singh Bhim, Senior Member, IEEE "A Review of Compensating Type Custom Power Devices for Power Quality Improvement" *IEEE Power India Conference*, pp. 1-8, 2008.

Table 3: THD levels of the test system

Sr. No.	System Conditions	PI CONTROLLER				FUZZY CONTROLLER			
		Without DVR		With DVR		Without DVR		With DVR	
		LOAD VOLTAGE (fundamental in p.u.)	THD (%)	LOAD VOLTAGE (fundamental in p.u.)	THD (%)	LOAD VOLTAGE (fundamental in p.u.)	THD (%)	LOAD VOLTAGE (fundamental in p.u.)	THD (%)
1.	FOC Induction Motor Drive								
	SLG fault	0.3903	11.50	1.481	5.85	0.3903	11.51	1.481	3.85

