



ISSN NO. 2320-5407

Journal homepage: <http://www.journalijar.com>

INTERNATIONAL JOURNAL
OF ADVANCED RESEARCH

RESEARCH ARTICLE

A minimalist analysis of morphosyntactic properties of Dholuo verbal extensions.

By Walter Ochieng Sande, Dr. Obiero Ogone and Dr. Ondondo Emily.

Department of Linguistics, Languages and Literature Jaramogi Oginga Odinga University of Science and Technology, Kenya.

Manuscript Info

Manuscript History:

Received: 14 December 2015
Final Accepted: 19 January 2016
Published Online: February 2016

Key words:

Checking, Movement, Apparatus,
Verbal matrix, Projection, Domain,
Head, Node.

*Corresponding Author

By Walter Ochieng Sande.

Abstract

This article explores the operation of Minimalist Program (MP) in the analysis of morphosyntactic structure of Dholuo verbal extensions. It examines how derivational features of five Dholuo verbal extensions namely, applicative, locative, reflexive, reciprocal and stative get interpreted through covert movement and checking of morphosyntactic features in derived Dholuo verbs. Some scholars argue that movement does not occur in Dholuo because of its weak morphology. It is against this argument that this article tends to make contribution to the applicability of the movement to Dholuo verb morphology using the five extensions thus proving further the universality of the MP in the analysis of languages.

Copy Right, IJAR, 2016.. All rights reserved.

Introduction:-

In the Minimalist Program (MP), structures are represented and generated to account for language phenomena using the smallest set of devices for the linguistic system to be as economical as possible (Chomsky, 1995). According to Chomsky's (2000, 2005) remarks, MP is not a theory but a set of guidelines that should ideally lead to a maximal projection of the theoretical apparatus used to describe and account for linguistic data. These apparatuses include the movement, the checking, the numeration, the greed and the merger each with its significant role in the analysis of linguistic data.

The MP considers a sentence to have a phrase structure comprising a lexical domain, a verb phrase (VP) and a functional domain. The lexicon is a set of lexical elements each with an articulated system of features (Chomsky, 1995). These features are word build-ups. The functional domain is the domain within which the functional features of a verbal structure such as person, gender, number, case and tense get checked for their correct interpretations. According to the MP, a sentence is a projection of the VP. The VP is therefore the point from which constituents of a construction move to have their features checked. For illustration consider example below from English.

Fred runs a shop.

The sentence in example above has a phrase structure with a lexical domain namely; the noun phrases (NPs), 'Fred' and 'a shop' which appear with lexical case markings. The verb 'run' gets its grammatical interpretation within the functional domain of tense (non-past) and agreement both of which are marked by the bound morpheme 's'.

It is from the VP domain that the items constituting a sentence as in example above move to their respective inflectional heads where their features get checked for correct grammatical interpretation. The VP in the sentence is made up of the internal argument (object) 'a shop' and the external argument 'Fred' operating as the subject of the verb 'run'. The verb 'run' in this sentence is responsible for assigning the two arguments their syntactic roles as the subject and the object.

The lexical items from the lexicon are typically projected via the Bare Phrase Structure to the interface-Logical Form (LF) and Phonological Form (PF). LF is the grammatical structure relevant to meaning while PF is relevant to sound. The LF and PF are the only points according to the MP where a linguistic expression is well represented. An English expression like the one in the example above is represented directly at LF without moving through the PF interface since English has weak phonological features which do not require phonological isolation in the interpretation of items in the sentence.

The syntactic structure of a sentence is represented as an ordered series of trees (Chomsky, 1993). The tree is composed of projections of heads selected from the lexicon. Constituents of a sentence or a phrase have heads on which other elements of the constituents are dependent for their grammatical interpretation. The syntactic structure also contains the specifier which nouns depend on for their case feature checking. These heads match the morphology of verbs. The morphology of verbs constitute morphological features; the subject agreement (AGRs), the object agreement (AGRo) and the tense (TNS) or the aspect (ASPE) agreements. The AGRs and AGRo project to subject agreement phrase (AGRsP) and object agreement phrase (AGRoP) respectively. These heads are reflected in the MP basic sentence structure shown in figure 1.

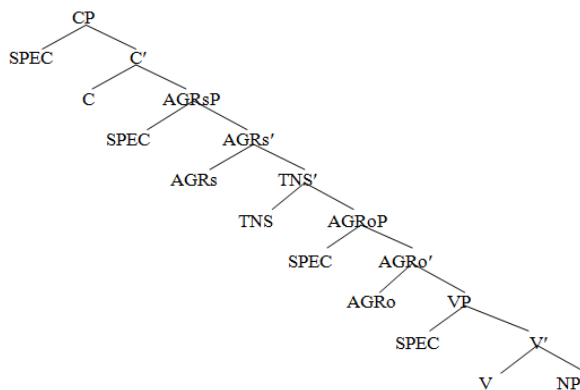

Figure 1: The Basic Minimalist Program Structure (Chomsky, 1993)

Items that constitute a sentence structure have got features. The number of heads and specifiers in a syntactic tree is feature driven. This means that Chomsky's basic sentence structure in figure (1) above is subject to alteration depending on the number of features to be checked. These features are lexical or morphological.

Schroeder (2008:34) points out that feature checking requires all languages to have verb movement, that is, all languages move their verbs to the inflectional nodes(heads) and NPs are moved to the specifier of AGRsP and AGRoP for feature checking. For instance, in the sentence in given above, the NP 'Fred' gets its nominative case feature checked at SPEC, a projection of the AGRsP. The verb 'run' gets its tense feature interpretation at the TNS head which projects from TNS'. For checking of agreement features in terms of number and person, the verb moves to the AGRs head for subject agreement feature checking. The accusative case feature checking of the NP 'a shop' takes place at the SPEC head transformed from AGRoP.

In figure in 1 above, AGRs and AGRo are heads containing functional features (gender, number and person), which distinguish the agreement-marking of the two functional roles of AGR, subject 'Fred' and object 'a shop'. Of note is that whenever these items move (covert movement), they leave their traces behind. The traces can be subject trace (ts), verb trace (tv) or object trace (to).

According to the greed principle of the MP, every item in a construction moves in order to satisfy its own lexical or functional feature. For example, the NPs 'Fred' and 'a shop' in the sentence given above move by themselves to satisfy their lexical features- the case features, nominative and accusative. The verb 'run' also moves for its own functional features satisfaction which are tense and agreement features.

This article focuses on an MP analysis of morphosyntactic structure Dholuo extended verbs. The article is organized into four sections as follows: section 2 gives looks at MP analysis of unextended Dholuo verbs. Section 3 focuses on the analysis of extended Dholuo verbs. Lastly, section 4 is a summary to the article.

Minimalist Analysis of Dholuo Unextended Verbs:-

A Dholuo verb in its base form constitutes a verb root, followed by the indicative suffix '-o'. These verbs are usually encapsulated in a verbal complex comprising a subject prefix (S) followed by a verb root after which comes the indicative suffix and an object suffix (O) in that order, as seen in example (1).

- 1) *a-many-o-gi*
 S-Root-IND-O
 I search for them

The Minimalist Program has got apparatuses also called principles. Every principle has got a specific role it takes in an analysis of a language using the MP. The choices of these principles depend on the structure of the language under analysis. According to Chomsky (1993) the bare phrase structure in MP allows for the projection to be built as per the language of analysis. Dholuo is an agglutinating language whose MP analysis can produce a partial tree which has no SPEC that is, with the free standing subject and/or object dropped. Consider example (2).

- 2) *i-her-ø-a*
 2sgS-love-IND-1sgO
 You love me.

In the construction in example (2) above, there are no overt subject and object noun phrases. These arguments are marked by affixes. The nominal features of person and number are attached to the verb to recover the content of the overt subject and object noun phrases.

In the MP analysis of the construction in (2) above, every item constituting the construction is given an inflectional head where the verb moves to have its morphological agreement features checked, as shown in figure 2.

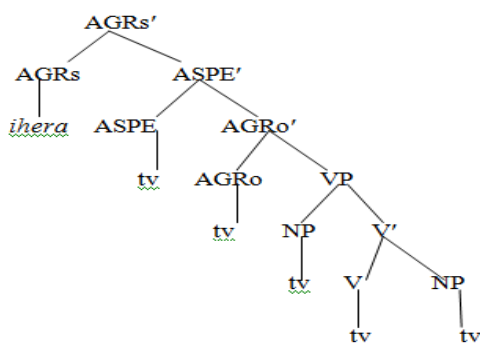

Figure 2: Syntactic Configuration of the Construction, 'ihera'

The verb in the construction in figure 2 above has both the subject and object arguments incorporated within its matrix. All the movements the verb makes to the inflectional heads are therefore for both subject and object agreement feature checking. For object agreement feature checking, the verb moves from V/V', a position inside VP to a position outside the VP, AGRo/AGRo'. Since the verb is also inflected for aspect, it makes its movement to ASPE/ASPE' head where the aspect feature is checked. The move of the verb ends at AGRs/AGRs' node where the verb is checked for the subject agreement feature. All these movements enhance the full interpretation of all the features that build up the construction.¹

¹ Of note is that all the checking in Dholuo verbs happen at LF (Logical Form) since the Full Interpretation (FI) of the lexical items constituting a construction does not need phonological distinctions at the point of interpretation.

Dholuo verbal constructions can occur as monotransitive, ditransitive or intransitive. Dholuo monotransitive verbs subcategorise for two arguments, the subject and the object arguments, as shown in example (3).

- 3) *a-goy-o-u*
 1sgS-beat-IND-2pIO
 We are beating you.

The verb in the example in (3) above subcategorizes for two arguments, the subject argument 'a' and the object argument 'u'. These arguments are allocated their own heads where their agreement features are checked, as shown in figure 3.

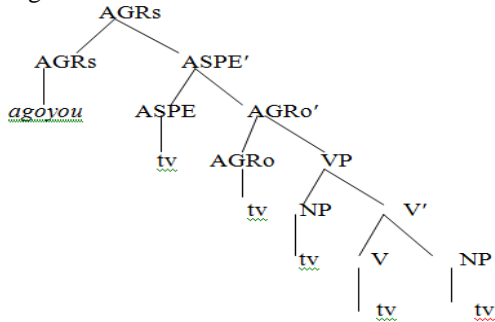

Figure 3: Syntactic Configuration of the Construction, 'agoyou'.

For feature checking, inflectional heads are created in the MP tree, as shown in figure 3 above. It is to these heads that the verb makes movements for inflectional feature checking. These features are checked for their correctness in the syntactic positions in the construction. The verb first makes its own movement from within the VP domain to AGRo/AGRo' node for object agreement feature checking. From there, it moves to ASPE/ASPE' head for progressive aspect feature checking. The movement ends at AGRs/AGRs' head where the subject agreement feature in the verb is checked.

Dholuo ditransitives subcategorises for two object arguments and one subject argument. Consider example (4).

- 4) *u-miy-φ-a_chiemo*
 2plS-give-IND-1sgO _food
 You are giving me food.

The verb in the construction in (4) above has two incorporated arguments: the subject argument 'u' and the indirect object argument 'o' on the other hand, and a free standing direct object argument 'chiemo' which is assigned a case by the verb. Every item in the verbal matrix consists of features to be checked for their interpretation, as shown in figure 4.

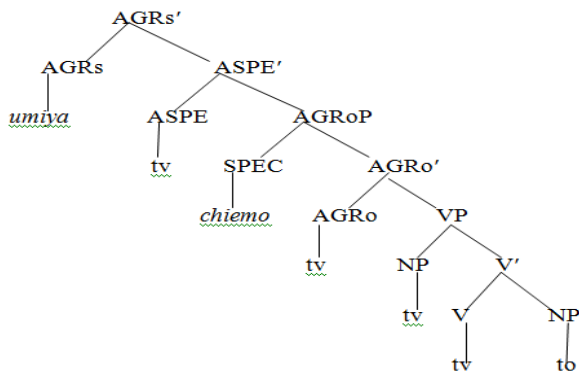

Figure 4: Syntactic Configuration of the Construction, 'umiya chiemo'.

The three arguments that the verb subcategorises for in figure 4 above are checked at their respective heads to satisfy their morphological agreement and case features. Given that the verb hosts the indirect object argument 'a' affixed to it, it moves from inside the VP to AGRo/AGRo' node to check the indirect object agreement features. The verb then moves to ASPE/ASPE' head for progressive aspect feature checking. The movement of the verb ends at AGRs/AGRs' head where the subject agreement feature is checked.

The verb also subcategorises for the free standing direct object argument 'chiemo' that also makes its own movement for its case satisfaction. This argument moves from NP, a position within the VP domain to SPEC/AGRoP head where the accusative case feature of the argument is checked.

Dholuo intransitive verbs subcategorise only for the subject argument, as shown in example (5).

- 5) *wa-se-lem-o*
 1plS-perf-pray-IND
 We have prayed

The verb in the construction in example (5) above hosts only the subject argument 'wa'.

In the MP analysis of the intransitive construction in example (5) above, the AGRs/AGRs' head is created in the MP tree for agreement feature checking. The functional node for the object is not created since the verb operates without an object argument. Consider figure 5.

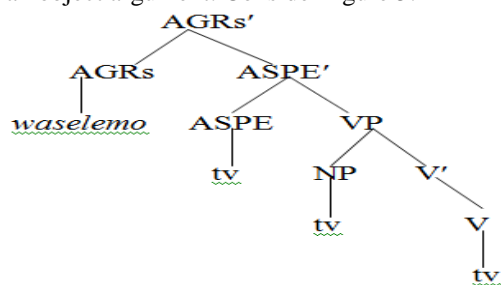

Figure 5: Syntactic Configuration of the Construction, 'waselemo'

In the MP tree in figure 5 above, the verb makes its own movement from inside the VP to ASPE/ASPE' head where the progressive aspect feature is checked. For subject agreement feature checking in this construction, the verb moves to the AGRs/AGRs' head.

A Minimalist Analysis of Dholuo Extended Verbs:-

In Dholuo, some features morphologically expressed as functional are derivational. That means they can change meanings of their host verbs. These features are contained within the derivational morphemes affixed to verbs. Verbal extensions are part of the derivational morphemes because of effects they have on the meaning of their host verbs morphosyntactically. The checking apparatus of the MP gives every verbal extension its own head. The following subsections give an MP analysis of the five Dholuo verbal extensions.

A Minimalist Analysis of Dholuo Verbs with the Applicative Extension:-

The attachment of the applicative suffix to a Dholuo verb introduces an applied object to the matrix of the host verb, as example (6) shows.

- 6) *u-se-wang'-o-n-wa-gi*
 2plS-perf-burn-IND-APPL-1plO-3plO
 You have burned them for us.

The construction in example (6) above can be analyzed by the MP, as shown in figure 6.

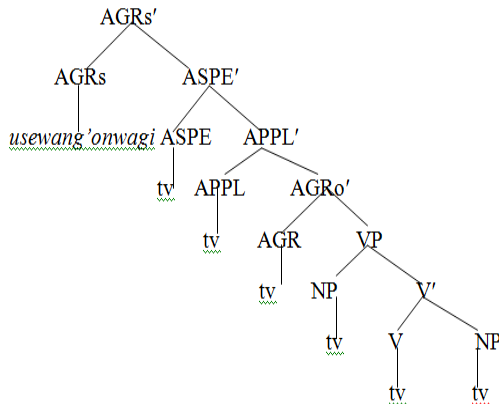

Figure 6: Syntactic Configuration of the Applicative Construction, 'usewang'onwagi.'

The introduction of the applicative extension to a Dholuo verb initiates a creation of a derivational head, the applicative head, in the MP tree. It is at this node where the verb gets its applicative interpretation. The derived verb, as shown in figure 6, first moves from inside the VP to AGRo/AGRo' for the direct object 'gi' and the applied object 'wa' agreement features checking. The verb then makes a move to the APPL/APPL' head. It is at this point where the verb is checked for the applicative feature with the applicative argument 'wa'. For perfective aspect feature checking in the verb stem, the verb moves to the ASPE/ASPE' head. The final move is made by the verb to AGRs/AGRs' head where the subject agreement feature is checked.

Secondly, ditransitive verbs in Dholuo subcategorise for three arguments, the subject argument and the direct and indirect object argument, as example (7) shows.

- 7) *gi-se-kway-o-n-u-wa_gweth*
 3plS-perf-request-IND-APPL-2plO-1plO_ blessing
 They have requested for a blessing from us for you

Syntactically, the construction in example (7) above can be analyzed as shown in figure 7.

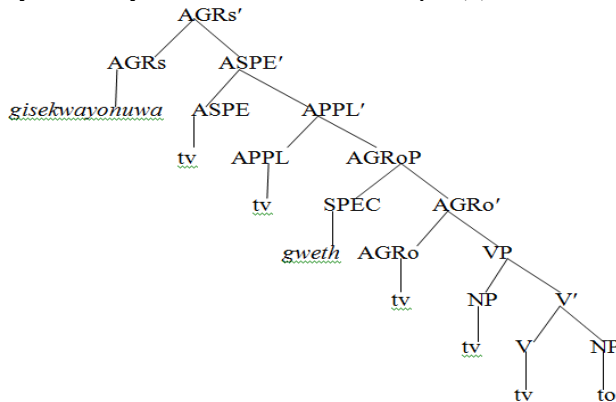

Figure 7: Syntactic Configuration of the Applicative Construction, 'gisekwayonuwa gweth.'

The attachment of the applicative suffix to the ditransitive verb in figure 7 above introduces an applied object argument which is given the derivational head APPL/APPL'. The verb moves from within the VP domain to AGRo/AGRo' head where the object agreement features for both the indirect object argument 'wa' and the applicative argument 'u' are checked. This verbal construction contains an applicative morpheme affixed to it. This causes it to make an obligatory move to the APPL/APPL' head to check for the applicative feature with the applicative argument 'u'. For perfective aspect feature checking, the verb moves to ASPE/ASPE' head. From there the verb moves to AGRs/AGRs' head for subject agreement feature checking. The direct object argument, 'gweth' also makes its own move from within VP to SPEC/AGRoP node to satisfy its own accusative case feature checking.

Finally, Dholuo intransitive verb subcategorises only for a subject argument. The attachment of the applicative suffix to the intransitive verb introduces an applied object argument to the verb, as shown in example (8).

- 8) *a-nind-o-n-e*
 1sgS-sleep-IND-APPL-3sgO
 I am sleeping for him/her/it.

The MP analysis of the construction in example (8) is represented in figure 8.

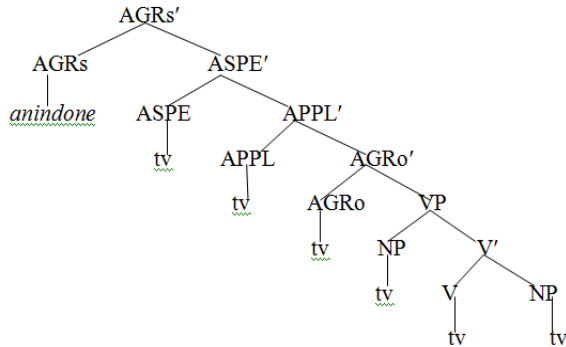

Figure 8: Syntactic Configuration of the Applicative Construction, ‘anindone.’

The affixation of the applicative suffix to the intransitive verb shown in figure 8 above, introduces the applicative argument ‘e’ which must be checked for agreement feature hence the creation of the functional head AGRo/AGRo’. The verb therefore moves from inside the VP to the AGRo/AGRo’ node to check for the object agreement feature. The move then proceeds to APPL/APPL’ node. It is at this point where the applicative feature is checked with the applicative argument ‘e’. From there, the verb moves to ASPE/ASPE’ head where the progressive aspect feature checking takes place. The verb then makes a final movement to the AGRs/AGRs’ node to check the subject agreement feature.

A Minimalist Analysis of Dholuo Verbs with the Locative Extension:-

The locative extension increases the number of arguments of a Dholuo verb by introducing the locative argument ‘e’ to the verb, as shown in the monotransitive construction in example (9).

- 9) *u-hoy-ø-e-e*
 2plS-console-IND-3sgO-LOC
 You are consoling him/her/it at/in a place.

The MP analysis of the construction in example (9) is as shown in figure 9.

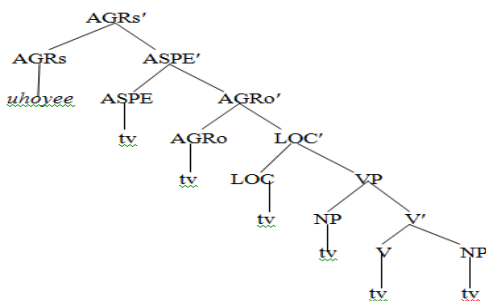

Figure 9: Syntactic Configuration of the Locative Construction, ‘uhoyee.’

The attachment of the locative suffix to Dholuo monotransitive verbs introduces a derivational head, the locative (LOC) where the locative argument of the verb gets its locative interpretation after the checking process. As shown in figure 9 above, the verb first moves from within the VP to LOC/LOC’ head to check for the locative feature with the locative argument ‘e’. The verb then makes a move to AGRo/AGRo’ node for object agreement feature checking. From that node, the verb makes a move to ASPE/ASPE’ for progressive aspect feature checking. The verb finally makes its move to AGRs/AGRs’ node for subject agreement feature checking.

The attachment of locative extension to Dholuo ditransitive verbs increases the number of arguments from the usual three to four. The introduced argument by the locative is referred to as locative argument. Consider example (10).

10) *wa-chul-ø-e-e _pesa*
 1plS-pay-IND-3sgO-LOC _money
 We are paying him/her/it money at/in a place

The MP analysis of the syntactic structure of the construction in example (10) above is as seen in figure 10.

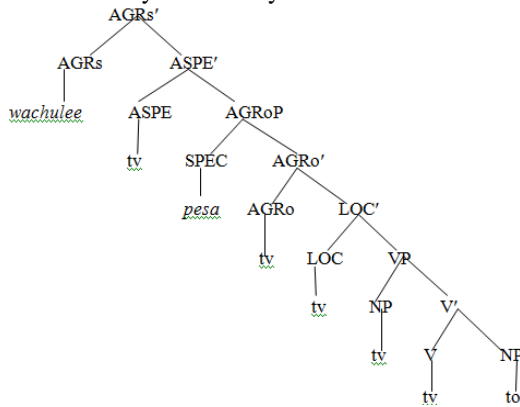

Figure 10: Syntactic Configuration of the Locative Construction, 'wachulee pesa'.

In the MP analysis in figure 10 above, a SPEC. head is created for the direct object 'pesa' since it is a free standing morpheme. The NP 'pesa' therefore moves from NP, a position within the VP to SPEC/AGRoP node for accusative case feature checking. The verb makes its own move from within the VP to AGRo/AGRo' where object agreement feature is checked. For locative feature checking, the verb moves to LOC/LOC' node. From there, the verb moves to ASPE/ASPE' for aspectual feature checking. The move of the verb ends at AGRs/AGRs' where the subject agreement feature is checked.

The locative suffix introduces the locative argument 'e' to a Dholuo intransitive verb thus increasing the number of arguments from one to two, as shown in example (11).

11) *gi-nind-o-e.*
 3plS-sleep-IND-LOC
 They are sleeping in/at a place.

In the MP analysis of the syntactic structure of the construction in (11) above, an MP tree is created as shown in figure 11.

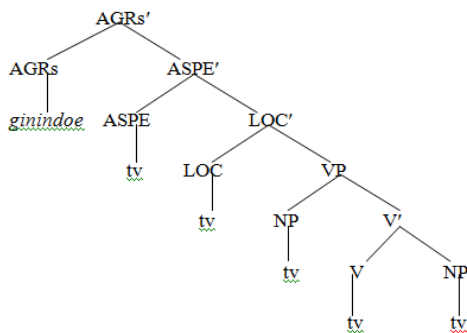

Figure 11: Syntactic Configuration of the Locative Construction, 'ginindoe'.

The introduction of the locative argument to the verb in figure 11 above causes the creation of the derivational head, LOC/LOC'. It is at this node where the verb gets its locative interpretation through the locative feature checking with the locative argument 'e'. The verb then moves to ASPE/ASPE' for aspectual feature checking. A final move is made by the verb to the AGRs/AGRs' node for subject agreement feature checking.

A Minimalist Analysis of Dholuo Verbs with the Reflexive Extension:-

As an argument maintaining extension, an attachment of the reflexive suffix to a Dholuo verb introduces a new argument referred to as the reflexive argument to the matrix of the host verb, as seen in the monotransitive verb in example (12).

- 12) *o-sand-o-r-e*
 3sgS-disturb-IND-**RFL**-3sgO
 He/she/it is disturbs him-/her-/it-self.

On the MP analysis of the syntactic structure in the construction in example (12) above, an MP tree is created, as seen in figure 12.

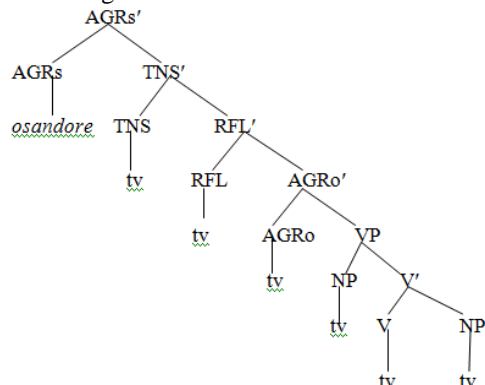

Figure 12: Syntactic Configuration of the Reflexive Construction, 'osandore.'

In the MP analysis of a reflexive construction in Dholuo, a reflexive head (RFL/RFL') is created in the MP tree for the checking of the reflexive feature with a reflexive argument. As shown in figure 12 above, the reflexive extension of the verb introduces the reflexive argument 'e' which must also agree with its antecedent 'o' in terms of number and person. This causes the creation of the inflectional node AGRo/AGRo' for the checking of object agreement feature after the movement of the verb from inside the VP to the object agreement node. The verb then moves from there to the RFL/RFL' node where the reflexive feature is checked with the reflexive argument 'e'. The verb then moves to TNS/TNS' node where the tense feature checking takes place. Finally, the verb moves to AGRs/AGRs' node. It is at this point that the subject agreement feature is checked.

Just like in monotransitive constructions, an attachment of the reflexive suffix to a Dholuo ditransitive verb introduces a new argument-the reflexive argument, as seen in example (13).

- 13) *a-se-chik-o-r-a-gi*
 1sgS-perf-promise-IND-**RFL**-1sgO-3plO
 I have promised myself to them.

In the analysis of the syntactic structure in example (13) above using the MP, figure 13 below is created.

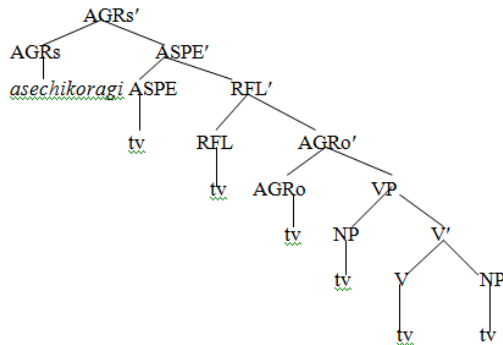

Figure 13: Syntactic Configuration of the Reflexive Construction, ‘asechikoragi.’.

The verb in figure 13 above moves from within the VP domain to AGRo/AGRo’ where the direct object and reflexive argument agreement features are checked. From there, the verb makes its move to RFL/RFL’ head for reflexive feature checking with the reflexive argument ‘a’. From there, the verb moves to ASPE/ASPE’ node for perfective aspect feature checking. The verb finally makes its movement to the AGRs/AGRs’ head where the subject agreement features are checked.

A Minimalist Analysis of Dholuo Verbs with the Reciprocal Extension:-

The reciprocal extension is another argument maintaining operation in Dholuo. On attachment of the reciprocal suffix *-r* to a Dholuo verb, a new argument, the reciprocal argument, is introduced to the matrix of the host verb. Consider a monotransitive verbal construction in example (14).

- 14) *wa-se-chwad-o-r-e*
 1plS-perf-cane-IND-REC-plO
 We have caned each other.

When analyzed under the framework of MP, the construction in example (14) above produces an MP tree shown in figure 14.

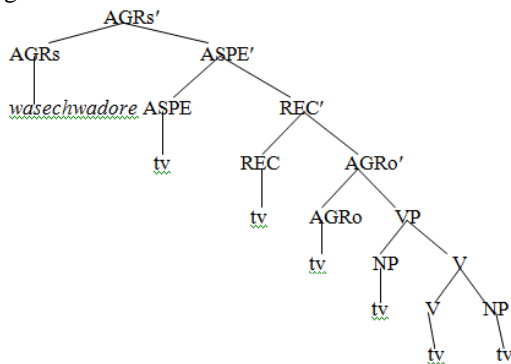

Figure 14: Syntactic Configuration of the Reciprocal Construction, ‘wasechwadore.’

The inclusion of the reciprocal suffix and its argument in the verbal construction causes a creation of the reciprocal head REC/REC’, as seen in figure 14 above. It is at this node where the verbal construction gets its reciprocal interpretation through the checking of reciprocal feature with the reciprocal argument ‘e’. This is after the move of the verb from the VP domain to the AGRo/AGRo’ node where the object agreement feature is checked. The verb then moves to ASPE/ASPE’ for its perfective aspect feature checking. The movement ends at AGRs/AGRs’ where subject agreement feature is checked.

The attachment of the reciprocal suffix to a Dholuo ditransitive verb also introduces a new argument- the reciprocal argument, as seen in example (15).

- 15) *wa-miy-o-r-e_ kony.*
 1plS-offer-IND-REC-plO_ assistance
 We are offering each other assistance

The MP analysis of the syntactic structure in example (15) above is as shown in figure 15.

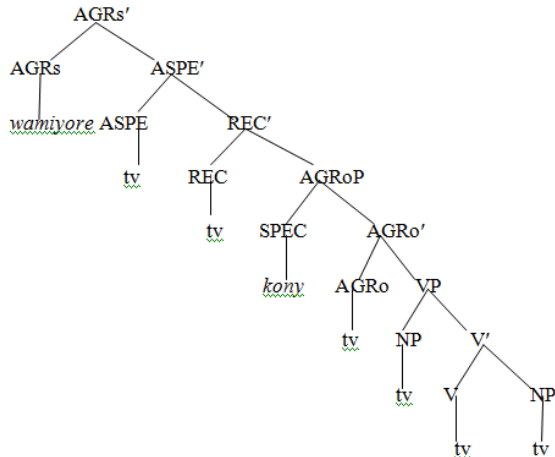

Figure 15: Syntactic Configuration of the Reciprocal Construction, 'wamiyore kony.'

The verb, as shown in figure 15 above, first moves from inside the VP to AGRo/AGRo' to check for object agreement feature. The movement proceeds to REC/REC' head where reciprocal feature with the reciprocal argument 'e' is checked. From there, the verb moves to the ASPE/ASPE' head for progressive aspect feature checking. The verb makes its final move to AGRs/AGRs' node. It is at this head where the subject agreement features in the verb is checked. The presence of a free standing direct object argument 'penjo' causes the creation of the SPEC head, a projection of AGRoP. It is to this node that the direct object 'penjo' makes its own move from NP; a position within the VP, for the accusative case feature checking.

A Minimalist Analysis of Dholuo Verbs with the Stative Extension:-

Dholuo stative extension is an argument reducing operation. As a result of the extension of a verb root with the stative suffix, a di-valent verb is changed to a mono-valent one with the subject argument as the only argument that the stativised verb subcategorizes for. Consider example (16).

- 16) *o-us-o-r-e*
 3sgS-sell-IND-STV-3sgO
 He/she/it can be sold.

In the MP analysis of the stative construction in example (16) above, an MP tree is created as shown in figure 16.

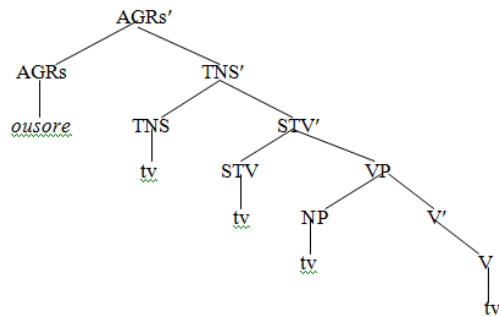

Figure 16: Syntactic Configuration of the Stative Construction, 'ousore.'

The subject agreement head must be created in the MP tree in Dholuo stative constructions since it is important in the checking of the morphological agreement features even though the subject operates as the stative argument in the

construction. In the MP analysis of the monotransitive verb, as shown in figure 16 above, the verb moves from the VP domain to STV/STV' head for stative feature checking with the stative argument 'o'. At this node, the subject argument gets its stative interpretation. From the stative head, the verb moves to TNS/TNS' head for tense feature checking. It is from there that the verb makes a final move to AGRs/AGRs' node for subject agreement feature checking.

The stative extension also operates with Dholuo ditransitive verbs. When this suffix is attached to a ditransitive verb, the number of arguments of the verb is reduced from three to one, as seen in example (17).

- 17) *gi-chul-o-r-e*
 3plS-pay-IND-STV-3sgO
 They are payable.

For the MP analysis of the syntactic features of the stative construction in example in (17) above, an MP tree is created, as shown in figure 17.²

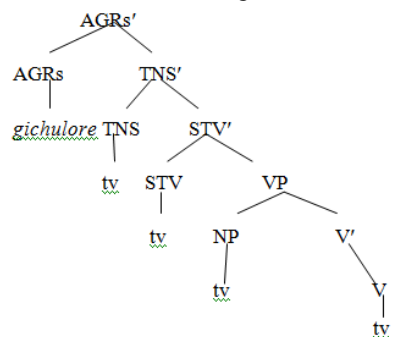

Figure 17: Syntactic Configuration of the Stative Construction, 'gichulore.'

The stativised verb moves from V, a position within VP to AGRo/AGRo' node where the object agreement features are checked. The verb then moves to STV/STV' head for stative feature checking with the stative argument 'gi'. The verb then moves to TNS/TNS' node for tense feature checking. The stative argument should be in agreement with the verb in terms of person and number. This therefore calls for a movement of the verb to AGRs/AGRs' node where the subject agreement features are checked.

Conclusion:-

This article focused on the MP analysis of morphosyntactic features of the five Dholuo verbal extensions. The MP analysis projects these extensions as full projections for the host verbs to check their features in a local configuration. The host verbs move via these projections for full interpretation of these extensions at the LF interface. These movements happen covertly to particular heads where specific lexical items are interpretable. Even though Dholuo verbal extensions introduce arguments, they do not project a specifier position since the arguments are morphological, that is, they are affixed to the host verbs. The Minimalist Program allows for heads to be introduced in Dholuo verbal structure so long as they are licensed by Dholuo.

In the MP analysis of the reflexive, the applicative and the reciprocal extensions in Dholuo verbs, the arguments introduced by these extensions also require the checking of agreement features hence the creation of the object agreement head where the checking happens. The locative argument in Dholuo is not checked for its morphological agreement feature since it does not contain a functional feature but only a derivational feature interpretable at its locative head.

² In terms of argument structure, the result of stativisation is expected to be intransitive. It follows that neither an overt object nor an object marker should be possible in a stative construction. However, in Dholuo an object marker is present. This object marker is non-argumental; it is obligatorily retained here only to define the scope of in situ. In situ is the local domain within which the object marker and the subject fall.

Dholuo stative constructions have an object suffix that is non argumental. This means that in the MP analysis of Dholuo stative constructions, no object agreement head is created, but the subject agreement head is created for the checking of subject agreement feature contained in the stative argument.

References:-

1. Chomsky, N. (1957). *Syntactic Structures*. The Hague: Morton.
2. Chomsky, N. (1965). *Aspects of the Theory of Syntax*. MA: MIT Press.
3. Chomsky, N. (1993). "A Minimalist Program for Linguistic Theory" in: K. Hale and S.J. Kyser (eds), *The view from Building 20: Essays in Linguistics in honor of Sylvain Bromberger*. Cambridge, Mass: MIT Press.
4. Chomsky, N. (1995). *The Minimalist Program*. Cambridge, Mass: MIT Press.
5. Cook, V.J. (Eds) (1988). *Chomsky's Universal Grammar*. Crystal, D. and Johnson, K. Oxford: Blackwell publishers.
6. Cook, V.J., & Newson, M. (1996). *Chomsky's Universal Grammar: An Introduction*. Oxford: Blackwell Publishers.
7. Dimmendaal, G. J. (1983). Datives in Nilotic in a Typological perspective. University of Cologne. Available online at HYPERLINK "<http://urn:nbn:de:ooo9-235>"<http://urn:nbn:de:ooo9-235>
8. Gahutu, P. (2012). *Tense, Aspect and Modality Systems in Kihavu: A Minimalist perspective*. Unpublished PhD Dissertation, Kenyatta University. Nairobi.
9. Harns, Z. S. (1951). *Structural Linguistics*. Chicago: University of Chicago.
10. Hornstein, N. (1995). *Logical form: from Government and Binding to Minimalism*. Oxford UK & Cambridge USA: Blackwell.
11. Hornstein, N. et al (2005). *Understanding Minimalism*. New York: Cambridge University Press.
12. Jan-Wouter, Z. (1998). *The Minimalist Program. The Review Article*. Cambridge: 213-226. Cambridge University Press.
13. Lyons, J. (1968). *Introduction to Theoretical Linguistics*. Cambridge: Cambridge University Press.
14. Matellán, V.A. (2010). *Argument structure and syntax-morphology interface. A case study in Latin & other languages*. PhD Dissertation. Universitat de Barcelona.
15. Mc Call, B. (1999). *Luo Verb Morphology: A Description and an Optimality-Theoretic Account*. Field Methods 2.
16. Ochola (2003). *A Morphosyntactic Analysis of Dholuo verbal system*. Unpublished MA Thesis, University of Nairobi.
17. Omondi, L. (1982). *The major syntactic structure of Dholuo*. Berlin: Dietrich Reimer Verlag.
18. Pollock, J.K. (1989). *Verb Movement, Universal Grammar, and the structure of IP* in. *Linguistic Inquiry*, 20(3): 365-424.
19. Radford, A. (1997). *Syntactic Theory and the Structure of English: A Minimalist Approach*. Cambridge: Cambridge University Press.
20. Schroeder, H. (2002). *A Word Order in Toposa. An Aspect of Multiple Feature Checking*. PhD Dissertation: University of Nairobi.
21. Suleh (2013). *A Morphosyntactic Analysis of Ambiguity of Mood in Dholuo*. Unpublished PhD Thesis, University of South Africa.
22. Welbelhuth, G. (1995). *Government and Binding theory and the Minimalist Program: Principles and Parameters in Syntactic Theory*. Oxford: Blackwell.