



Journal Homepage: -www.journalijar.com
**INTERNATIONAL JOURNAL OF
 ADVANCED RESEARCH (IJAR)**

Article DOI:10.21474/IJAR01/7378
 DOI URL: <http://dx.doi.org/10.21474/IJAR01/7378>



RESEARCH ARTICLE

SEGMENTATION OF LOAD GROUPS ON A SINGLE PHASE KWH-METER USING THE PAYLOAD DATA HANDLING SYSTEM.

Arief Goeritno¹, Joki Irawan¹, and Sopyandi².

1. Full-time Lecturer at Electrical Engineering Study Program, Bogor Ibn Khaldun University.
2. Assistant at Instrumentation and Automation Laboratory, Electrical Engineering Study Program.

Manuscript Info

Manuscript History

Received: 20 June 2018
 Final Accepted: 15 July 2018
 Published: July 2018

Keywords:-

Segmentation of load groups on a single-phase kWh-meter, microcontroller, payload data handling system.

Abstract

A minimum system that controlled by microcontroller has been established for load groups segmentation on a single-phase kWh-meter using the payload data handling system. Minimum system that controlled by microcontroller is integration of all entities through handshake mechanism for hardware and software. Handshaking the hardware in the form of a board for microcontroller ATmega32 with the availability of five ports each for 5 volt dc power connector, sensor, LCD 4x16, downloader, and output. The handshaking the software is the presence of programming to the ATmega32 microcontroller for system operation based-on BasCom language programming through seven stages: (i) pins configuration, (ii) variable declaration, (iii) declaration of constants, (iv) initialization, (v) main program, (vi) retrieve and send data, and (vii) output. System performance is shown, that the selection of electric load groups is very important, in order to know the value when measuring and remain accurate, not changing. Control system based-on payload data handling is capable of applying the value of the current of several examples of electric load group points according to the ability of the sensor. One current value with a value of 0.40 or equivalent to a voltage value of 4.47 volts is indicated, that the control system for example of electric load group point by measuring the current value can be considered feasible, if the voltage value is in the range of 220 volts ac.

Copy Right, IJAR, 2018,. All rights reserved.

Introduction:-

Monitoring against the electric energy usage based-on the readings of an electric meter that measures the current passing through the service entrance into the electrical service panel, used the kWh-meter [1]. Using the traditional electric meter (called mechanical analog meter), only records the amount of electricity that has passed through it since it was first installed or last reset by the utility service company. For a number of load groups with each of which stands independently on a single-phase kWh-meter, the electric energy usage can be done manually for each group, but it is inefficient, as it requires human resources as a recorder of the measurements of current and voltage from measuring devices for all times [1]. The monitoring can also be carried out by installing the kWh-meter for each load group, but it affects additional costs for the procurement of new kWh-meter and still requires human resources for recording and computation [1]. Today a number of devices with minimum system that technology controlled or microcontroller-based electronic systems have been created and developed, targeted for ease of work

Corresponding Author:-Arief Goeritno.

Address:- Jl.K.H. Sholeh Iskandar km.2, Kedung Badak, Tanah Sareal, City of Bogor, WJ, Indonesia

and reduction of human's load and portion [2]. Microcontroller is a chip containing electronic devices with cheap computers, small, and large capability through the program storage in its [3]-[12]. Electronic devices based-on microcontroller system using the Payload Data Handling (PDH) system is a control system for monitoring, storage, delivery, and reception of data that operate automatically through remote or close control system [4],[12]-[14].

The electric energy meter is absolutely installed [15]-[18] in every house or building of electricity customer of PT PLN (Electricity State Company). The kWh-meter function counts how much electricity a customer consumes, whether at home, office, or factory [19]. The value is calculated in kWh-meter each month multiplied by the unit price of the basic electricity tariff (called is TDL). Monitoring the use of electrical energy on a single-phase kWh-meter used for one load group is very easy and there are not many obstacles, because it is in accordance with the designation. In contrast to the pursuit of one kWh-meter for load groupings or a group of people seeking only one kWh-meter is used for more than one group of electrical loads in households or elsewhere. It becomes more difficult to monitor the use of electrical energy used, because it affects the determination of the cost of electricity tariffs, and the behavior of electric users themselves [20].

Based-on this background, it is necessary to fabricate a minimum system based-on microcontroller that integrated into a single-phase kWh-meter for monitoring and recording the use of electrical energy in each load group. Schematic diagram of minimum system based-on microcontroller using PDH system for segmentation of 4 (four) load groups, as shown in Figure 1.

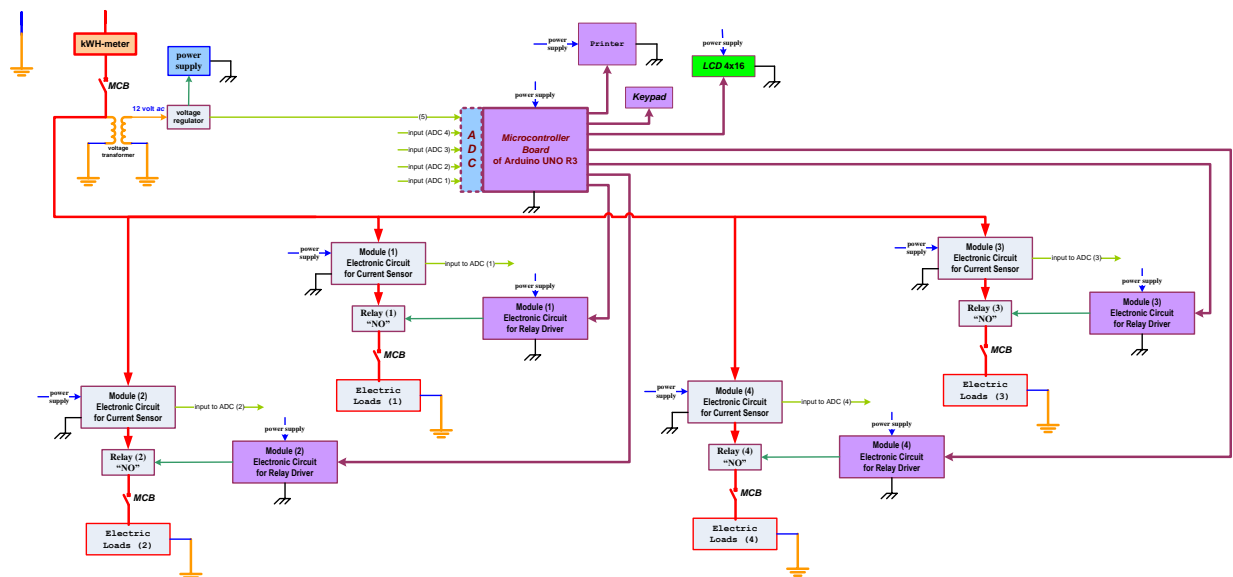

Figure 1:-Schematic diagram of minimum system based-on microcontroller using PDH system for segmentation of 4 (four) load groups

Based-on Figure 1 shown, that the objectives of this research is to a) physical form of the integrated system and programming against the microcontroller system that according to Payload Data Handling (PDH) system and b) obtain of the result for verification and validation test through performance measurement to electronic system with artificial condition.

Method of Research:-

For the continuity of the research method, a number of research materials are needed, including: (i) microcontroller, (ii) a number of relay modules; (iii) a number of resistors and transistors; (iv) a number of pin cables, (v) breadboard, (vi) (vii) miniature circuits breaker (MCB), (ix) power supply, and (x) programming language based-on Basic Compiler (BasCom). In addition to research materials, research tools are needed at the time of the research implementation: Google Chrome web browser, Core2Duo P7370 2.00 GHz laptops, and measuring instruments of voltage (voltmeter) and electric current (ammeter). The research method is the stages for the acquisition of a number of research objectives. The flowchart of the stages of implementation for research method, as shown in Figure 2.

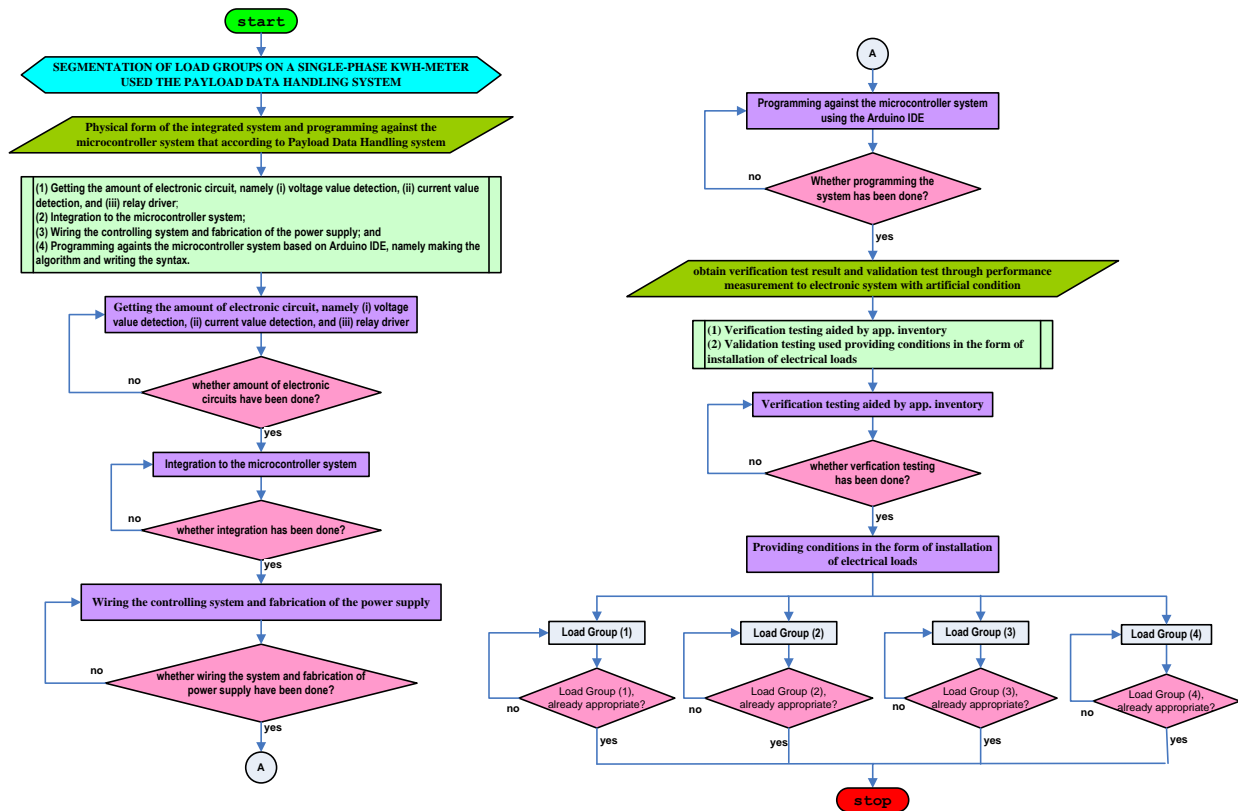

Figure 2:-The flowchart of the stages of implementation for research method

Based-on Figure 2 shown, that the stages of the implementation of research method, there are 2 main stages in accordance with the objectives of the research. Integration for an electronic system and programming to microcontroller system using the Payload Data Handling system is done with the steps, namely: (1) Amount of electronic circuit as modules: (i) voltage value detection, (ii) current value detection, and (iii) relay for actuator driver; (2) Integration to the microcontroller system; (3) Wiring the controlling system and fabrication of the power supply; and (4) Programming against the microcontroller system based-on the BasCom language, namely obtaining the algorithm and writing the syntax. Verification and validation tests are measurements through the performance of electronic systems with the provision of artificial conditions using app inventory and minimum system performance measured by the provision of artificial conditions performed on each power path to the load group.

Result and Discussion:-

Two research results are based-on research objectives, namely (i) result of integration for a system and programming to microcontroller system according to Payload Data Handling system and (ii) results of the verification test and the validation test through by the provision of artificial conditions.

Integration for an Electronic System and Programming of Microcontroller System Based-on the Payload Data Handling System:-

The integration begins with the fabrication of each electronics circuit in the form of boards for voltage detection, current detection, and relay for actuator driver modules. The manufacture of boards for microcontrollers, control system wiring and power supply fabrication, and programming against microcontroller based-on BasCom language.

Electronic system based-on microcontroller:-

Components for the requirements in the manufacture of voltage detection module, namely: 1N4001 diode, 330k resistor, 0.1 μF capacitor, 47 μF, 10 μF, NPN BD139 transistor, and regulator IC. The series of electronics is

connected to a voltage source of 220 volts from the “PLN” power supply. The physical form of the detection of voltage value, as shown in Figure 3.



Figure 3:-The physical form of the detection of voltage value

The current sensor module consists of a number of electronic components used, namely 1N4004 diodes, capacitors, and a number of 330k resistors with inputs taken from a 220 volt ac voltage source through a T-block connector and an electronic circuit output connected to input port of a analog to digital converter (ADC) on microcontroller. The output value of the current sensor is 100 mV/A for the readout of the electrical loads displayed on the LCD. The physical form of the module for the current sensor, as shown in Figure 4.



Figure 4:-The physical form of the module for current sensor

The relay drive module consists of connectors (T-block), relays, transistors, and diodes. Connectors installed in each auxiliary contact to the load and ACS712 current sensor. Relay coils are supplied from a power supply with a 12 volt dc. Each relay operates after obtaining a signal from the microcontroller and the operating results are sent to the microcontroller through the same wire (bidirectional). The physical form of the modules that consist of relays for the actuator driver, as shown in Figure 5.



Figure 5:-The physical form of the shape of the relay drive module

The layout view of the components on the board for the ATmega32 microcontroller system is done through the drilling and soldering stages of the component legs. The physical form of the board and the layout of electronic components for the ATmega32 microcontroller system, as shown in Figure 6.

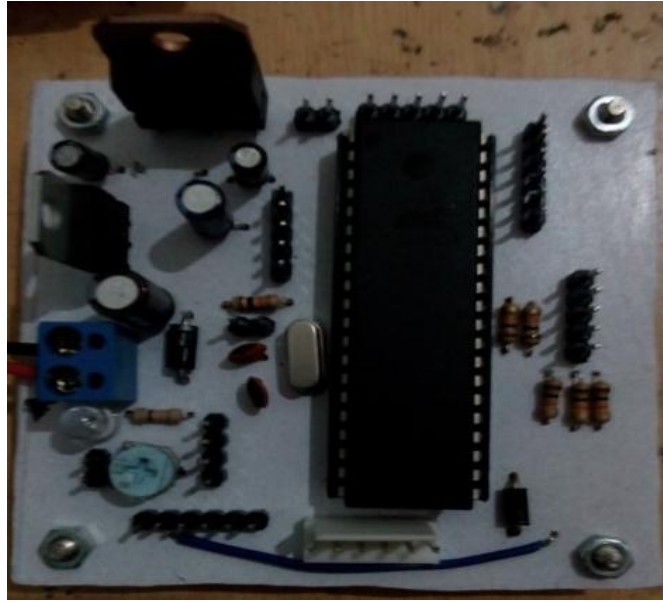

Figure 6:-The physical form of the board and the layout of electronics components for the ATmega32 microcontroller system

Based-on Figure 6 shown, that the board is used for electronic components as required including ATmega32 microcontroller chip, 10k variable resistor, 2.2 nF capacitor, crystal oscillator for 12 MHz. frequency, and pins for header.

Wiring the minimum system for controlling the overall load groups, as shown in Figure 7.

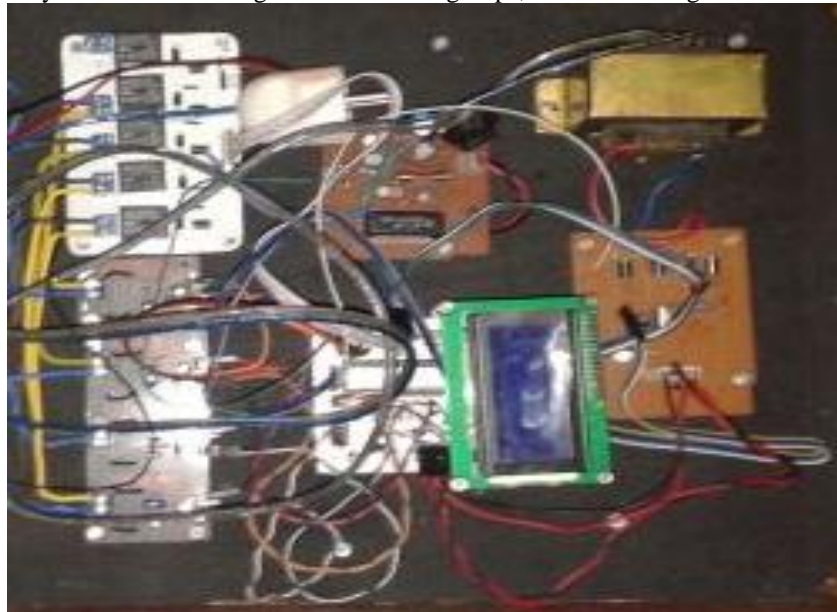

Figure 7:-Wiring the minimum system for controlling the overall load groups

Based-on Figure 7 shown, that the serial data pins connected to the microcontroller provide addressing commands on the sensor data pins for the measurement of voltage detection and current measurements. The pins used in the detector and sensor module are located on the D-port, with 8 pins available but only used 5 pins, namely D0, D1, D2, D3, and D4. For connection to the LCD, located on the C-port, with 8 pins available but only used 6 pins, namely C0, C2, C4, C5, C6, and C7.

The power supply is very important for the operation of a number of electronic components, so that for the purposes of microcontroller and other supporting components used transformer secondary side voltage system at 12 volt ac value. The physical form of the power supply, as shown in Figure 8.

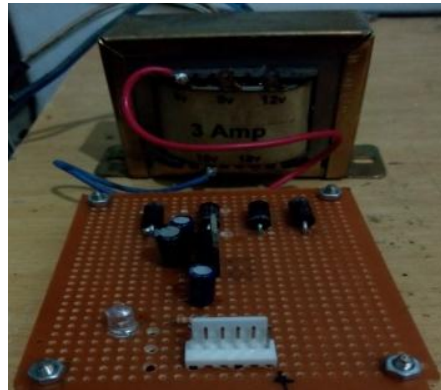

Figure 8:-The physical form of power supply

Based-on Figure 8 shown, that the power supply is used for power supply to the sensor-transducer system, ATmega32 microcontroller system, relay modules, and LCD 4x16. The measurement result of the 5 dc power supply from the regulator is known, that the output voltage is no load at an average value of 4.9 volts dc and the output voltage with the load at an average value of 4.8 volts dc, so that the voltage on the power supply for the microcontroller system relatively constant.

Programming the ATmega32 microcontroller based-on BasCom AVR language:-

The program used in the prototype detection system of excess electrical power assisted voltage detector and microcontroller-based current sensors, namely the BasCom language. BasCom's main function to compile the program code into hexa-decimal (machine language). Programming the ATmega32 microcontroller is done through the determination and making algorithm and writing syntax that ends with verification test of the program that has been made into the Proteus application. Making the algorithm is based-on the flowchart method. The whole programming flowchart against the ATmega32 microcontroller system, as shown in Figure 9.

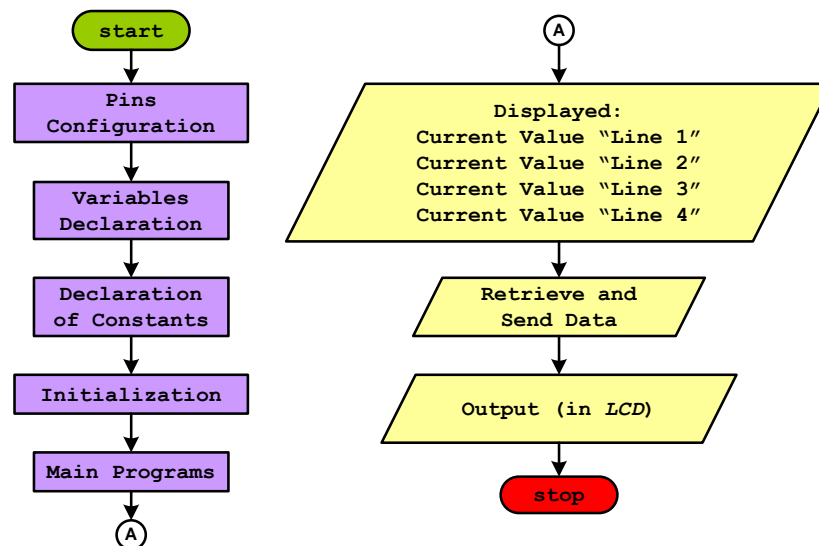

Figure 9:-The whole programming flowchart against the ATmega32 microcontroller system

Based-on Figure 9 shown, that the programming algorithm consists of 7 (seven) stages: i) pins configuration, ii) variables declaration, iii) declaration of constants, iv) initialization, v) main program, vi) retrieve and send data, and vii) output.

The syntax is written in BasCom according to the stages of the algorithm.

Pins configuration:-

Pin configuration is the determination of the pins used, both as input and output. The pins are used as parameters in each addressing program for pin determination of ATmega32, for both voltage detection, current sensor, relay driver, and 2x16 LCD. The syntax of the program on the pin configuration, namely:

```
Config Lcdpin = Pin
Db4 = Portb.4
Db5 = Portb.5
Db6 = Portb.6
Db7 = Portb.7
E = Portb.2
Rs = Portb.0
Config Adc = Pin
Adc1 = Portc.0
Adc2 = Portc.1
Adc3 = Portc.2
Config Lcdpin = Pin
Db4 = Portb.4
Db5 = Portb.5
Db6 = Portb.6
Db7 = Portb.7
E = Portb.2
Rs = Portb.0
Config Adc = Pin
Adc1 = Portc.0
Adc2 = Portc.1
Adc3 = Portc.2
```

Declaration of variables:-

Variable declarations are performed for declarations of the type of data being worked on. The syntax of the program on the variable declaration, namely:

```
Start Adc. .
Dim Voltage As Byte
Dim Cont_sk1 As Byte, Cont_sk2 As Byte, Cont_sk3 As Byte, Cont_lamp As Byte,
Dim Ask1 As Byte, Ask2 As Byte, Ask3 As Byte, Alamp As Byte
Dim Sk1 As Single, Sk2 As Single, Sk3 As Single, Lamp As Single
```

Declaration of constants:-

Constant declaration is a constant value assignment on the program based-on the datasheet of the sensor which is the input on the system of minimal microcontroller load current control based-on ATmega32. The declaration of the immediate constants mentioned large values. The declaration of a constant is not used as a colon (:) as in the variable declaration, but used the sign equal to (=). The syntax of the program on the declaration of constants, namely:

```
Config Portc = Output
In_tension of Getion Alias (0)
In_sk1 Alias Getadc (1)
In_sk2 Alias Getadc (2)
In_sk3 Alias Getadc (3)
In_lamp Alias Getadc (4)
Pb_sk1 Alias Pind.3
Pb_sk2 Alias Pind.4
Pb_sk3 Alias Pind.5
Pb_lamp Alias Pind.6
Out_sk1 Alias Portc.3
Out_sk2 Alias Portc.4
Out_sk3 Alias Portc.5
Out_lamp Alias Portc.6
```

Initialization:-

Initialization is the initial initialization of the program created for each command status in the program. This initialization is expected to be a shortcut command on the next program. Program syntax on initialization, ie:

```
Locate 1, 1
Lcd "power line"
```

```

Wait 3
Locate 2, 1
Cls
Do
Ask1 = In_sk1
Ask2 = In_sk2
Ask3 = In_sk3
Alamp = In_lamp
If Pb_sk1 = 0 Then
Cont_sk1 = Cont_sk1 + 1
Do
Loop Until Pb_sk1 = 1
Elseif Pb_sk2 = 0 Then
Cont_sk2 = Cont_sk2 + 1
Do
Loop Until Pb_sk2 = 1
Elseif Pb_sk3 = 0 Then
Cont_sk3 = Cont_sk3 + 1
Do
Loop Until Pb_sk3 = 1
Elseif Pb_lamp = 0 Then
Cont_lamp = Cont_lamp + 1
Do
Loop Until Pb_lamp =

```

Main program:-

The main program is the source of program control, since all commands in the program are sequenced starting from the initial view, retrieving the data, showing the data on the LCD that is affected by the reaction or output (output) of the program created. Program syntax in the main program, namely:

```

Locate 1, 1
Lcd "sk1 ="; Fusing (sk1, "#. ##"); "Amp"
Locate 2, 1
Lcd "sk2 ="; Fusing (sk2, "#. ##"); "Amp"
Locate 3, 1
Lcd "sk3 ="; Fusing (sk3, "#. ##"); "Amp"
Locate 4, 1
Lcd "lmp ="; Fusing (lmp, "#. ##"); "Amp"

```

Retrieve and send data:-

Data retrieval is done until data acquisition changes, after which the data is sent and then displayed on the LCD.

Output:-

Program output is the reaction caused by the sensor, to be displayed on the LCD.

Verification and Validation Test through Electronic System Performance Measurement by Provision of Artificial Conditions:-

Verification test:-

Verification tests of BasCom-based language programs are done with the help of the Proteus application program. The prototype circuit controlling system is first assembled with the help of the Proteus application program, then the program that has been created with BasCom language compile into hex or machine language form and downloaded into the circuit. The voltage and current detected in the simulation can be arranged in accordance with the desired for verification, whether the program has been made as expected or not. Display on the verification test, as shown in Figure 10.

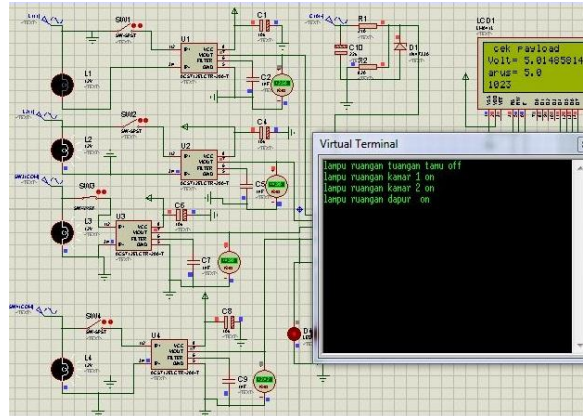

Figure 10:-Display on verification test

Based-on Figure 10 shown, that the verification test based-on Proteus application against the the program based-on BasCom language has been made, which for the voltage sensor depends on the given input voltage setting and for the current value depends on the setting of the variable resistor in the simulation. Programs that have been created and have been simulated according to expected results.

Validation test:-

Minimum system based-on microcontroller using Payload Data Handling system put on the form of box with dimension 50 cm x 30 cm x 15 cm for the placement of transformers, microcontroller-based system, sensor-transducer, and LCD 4x16. Performance measurement of the system is done through the provision of artificial conditions. Physical form of the minimum system based-on microcontroller using the Payload Data Handling system for 4 load groups on a single-phase kWh-meter, as shown in Figure 11.

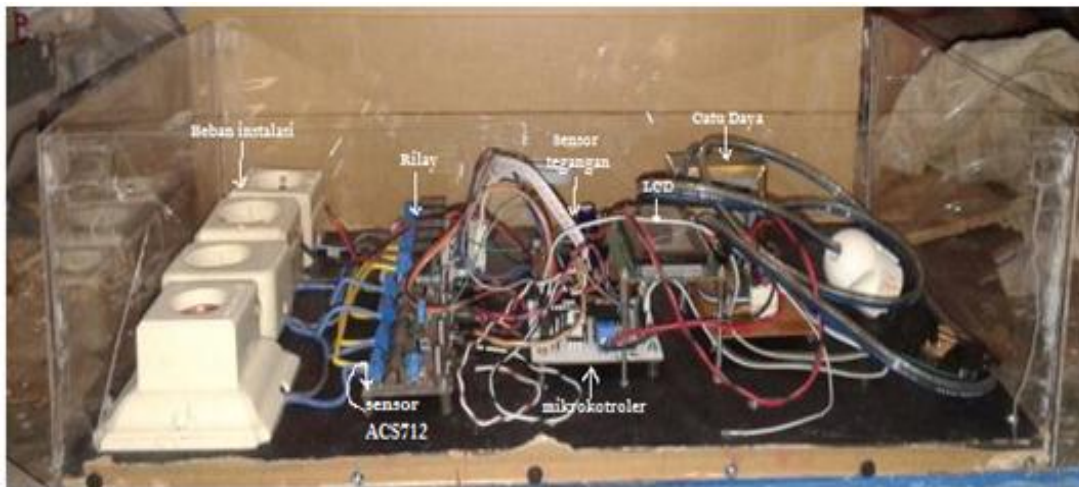

Figure 11:-Physical form of the minimum system based-on microcontroller using the Payload Data Handling for 4 load groups on a single-phase kWh-meter

Load changes occur when the voltage value is detected with the current value changes. Voltage and current measurements are carried out with an electrical load, so that voltage and current changes are detected, then information about the voltage and current values has been reached at a certain value. The measured voltage value in the form of a decimal number as an 8-bit binary number conversion and the measured current value of ampere (A). Measurement of measurement results, displayed via LCD 4x16. The measured voltage and current values correspond to the detected state. For the use of loads that exceed the limit, it is detected by the current sensor.

System performance measurements were performed on several sample installation points, including 1) “sk1”, 2) “sk2”, 3) “sk3”, and 4) “lmp”. The display of measurement results of a number of electrical loads as representation of each load group, as shown in Figure 12.

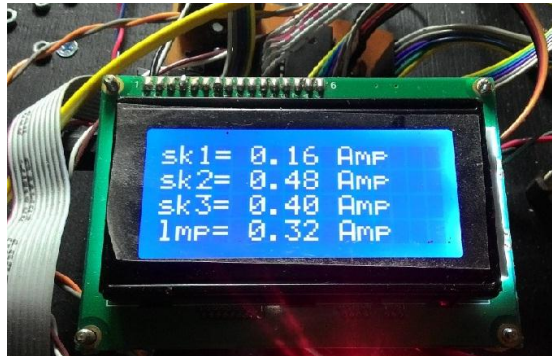

Figure 12:-The display of measurement results of a number of electrical loads as representation of each load group

Based-on Figure 12 shown, that the load is attached to the load group “sk1” with the result of measurement to the load with the current value according to the sensor capability of 0.16 amperes. The measured current value has been changed from the usage load value, worth 4.19 volts. For the current value contained in the load, where the result of the sensor measurement is influenced by the current value contained in the load, the load increase is proportional to the value of the detected current. The load is attached to the “sk2” load group with the measurement result to the load with the current rating according to the sensor capability, of 0.4 amperes. The measured current value has been changed from the usage load value, worth 4.47 volts. For the current value contained in the load, where the result of the sensor measurement is influenced by the current value contained in the load, the load increase is proportional to the value of the detected current. The load is attached to the “sk3” load group with the measurement result to the load with the current value according to the sensor capability of 0.24 amperes. The measured current value has been changed from the usage load value, worth 4.35 volts.

For the current value contained in the load, where the result of the sensor measurement is influenced by the current value contained in the load, the load increase is proportional to the value of the detected current. The load is attached to the “lmp” load group with the measurement result to the load with the current rating according to the sensor capability, of 0.32 amperes. The measured current value has been changed from the usage load value, worth 4.41 volts (in the form of 8 bit digital value). For the current value contained in the load, where the result of the sensor measurement is influenced by the current value contained in the load, the load increase is proportional to the value of the detected current.

Based-on the measurement of the measured current values shown on the LCD as the measurement result of the control system based-on Payload Data Handling assisted microcontroller for the load group on the electrical installation of the dwelling house with only one kWh-meter. Measured voltage at each of the 214 volt ac power supply terminals. The result of measuring the current value detected by the ACS712 current sensor, as shown in Table 1.

Table 1:-Measurements of current values detected by ACS712 current sensors

No.	Load Group	Current Values (ampere)
1	sk1	0,16
2	sk2	0,40
3	sk3	0,24
4	lmp	0,32

Conclusion:-

Based-on the results and the discussion can be concluded, that the minimum system for controlling the segmentation of the 4 load groups on a single-phase kWh-meter controlled microcontroller system using the Payload Data Handling system has been in accordance with the research objectives.

Integration for the existence of all entities as parts of the system-based minimal formation of ATmega32 microcontroller system is shown, that the board for microcontroller ATmega32 provided five ports each for 5 volt dc power connector, sensor, LCD 4x16, downloader, and output. The five ports are input (input) and output (output) derived from pin ATmega32. There is one power supply for the purposes of microcontroller and other supporting components, namely power supply with 12 volt voltage system Ac with 2 ampere current. The result of the measurement of the 5 volt dc power supply of the regulator is known, that the output voltage is no load at an average value of 4.9 volts dc, while the output voltage with load at an average value of 4.8 volts dc. ATmega32 microcontroller programming for system operation, BasCom-based programming is implemented through eight stages: (i) pins configuration, (ii) variable declaration, (iii) declaration of constants, (iv) initialization, (v) main program, (vi) retrieve and send data, and (vii) output.

The simulated results of the Proteus application are shown, that the simulation results are approached as expected, for current sensors which depend on the given input voltage setting, and the current depends on the settings with the variable resistors in the simulation. Measurements on the performance of the system are shown, that the selection of electric load groups is very important, in order to know the value when measuring and remain accurate, not changeable. Control system based-on payload data handling is capable of applying the value of the flow of several examples of electric load group points according to the ability of the sensor. One current value with a value of 0.40 or equivalent to a voltage value of 4.47 volts is indicated, that the control system for example of electric load group point by measuring the current value can be considered feasible, if the voltage value is in the range of 220 volts ac.

References:-

1. T. Thiele. (2018, April 7). How An Electric Meter Reads Power Usage. The Spruce Com. [Online]. Available: <https://www.thespruce.com/how-electric-meters-read-power-1152754>.
2. L. Subekti and A.M. Akhyari, "Prototipe Sistem Prabayar Energi Listrik Untuk Kamar Kost Berbasis Mikrokontroler," in *Prosiding Simposium Nasional Rekayasa Aplikasi Perancangan dan Industri (RAPI) XII 2013*, FT-UMS, pp. E-52-E-61. [Online]. Available: https://publikasiilmiah.ums.ac.id/bitstream/handle/11617/4175/TE8_LukmanS_SV_UGM.pdf?sequence=1&isAllowed=y.
3. A. Goeritno, D.J. Nugroho, and R. Yatim, "Implementasi Sensor SHT11 Untuk Pengkondisian Suhu dan Kelembaban Relatif Berbantuan Mikrokontroler," in *Prosiding Seminar Nasional Sains dan Teknologi (Semnastek) 2014*, Fakultas Teknik, Universitas Muhammadiyah Jakarta, 14th November 2014. 1, pp. (TE-009) 1-13. [Online]. Available: <https://jurnal.umj.ac.id/index.php/semnastek/article/view/233/208>.
4. Sopyandi, A. Goeritno, and R. Yatim, "Prototipe Sistem Pengontrolan Berbasis Payload Data Handling Berbantu Mikrokontroler Untuk Instalasi Listrik Rumah Tinggal," in *Prosiding Seminar Nasional Teknologi Industri (SNTI) V-2016*, Fakultas Teknologi Industri Universitas Trisakti Jakarta, pp. 331-337.
5. S.F. Ginting, A. Goeritno, and R. Yatim, "Kinerja Sistem Pengontrolan Berbantuan Sensor Voice Recognition dan Mikrokontroler ATmega16 untuk Pengoperasian Aktuator," in *Prosiding SNTI V-2016 Universitas Trisakti*, Jakarta, 18th May 2016, pp. 359-365.
6. A. Goeritno, R. Effendi, and R. Yatim, "Implementasi *Contacting Conductivity Sensor* dan *Thermistor* Berbasis Mikrokontroler ATmega32 Untuk Pendeteksian Awal Kualitas Air," di *Prosiding Seminar Nasional Sains dan Teknologi (Semnastek) 2016*, Fakultas Teknik, Universitas Muhammadiyah Jakarta, 8th November 2016, pp. (TE-018) 1-12. [Online]. Available: <https://jurnal.umj.ac.id/index.php/semnastek/article/view/693/624>.
7. A. Goeritno, B.A. Prakoso, and B.A. Prakosa, "Kinerja Sistem Kontrol Berbasis Mikrokontroler Untuk Pemantauan Sejumlah Parameter Fisis pada Analogi Smart Green House," di *Prosiding Simposium Nasional Rekayasa Aplikasi Perancangan dan Industri (RAPI XV) 2016*, Fakultas Teknik, Universitas Muhammadiyah Surakarta, 7th December 2016, pp. 70-76. [Online]. Available: https://publikasiilmiah.ums.ac.id/bitstream/handle/11617/8172/B49_Arief%20Goeritno.pdf?sequence=1&isAllowed=y.
8. A. Goeritno, B.A. Prakosa, and B.A. Prakosa, "Tampilan Sejumlah Parameter Fisis pada Analogi *Smart Greenhouse* Berbantuan Mikrokontroler ATmega32, Bluetooth, dan *Smart Phone* Berbasis Android," di *Prosiding Seminar Nasional Multidisiplin Ilmu*, Universitas Budu Luhur, Jakarta, 22nd April 2017, pp. (ICT) 225-234.
9. A. Goeritno and I. Mustofa, "Minimum System Berbasis Mikrokontroler ATmega32 Untuk Pemantauan dan Tampilan Kondisi Instalasi Kelistrikan Otobis," in *Jurnal Ilmiah Setrum*, Vol. 6, No. 1, Juni 2017, pp. 55-67. [Online]. Available: <https://jurnal.untirta.ac.id/index.php/jis/article/view/1721/2122>.

10. A. Goeritno, S.F. Ginting, and R. Yatim, "Pengoperasian Beban Listrik Fase Tunggal Terkendali melalui Minimum System Berbasis Mikrokontroler dan Sensor Voice Recognition (VR)," in *Prosiding SNATIF 2017*, Fakultas Teknik Universitas Muria Kudus, 25th July 2017, pp. 63-78. [Online]. Available: <https://jurnal.umk.ac.id/index.php/SNA/article/view/1244/862>.
11. M.Y. Afandi, A. Goeritno, and R. Yatim, "Minimum System Berbasis Mikrokontroler ATmega32 Berbantuan Sensor Passive Infrared Receiver dan Fingerprint Untuk Sistem Pengamanan Kendaraan Bermotor Roda Empat atau Lebih," in *Prosiding SNATIF 2017*, Fakultas Teknik Universitas Muria Kudus, 25th July 2017, pp. 195-210. [Online]. Available: <https://jurnal.umk.ac.id/index.php/SNA/article/view/1264/879>.
12. A. Goeritno, Sopyandi, and R. Yatim, "Beban-beban Listrik Terkontrol melalui Minimum System Berbasis Payload Data Handling Berbantuan Mikrokontroler," dalam *Prosiding Seminar Nasional Teknologi dan Informatika (SNATIF) ke-4 Tahun 2017*, Fakultas Teknik Universitas Muria Kudus, pp. 223-238. [Online]. Available: <http://jurnal.umk.ac.id/index.php/SNA/article/view/1270/882>.
13. L. Zhou, and J. An, "Design of Payload Data Handling System for Satellites," in *Proceeding 2013 Third International Conference on Instrumentation, Measurement, Computer, Communication and Control (IMCCC)*, Shenyang, China, 21-23 Sept. 2013, pp. 1217-1220.
14. A.H. Syafrudin, *Sistem Payload Data Handling*, Bogor: Pusat Teknologi Satelit - LAPAN, 2016.
15. G.W.D. Ricks, "Electricity Supply Meters," in *Journal of the Institution of Electrical Engineers*, 25 (120), (March 1896), pp. 57-77.
16. J.A. Fleming, *Magnets and Electric Currents*. New York, NY: Spon & Chamberlain, 1914, p. 335.
17. H.W. Beaty and D.G. Fink, "Electric and Magnetic Circuit," in *Standard Handbook for Electrical Engineers*, (Fourth Edition, First Printing). New York: McGraw Hill, 1915, pp. 58-59.
18. T. Croft and W.I. Summers, "Fundamental," in *American Electricians' Handbook* (Eleventh Edition). New York: McGraw Hill, 1987, pp. 1-8.
19. W.H. Hardy, "Introduction to Metering," in *Power Measurements Handbook*, 4th Printing. Gainesville, VA: Power Measurements, 2013, pp. 17-26.
20. R.L. Holt and C.J. Larson. (2008, Nov.). "Consumers' Attitude toward Energy Conservation and Energy Efficiency: The Role of Electric," in *Florida Focus*. 4(4), pp. 1-7. [Online]. Available: https://www.bebr.ufl.edu/sites/default/files/Research%20Reports/floridafocus4_4_2008_0.pdf.