



ISSN NO. 2320-5407

Journal Homepage: -www.journalijar.com

INTERNATIONAL JOURNAL OF ADVANCED RESEARCH (IJAR)

Article DOI:10.21474/IJAR01/8101
DOI URL: <http://dx.doi.org/10.21474/IJAR01/8101>



INTERNATIONAL JOURNAL OF
ADVANCED RESEARCH (IJAR)
ISSN 2320-5407
Journal Homepage: <http://www.journalijar.com>
Journal DOI:10.21474/IJAR01

RESEARCH ARTICLE

ADVANCED AND EFFICIENT MAC PROTOCOL FOR MOBILE AD-HOC NETWORK.

Rahul Mukherjee.

Assistant Professor, Electronics & Telecommunication Engineering Department, Rungta College of Engineering & Technology (RCET), Bilhailai, India.

Manuscript Info

Manuscript History

Received: 12 September 2018
Final Accepted: 14 October 2018
Published: November 2018

Keywords:

Manet, 802.11 mac, dcf, csma.

Abstract

Mobile Ad-hoc Network (MANET) is an autonomous system of mobile nodes connected by wireless links. The nodes are free to move about and organize themselves into a network. These nodes change position frequently. To accommodate the changing topology special routing algorithms are needed. The Media Access Control (MAC) data communication protocol sub-layer provides addressing and channel access control mechanisms that make it possible for network nodes to access common wireless channel through distributed coordination function (DCF). This work proposes a new power controlled MAC protocol based on IEEE 802.11. Network Simulator 2 (NS2) has been used for simulation. It saves considerable amount of power and achieves the performance matching with that of IEEE 802.11

Copy Right, IJAR, 2018,. All rights reserved.

Introduction:-

A Mobile Ad-hoc network (MANET) is a network formed and functioning without any established infrastructure or centralized administration and consists of mobile nodes that use a wireless interface to communicate with each other. These mobile nodes serve as both hosts and routers so they can forward packets on behalf of each other. Hence the mobile nodes are able to communicate beyond their transmission range by supporting multihop communication. Mobile nodes can move freely, and organize themselves randomly i.e. each host can dynamically enter and leave the network. Thus, the network topology may change frequently and rapidly. This means that the network has to adapt itself to the current topology. A MANET may either work as self-configured stand-alone network or may be connected to the Internet through gateway nodes.

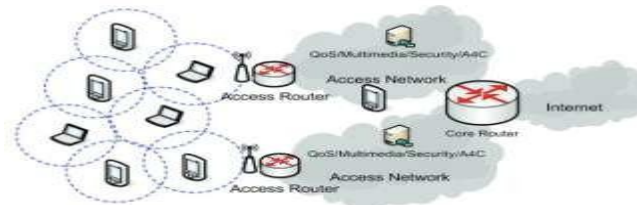

Figure1:-Ad-hoc Wireless Network

Corresponding Author:-Rahul Mukherjee.

Address:-Assistant Professor, Electronics & Telecommunication Engineering Department, Rungta College of Engineering & Technology (RCET), Bilhailai, India

Hidden and Exposed Node Issue:-

The transmission range of stations in wireless network is limited by the transmission power; therefore, all the station in a LAN cannot listen to each other. This means that normal carrier sense mechanism which assumes that all stations can listen to each other, fails. In particular, this gives rise to hidden node and exposed node problem. Consider stations A, B, C and D as shown in figure.

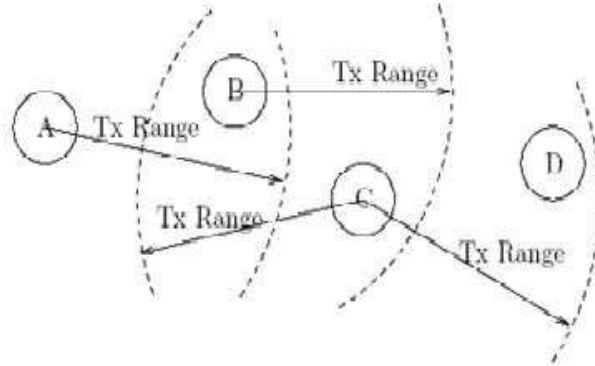

Figure 2:-Hidden & Exposed node problem

CSMA/CA:-

The most important part of a MAC protocol is Channel Access Mechanism. The channel access mechanism is way of regulating the use of physical channel among the stations present in the network. It specifies when a station can send or receive data on the channel.

CSMA/CA (Carrier Sense Multiple Access) is derived from CSMA/CD (Collision Detection) which is the channel access mechanism used in wired Ethernets. Since the transmission range of wireless stations is limited, collision cannot be detected directly. This protocols tries to avoid the collision. On arrival of a data packet from LLC, a station senses the channel before transmission and if found idle, starts transmission. If another transmission is going on, the station waits for the length of current transmission, and starts contention. Since the contention is a random time, each station get statistically equal chance to win the contention.

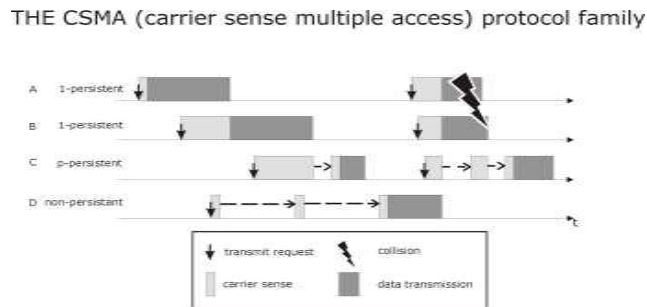

Figure 3:-CSMA Channel Access Mechanism

CSMA/CA is asynchronous mechanism for medium access and does not provide any bandwidth guarantee. It's a best effort service and is suited for packetized applications like TCP/IP. It adapts quite well to the variable traffic conditions and is quite robust against interference.

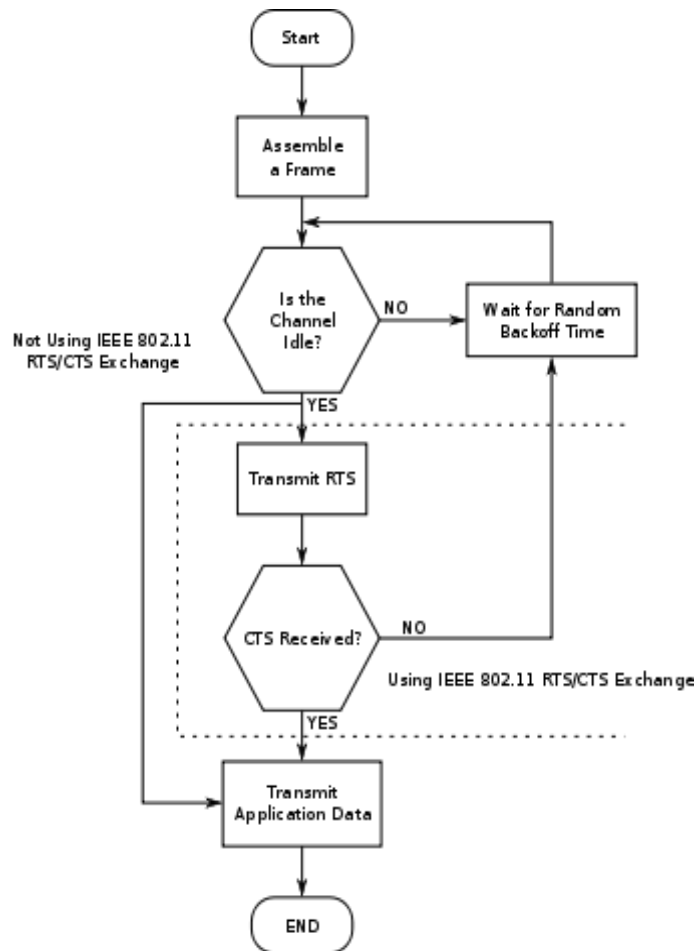

Figure 4:-Flow chart of CSMA/CA

Classification Of Mac Protocol

MAC protocols for ad-hoc wireless networks can be classified into several categories based on various criteria such as initiation approach, time synchronization, and reservation approach. Ad-hoc Network MAC protocols are classified in three types;

1. Contention based protocols.
2. Contention based protocols with reservation mechanism.
3. Contention based protocols with scheduling mechanism.
4. Contention Based Protocols

These protocols follow a contention based channel access policy. A node doesn't make any resource reservation in priori. Whenever it receives a packet to be transmitted, it contends with other nodes for access to the shared channel. These are further divided into two types;

1. Sender initiated protocols
2. Receiver initiated protocols

Contention Based Protocol with Reservation Mechanisms:-

Ad-hoc wireless networks sometimes may need to support real time traffic, which requires QoS guarantees to be provided. In order to support such traffic, certain protocols have mechanism for reserving bandwidth in priori. These protocols are classified into two types;

1. Synchronous protocols
2. Asynchronous protocols

Contention Based Protocol with Scheduling Mechanisms:-

These protocols focus on packet scheduling at nodes, and also scheduling nodes for access to the channel. Node scheduling is done in a manner so that all nodes are treated fairly. Scheduling based scheme are also used for enforcing priorities among flows whose packets are queued at nodes.

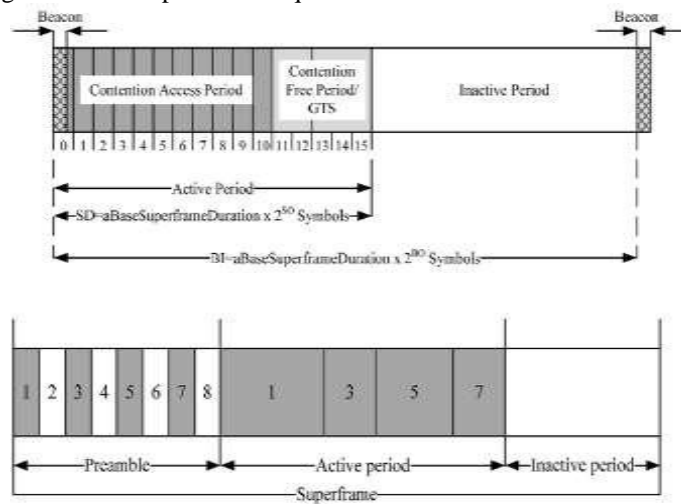

Figure 5:-MAC Architecture

Ieee 802.11 Operation:-

The IEEE 802.11 MAC offers two kinds of medium access methods, namely Distributed Coordination Function (DCF), and Point Coordination Function (PCF). DCF is the basic access method in 802.11 and requires no infrastructure.

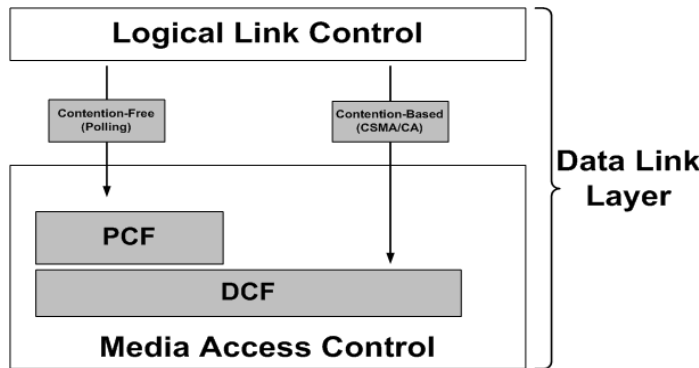

Figure 6:-DCF-PCF Coordination

The IEEE 802.11 MAC offers DCF, and PCF. DCF requires no infrastructure. When wireless stations are within transmit range of each other, they form a Basic Service Set (BSS), and can communicate to each other using DCF. If the BSS contains only two stations, it is called Independent Basic Service Set (IBSS). Many BSSs may be connected by a Distribution System (DS) to form an Extended Service (ESS). An access point (AP) is the station that prov access to DS services.

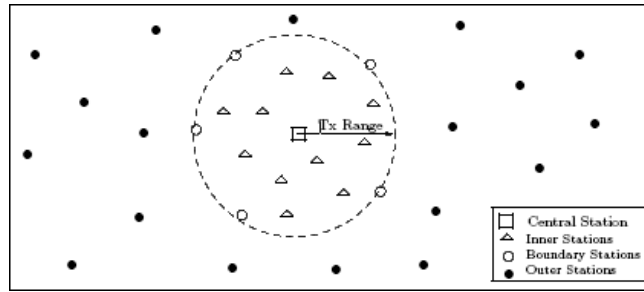

Figure 7:-Multi-hop Scenario

Consider a multi-hop centralized scenario, as shown in the figure. For convenience, the stations inside the network are classified into following categories:

Central station:-

is the central controlling station. Most of the traffic in the network is directed towards it.

Inner stations:-

are within one hop boundary of the central station.

Boundary stations :

are at one hop boundary of the central station. These stations act as relaying stations for the stations outside the reach of central node. Outer stations are outside the communication range of central node.

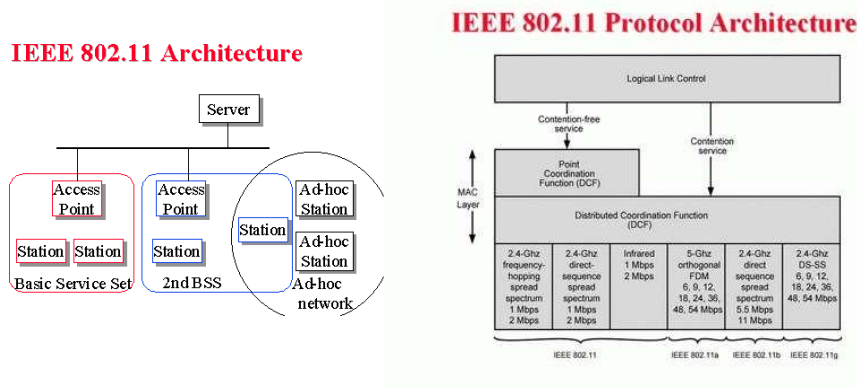

Figure 8:-IEEE 802.11 Protocol Architecture

Ieee 802.11 Scheme Specification:-

IEEE 802.11 specifies two medium access control protocols, PCF (Point Coordination Function) and DCF (Distributed Coordination Function). PCF is a centralized scheme, whereas DCF is a fully distributed scheme. We consider DCF in this paper.

Transmission range :-

When a node is within transmission range of a sender node, it can receive and correctly decode packets from the sender node. In our simulations, the transmission range is 250 m when using the highest transmit power level.

Carrier sensing range:-

Nodes in the carrier sensing range can sense the sender’s transmission. Carrier sensing range is typically larger than the transmission range, for instance, two times larger than the transmission range. In our simulations, the carrier sensing range is 550 m when using the highest power level. Note that the carrier sensing range and transmission range depend on the transmit power level.

Carrier sensing zone :

When a node is within the carrier sensing zone, it can sense the signal but cannot decode it correctly. Note that, as per our definition here, the carrier sensing zone does not include transmission range. Nodes in the transmission range can indeed sense the transmission, but they can also decode it correctly. Therefore, these nodes will not be in the carrier sensing zone as per our definition. The carrier sensing zone is between 250 m and 550 m with the highest power level in our simulation.

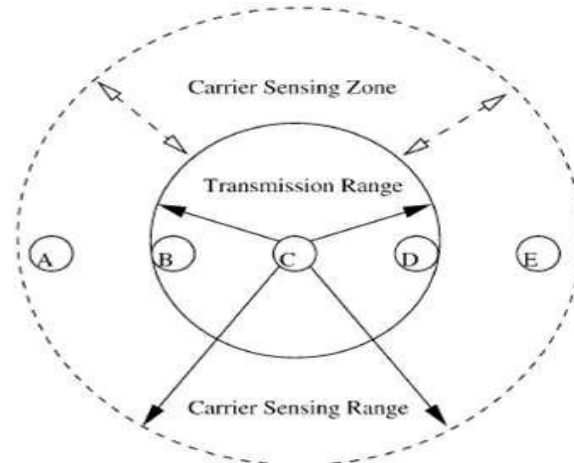

Figure 9:-Carrier Sensing

Mac Sub Layer InIeee 802.11:-

The IEEE standard 802.11 specifies the most famous family of WLANs in which many products are already available. This means that the standard specifies the physical and medium access layer adapted to the special requirements of wireless LANs, but offers the same interface as the others to higher layers to maintain interoperability.

System Architecture:-

The basic service set (BSS) is the fundamental building block of the IEEE 802.11 architecture. A BSS is defined as a group of stations that are under the direct control of a single coordination function (i.e., a DCF or PCF) which is defined below. The geographical area covered by the BSS is known as the basic service area (BSA), which is analogous to a cell in a cellular communications network.

Conceptually, all stations in a BSS can communicate directly with all other stations in a BSS. However, transmission medium degradations due to multipath fading, or interference from nearby BSSs reusing the same physical-layer characteristics (e.g., frequency and spreading code, or hopping pattern), can cause some stations to appear hidden from other stations. An ad hoc network is a deliberate grouping of stations into a single BSS for the purposes of internetworked communications without the aid of an infrastructure network. Given figure is an illustration of an independent BSS (IBSS), which is the formal name of an ad hoc network in the IEEE 802.11 standard. Any station can establish a direct communications session with any other station in the BSS, without the requirement of channeling all traffic through a centralized access point (AP).

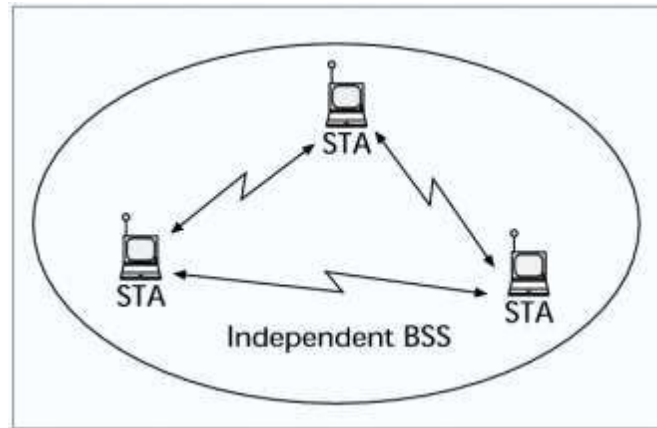

Figure 10:-System Architecture of an Ad-hoc network

In contrast to the ad hoc network, infrastructure networks are established to provide wireless users with specific services and range extension. Infrastructure networks in the context of IEEE 802.11 are established using APs. The AP supports range extension by providing the integration points necessary for network connectivity between multiple BSSs, thus forming an extended service set (ESS). The ESS has the appearance of one large BSS to the logical link control (LLC) sub layer of each station (STA). The ESS consists of multiple BSSs that are integrated together using a common distribution system (DS). The DS can be thought of as a backbone network that is responsible for MAC-level transport of MAC service data units (MSDUs).

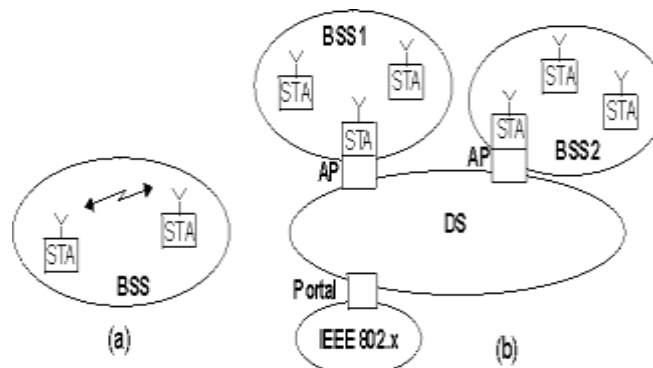

Figure 11:-Example of infrastructure network

Dcf Operation

The DCF is the fundamental access method used to support asynchronous data transfer on a best effort basis. The DCF is based on CSMA/CA. The carrier sense is performed at both the air interface, referred to as physical carrier sensing, and at the MAC sub layer, referred to as virtual carrier sensing. Physical carrier sensing detects presence of

Inter frame Spacing:-

IFS is the time interval between frames. IEEE 802.11 defines four IFSs – SIFS (short inter frame space), PIFS (PCF inter frame space), DIFS (DCF inter frame space), and EIFS (extended inter frame space). The IFSs provide priority levels for accessing the channel. The SIFS is the shortest of the inter frame spaces and is used after RTS, CTS, and DATA frames to give the highest priority to CTS, DATA and ACK, respectively. In DCF, when the channel is idle, a node waits for the DIFS duration before transmitting any packet.

In figure, nodes in transmission range correctly set their NAVs when receiving RTS or CTS. However, since nodes in the carrier sensing zone cannot decode the packet, they do not know the duration of the packet transmission. To prevent a collision with the ACK reception at the source node, when nodes detect a transmission and cannot decode it, they set their NAVs for the EIFS duration. The main purpose of the EIFS is to provide enough time for a source node to receive the ACK frame, so the duration of EIFS is longer than that of an ACK transmission. As per IEEE

802.11, the EIFS is obtained using the SIFS, the DIFS, and the length of time to transmit an ACK frame at the physical layer's lowest mandatory rate, as the following equation :

$$EIFS = SIFS + DIFS + [(8 \cdot ACKsize) + Preamble Length + PLCP Header Length] / Bit Rate$$

other users by analyzing the activity in the channel through where ACK size is the length (in bytes) of an ACK frame, and the received signal strength. Bit Rate is the physical layer's lowest mandatory rate. Preamble length is 144 bits and PLCP Header Length is 48 bits. Using a 1 Mbps channel bit rate, EIFS is equal to 364 μs. information in the header of RTS, CTS and ACK frames. The stations in BSS use this information to adjust their Network Allocation Vector (NAV), which indicates amount of time that must elapse until the current transmission is complete and the channel can be sampled again for idle status.

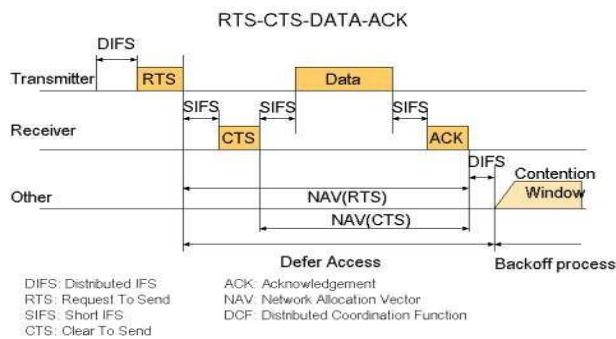

Figure 13:-NAV duration in transmission range and carrier sensing zone

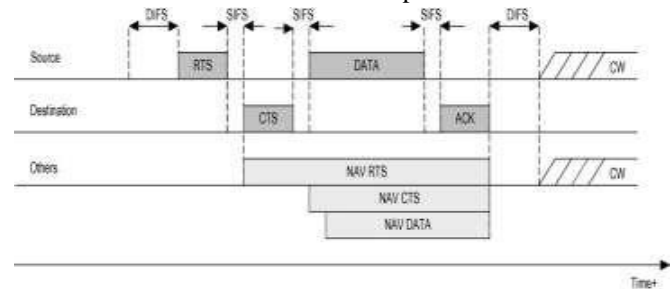

Figure 12:-DCF access using RTS/CTS

Basic Power Control Protocol:-

Here nodes A and B send RTS and CTS, respectively, with the highest power level so that node C receives the CTS and defers its transmission. By using a lower power for DATA and ACK packets, nodes can conserve energy.

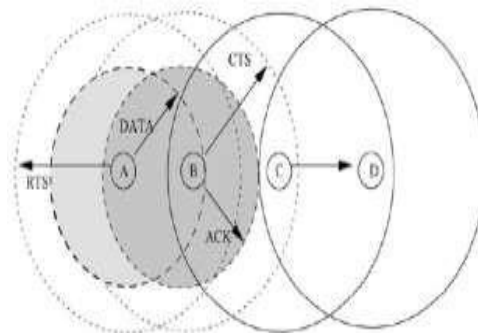

Figure 14:-Basic Scheme.

In the Basic scheme, the RTS-CTS handshake is used to decide the transmission power for subsequent DATA and ACK packets. This can be done in two different ways as described below. Let p_{max} denote the maximum possible transmit power level.

Suppose that node A wants to send a packet to node B. Node A transmits the RTS at power level p_{max}. When B receives the RTS from A with signal level p_r, B can calculate the minimum necessary transmission power level, p_{desired}, for the DATA packet based on received power level p_r, the transmitted power level, p_{max}, and noise level at the receiver B.

We can borrow the procedure for estimating p_{desired} from. This procedure determines p_{desired} taking into account the current noise level at node B. Node B then specifies p_{desired} in its CTS to node A. After receiving CTS, node A

sends DATA using power level $p_{desired}$. Since the signal-to-noise ratio at the receiver B is taken into consideration, this method can be accurate in estimating the appropriate transmit power level for DATA.

In the second alternative, when a destination node receives an RTS, it responds by sending a CTS as usual (at power level p_{max}). When the source node receives the CTS, it calculates $p_{desired}$ based on received power level, p_r , and transmitted power level (p_{max}), as

$$P_{ded} = p_{max}/p_r \cdot R_{xthresh} \cdot c,$$

where $R_{xthresh}$ is the minimum necessary received signal strength and c is a constant. We set c equal to 1 in our simulations. Then, the source transmits DATA using a power level equal to $p_{desired}$. Similarly, the transmit power for the ACK transmission is determined when the destination receives the RTS.

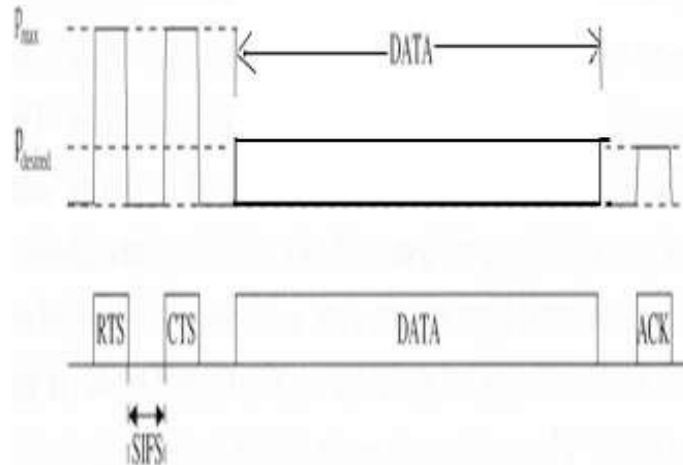

Figure 15:-Basic Power Control Protocol.

Deficiency Of The Basic Protocol:-

In the Basic scheme, RTS and CTS are sent using p_{max} , and DATA and ACK packets are sent using the minimum necessary power to reach the destination. When the neighbour nodes receive an RTS or CTS, they set their NAVs for the duration of the DATA-ACK transmission. When D and E transmit the RTS and CTS, respectively, B and C receive the RTS, and F and G receive the CTS, so these nodes will defer their transmissions for the duration of the D-E transmission. Node A is in the carrier sensing zone of D (when D transmits at p_{max}) so it will only sense the signals and cannot decode the packets correctly. Node A will set its NAV for EIFS duration when it senses the RTS transmission from D. Similarly, node H will set its NAV for EIFS duration following CTS transmission from E.

When transmit power control is not used, the carrier sensing zone is the same for RTS-CTS and DATA-ACK since all packets are sent using the same power level. However, in Basic, when a source and destination pair decides to reduce the transmit power for DATA-ACK, the transmission range for DATA-ACK is smaller than that of RTS-CTS; similarly, the carrier sensing zone for DATA-ACK is also smaller than that of RTS-CTS.

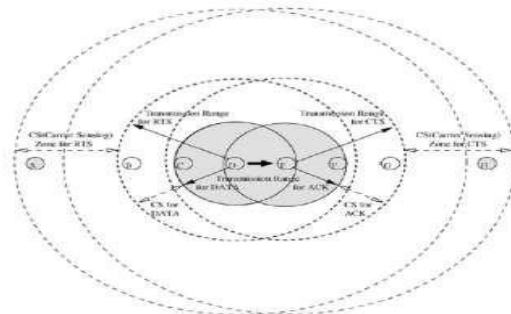

Figure 16:-Basic Scheme

Proposed Power Control Mac Protocol:-

Proposed power control MAC (PCM) is similar to the Basic scheme in that it uses power level p_{max} for RTS–CTS and the minimum necessary transmit power for DATA–ACK transmissions. We now describe the procedure used in PCM.

Source and destination nodes transmit the RTS and CTS using p_{max} . Nodes in the carrier sensing zone set their NAVs for EIFS duration when they sense the signal and cannot decode it correctly.

The source node may transmit DATA using a lower power level, similar to the BASIC scheme.

To avoid a potential collision with the ACK (as discussed earlier), the source node transmits DATA at the power level p_{max} , periodically, for just enough time so that nodes in the carrier sensing zone can sense it.

The destination node transmits an ACK using the minimum required power to reach the source node, similar to the BASIC scheme.

Figure shows how the transmit power level changes during the sequence of an RTS–CTS–DATA–ACK transmission. After the RTS–CTS handshake using p_{max} , suppose the source and destination nodes decide to use power level p_1 for DATA and ACK. Then, the source will transmit DATA using p_1 and periodically use p_{max} . The destination uses p_1 for ACK transmission.

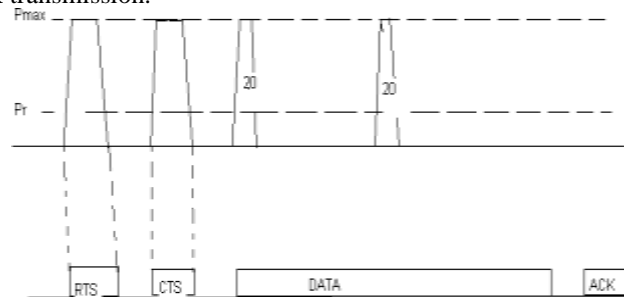

Figure 17:-PCM periodically increases

The main difference between PCM and the Basic scheme is that PCM periodically increases the transmit power to p_{max} during the DATA packet transmission. With this change, nodes that can potentially interfere with the reception of ACK at the sender will periodically sense the channel as busy, and defer their own transmission.

Accordingly, $15 \mu s$ should be adequate for carrier sensing, and time required to increase output power (power on) from 10% to 90% of maximum power (or power-down from 90% to 10% of maximum power) should be less than $2 \mu s$. Thus, we believe $20 \mu s$ should be enough to power up ($2 \mu s$), sense the signal ($15 \mu s$), and power down ($2 \mu s$). In our simulation, EIFS duration is set to $212 \mu s$ using a 2 Mbps

bit rate. In PCM, a node transmits DATA at p_{max} every $190 \mu s$ for a $20 \mu s$ duration. Thus, the interval between the transmissions at p_{max} is $210 \mu s$, which is shorter than EIFS duration. A source node starts transmitting DATA at p_{max} for $20 \mu s$ and reduces the transmit power to a power level adequate for the given transmission for $190 \mu s$. Then, it repeats this process during DATA transmission. The node also transmits DATA at p_{max} for the last $20 \mu s$ of the transmission.

With the above simple modification, PCM overcomes the problem of the BASIC scheme and can achieve efficiency comparable to 802.11, but uses less energy.

The proposed power control protocol is modified such that in this the Data and ACK is transmitted at lower power level but after a certain duration it is transmitted at higher power level for a very fraction of time, in order to make the neighboring nodes understand that transmission is going on and they should restrict their transmission during that period so that collision does not take place hence saving power consumption.

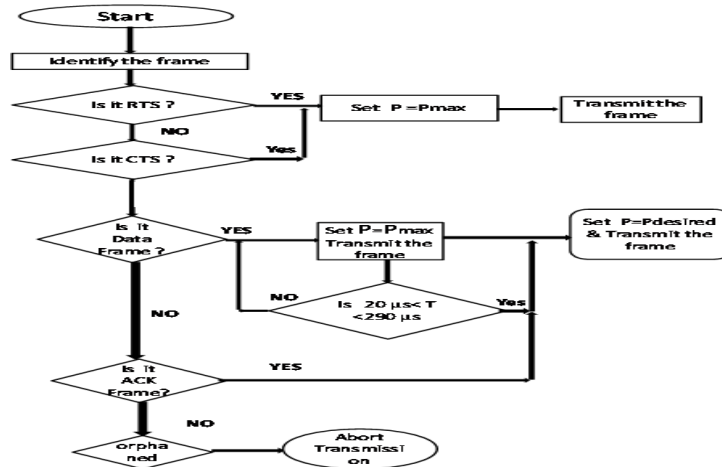
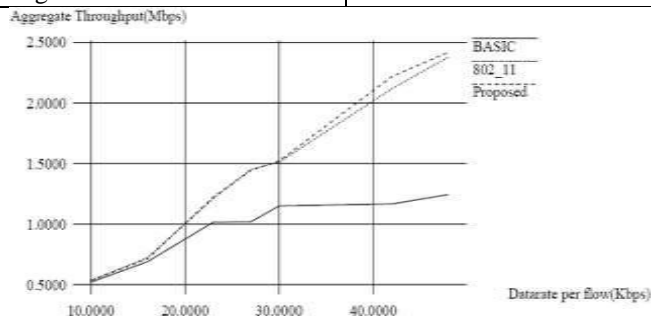

Figure 18:-Flow chart of Proposed Protocol

Simulation Results:-

The given table shows all the different parameters taken into account for conducting the simulation in NS-2 atmosphere. In this table the values of all the different parameters are shown, using which the simulation for aggregate throughput and total data delivered per joule in accordance with Data rate per flow and Packet size is calculated for all three schemes namely, BASIC, 802.11 and Proposed protocol's.

| Parameters | Values |
|-------------------------|-------------------------|
| Number of nodes | 50 |
| Simulation Area(m) | 800x800 |
| Topology | Random |
| Transmission range | 50,100,150,200,250 |
| Radio Propagation model | Shadowing |
| Traffic model | CBR, TCP |
| Packet Size | 256,512,1024 bytes |
| Simulation times | 150 seconds,300 seconds |
| Bandwidth | 2 Mbps |
| Routing | DSR |



A. Simulation Result for Aggregate Throughput vs Data Rate Per Flow

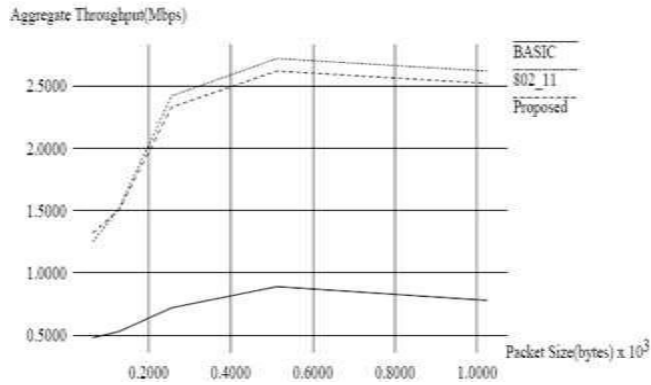

B. Simulation Result for Data Delivered per Joule vs Data rate per flow

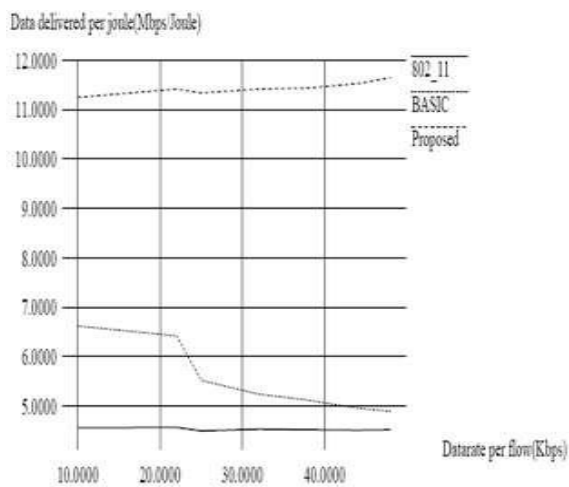

C. Simulation Result for Data Delivered per joule vs Packet Size

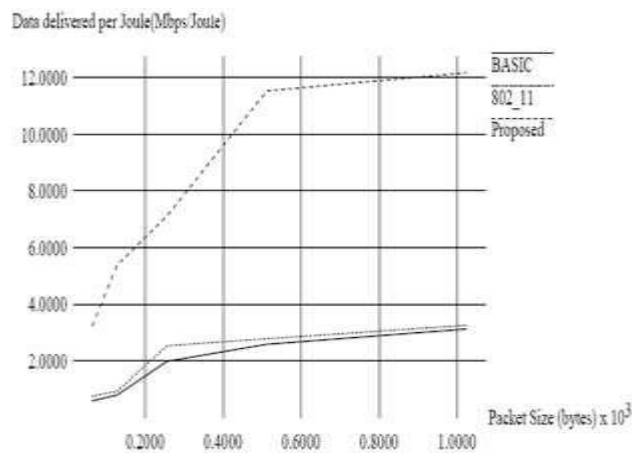

D. Simulation Result for Aggregate Throughput vs Packet Size

Conclusion:-

It is shown that the Basic scheme increases collisions and retransmissions, which can result in more energy consumption and throughput degradation. Hence, the proposed protocol is more efficient than Basic scheme and 802.11 yielding better throughput with much less power consumption, hence yielding better performance compared to the rest protocols.

Suggestion For Future Work:-

We have shown the throughput of proposed protocol comparable to 802.11 with less power consumption for random topology ad hoc network.

In future the same power consumption scheme will be conducted for grid topology.

One possible approach to the mobile ad hoc network power control scheme is that, it is only applied to the Random topology ad hoc scenario but it can also be made applicable for Grid Topology power control scheme without degrading the network throughput. Where the nodes will be placed sequentially in a proper manner i.e, in an arranged fashion.

References:-

1. Awerbunch,D. Holmer, and H. Rubens .The medium time metric: High throughput route selection in multi-rate adhoc wireless network.
2. Ruay-Shiung Chang and Shing-JiuanLeu, January 2006, "Long-lived Path Routing With Received Signal Strength for Ad Hoc Networks", IEEE International Symposium on Wireless Pervasive Computing.
3. R. Wattenhofer, L. Li, P. Bahl and Y.-M. Wang, Distributed topology control for power efficient operation in multihop wireless ad hoc networks, Vol. 3 pp. 1388–1397 (April 2001).
4. N. Poojary, S.V. Krishnamurthy and S. Dao, Medium access control in a network of ad hoc mobile nodes with heterogeneous power capabilities, in: Proc. IEEE International Conference on Communications (ICC 2001), Vol. 3 pp. 872–877 (2001).
5. M.K.Marina and S.R.Das, 2001, "On-Demand Multipath distance vector routing in ad hoc Networks" in: Proceedings of 9th IEEE International Conference on Network Protocols (ICNP).
6. Performance analysis of AODV,DSDV AND DSR in MANETS, International Journal of Distributed and Parallel Systems (IJDPS) Vol.2, No.6, November 2011
7. Geethajayakumar and G Gopinath – —Performance comparison of Two On- demand routing protocols for Ad-hoc Networks based on random way point mobility model.¶ – Department of Computer Science, Bharathidasan University, Trichirapalli- 620 023, India.