



Journal Homepage: - www.journalijar.com
**INTERNATIONAL JOURNAL OF
 ADVANCED RESEARCH (IJAR)**

Article DOI: 10.21474/IJAR01/8382
 DOI URL: <http://dx.doi.org/10.21474/IJAR01/8382>



RESEARCH ARTICLE

VALIDATION OF THE KUNDT TUBE DEVICE MADE FOR THE MEASUREMENT OF ABSORPTION COEFFICIENT AND THE ACOUSTIC IMPEDANCE OF SOME LOCAL CONSTRUCTION MATERIALS IN BENIN.

Houngan C. Aristide¹, Djikou m. Sylvain¹, Agbomahenan Macaire¹, Kiki Gratien Jesugo Dieudonné², Anjorin Malahimi², Vianou Antoine³ and Degan Gérard³.

1. Laboratory of Thermophysical Characterization of Materials and Energy Appropriation (Labo-CTMAE) of the Polytechnic School of Abomey-Calavi (EPAC), 01 BP 2009, Cotonou, Benin.
2. LARPET/ ENSET / Lokossa / Unstim Multidisciplinary Research Laboratory Of Technical Education BP133, Lokossa, Cotonou, Benin.
3. Laboratory of Energetics and Applied Mechanics (LEMA) of the EPAC, 01 BP 2009, Cotonou, Benin.

Manuscript Info

Manuscript History

Received: 12 November 2018

Final Accepted: 14 December 2018

Published: January 2019

Keywords:

Kundt tube; acoustic absorption coefficient, acoustic impedance, material; good performance of the tube.

Abstract

Knowing the acoustic properties (acoustic absorption coefficient and impedance) of the local materials used in the construction of buildings in Benin is a crucial issue for the acoustic comfort of the occupants. However, these properties are not available for each material and they can vary significantly depending on the consistency density and general shape of material. One of the most important and frequently used acoustic properties for a material is the absorption coefficient, which is a measure of the sound energy that a material can absorb from an incident sound wave. For the measurement of this parameter, the use of the Kundt tube is often preferred. Thus, we realized a Kundt tube equipped with a single microphone for the characterization of local materials. The validation of this device has been conducted with three materials that are: wool glass, polystyrene and wood varnish. measurements were performed with samples following the octave band on a frequency range from 250 Hz to 2000 Hz and the values obtained were compared with those of the literature. This has allowed us to ensure the good performance of the tube as well as the replicability and the reliability of measurements.

Copy Right, IJAR, 2018,. All rights reserved.

Introduction:-

The perception of sound is of major importance in everyday life. Speaking, listening to music or singing are examples that show how the sounds are essential to our well-being. Noise however can have serious implications on the quality of life of the people who are directly concerned. Sound noise is a physical phenomenon of mechanical origin consisting in a change of pressure (very low), speed vibration or density of fluid, which spreads by gradually changing the state of each element of the environment considered, thereby giving birth to a sound wave [1]. It can be considered as an agent of environmental stress, which can have a negative impact on the daily life, both at work and at home. The health impacts of noise are grave such as deafness or tinnitus, sleep disorders, hypertension, cardiovascular risks or the deterioration of mental health [2], [3]. The demands of the people have therefore

Corresponding Author:-Houngan c. Aristide.

Address:-Laboratory of Thermophysical Characterization of Materials and Energy Appropriation (Labo-CTMAE) of the Polytechnic School of Abomey-Calavi (EPAC), 01 BP 2009, Cotonou, Benin.

increased and noise is generally less well tolerated. In front of such risks, the inability to eliminate noise sources, taking into account the acoustic comfort in buildings is essential for the good of the people. [4]

Solutions for the implementation of the acoustic comfort in a building depend mainly on the envelope of the latter and therefore the materials that are used for its realization. The choice of a set of materials for insulation or acoustic correction is based on the nature of the noise and acoustic comfort required in a specific place. Therefore, it is necessary to know the acoustic characteristics of each material component of the building envelope.

Unfortunately in Benin, the absence of acoustic data on local building materials makes difficult the realization of acoustic comfort in our buildings. It is in this context that we were asked to install a unit of acoustic characterization of local building materials in the laboratory.

Several methods have been developed by the scientists for the determination of these characteristics which used both testing room and measures in a Kundt tube. Reverb tests are relatively complicated and require expensive facilities and samples of large and specialized equipment. The results of this approach may also vary depending on the overall shape of the sample size and mounting condition [5]. To overcome these drawbacks, the use of the Kundt tube is often adopted to measure and compare the relative values of absorption and impedance acoustic of the materials.

The main objective of this work is to evaluate the acoustic performance of a device of Kundt tube for the determination of the coefficient of absorption and impedance of local materials. So, we will seek, specifically, to achieve the Kundt tube device, then to identify the materials testing and finally to proceed with the validation of our device.

Material and method:-

Materials

The Kundt tube is one of the most widely used test in the field of acoustics. It is used to characterize materials in determining the acoustic absorption coefficient, the reflection coefficient and impedance of surface. The method of measure associated with this way to test is described in standard ASTM E 1050 in North America and in the standard ISO 10534-2 for Europe.

The impedance tube is usually cylindrical in shape. It is composed:

1. a rigid and right tube;
2. a door sample intended to accommodate the material under test;
3. a section of measurement where the microphones are fixed so as to have the membrane flush to the tube (for the method of the electronic doublet) or a fixed microphone at the end of a rod moving in the tube (for the method of the single microphone);
4. a speaker for the sound.

Method

This method uses a tube of uniform section, of fixed length (figure 1). The field of standing waves is created by a speaker powered by a sinusoidal signal, generated and then amplified by the string generator BF / amp BF. The acoustic field created in front of the tube formed by the absorbent material is explored through a mobile microphone.

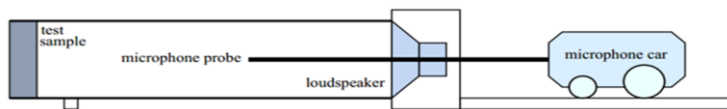

Figure 1:-Kundt tube to single microphone [6].

The method selected for our study is that of the single microphone. This choice is justified by:

1. the reliability of the measurements;
2. the simplicity of the system (no need to make the microphone calibration as in the case of the microphone doublet method);
3. the determination of sought-after tone settings is easier (it does not require the use of the transfer function)

Realization of the Kundt tube

Design of the Kundt tube

Schema of the Kundt tube

The realized Kundt tube is as shown in the figure below.

Figure 2: diagram of realized Kundt tube

The realized Kundt tube consists mainly of:

1. a speaker representing the sound source;
2. a cylindrical tube that serves as a guide for sound waves;
3. a sample carrier intended to accommodate the material under test.
4. a microphone for measurement of pressure along the tube.
5. a rod which wears the microphone and ensures straight line moving in the tube;
6. two brackets to keep the tube in balance.

Choice of materials of the components of the Kundt tube

Table 1:-choice of components of the Kundt tube

Component	Material	Justification
Tube	PVC	Kundt tube has this feature to limit the transmission and absorption of waves ($E_{t \approx E_a \approx 0}$) and in normal incidence. Due to its rigidity and its very low absorption coefficient ($\alpha = 0, 04$ at 1000 Hz [7]), but also its low cost and its wide availability, we choose the PVC pipe.
Sample holder	Ordinary steel	The sample must be placed in a medium that is rigid and impermeable, which removes the transmission and absorption of waves. So the ordinary steel (very low absorption coefficient, $\alpha = 0, 03$ at 1000 Hz [8]) was used.
Microphone stem	Aluminium	The door-microphone must be supported by the sample holder and it must slide easily. That is why we choose a low density material having a very good state of surface after machining: these are the reasons behind the choice of aluminum.

Sizing the Kundt tube

The measuring method is based on the principle that only the flat waves propagate in the tube. This implies a limit frequency. Indeed, from a certain frequency, called cut-off frequency, other types of waves appear and it is no longer possible to separate plane wave from others.

The cut-off frequencies (of minimum and maximum) depend on the length L of the diameter d of the tube, respectively. The smaller the tube is, the higher the cut-off frequency is. Following Dowling, the limit of measurement in high frequency f_{max} is determined by the expression (Dowling et al, 1985) [9]:

$$f_{max} < \frac{c}{1,67d} \tag{1}$$

With:

f_{max} : maximum frequency of cut in Hz;

c: the speed of sound waves in $m.s^{-1}$;

d: the internal diameter of the pipe in m.

As a result, the limit low-frequency measurement is obtained by:

$$f_{min} > \frac{3c}{4L} \tag{2}$$

Where L is the length of the pipe in m.

The frequency f to cover is in the limit:

$$\frac{3c}{4L} < f < \frac{c}{1,67d} \tag{3}$$

For our study, we chose a tube of diameter $d = 0, 1$ m and length $L = 1$ m

Frequency range to be covered will be: $255 \text{ Hz} < f < 2035 \text{ Hz}$.

Realization of the Kundt tube

Mounting of the device

The assembly of the parts constituting the Kundt tube is done as follows:

1. developing of the cylindrical tube into the brackets;
2. setting the speaker at one of the ends of the tube;
3. setting the microphone on the stem;
4. introducing the stem with microphone in the sample carrier;
5. assembling the set (a gate sample, stem and microphone) to the second end of the tube.

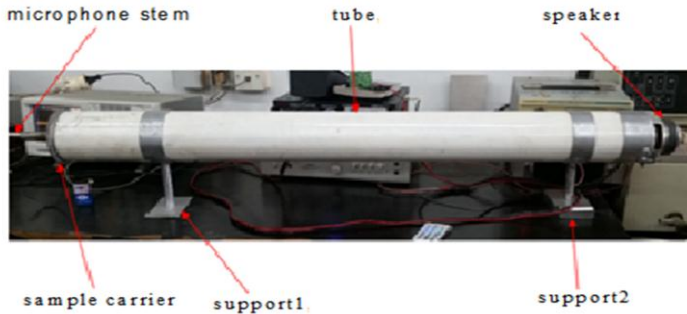

Implementation of the data acquisition unit

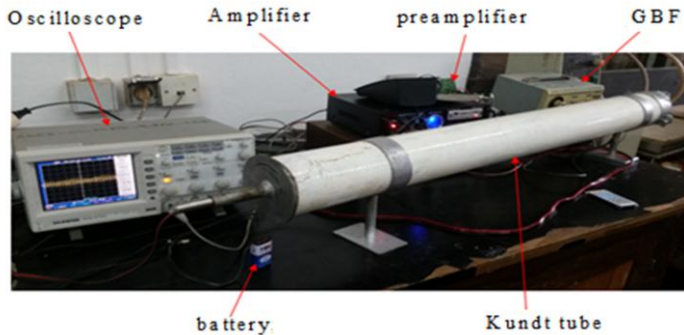

Figure 3:-Measuring bench of the coefficient of absorption and acoustic impedance of materials.

Steps in the data acquisition process include the following:

1. placing a sample of the material to be tested in the sample holder and mounting it in the tube;
2. powering on the analyzer (oscilloscope) frequency and setting it for the octave band measures;
3. connecting the microphone through a pre-amplifier Jack then a direct amplifier at the entrance of the frequency analyzer;
4. connecting the speaker to the low frequency generator already energized for the emission of the sound waves;
5. setting the low frequency generator to produce sine waves on different frequencies of the band of octaves; then starting the measurement by reading maximum and minimum voltage levels on frequency monitor through the displacement of the rod to the microphone in the tube (be careful so as not not to touch the speaker with microphone).

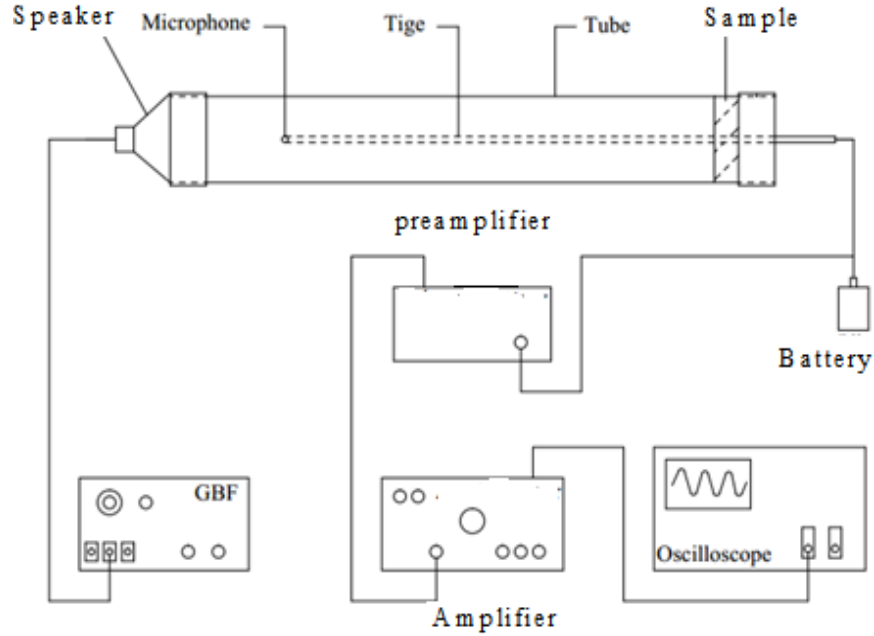

Figure 4:-Diagram of the data acquisition unit.

Choice of materials to be tested

For the validation of the realized Kundt tube, we chose three materials whose acoustic properties are known: glass wool, polystyrene and varnished wood. Made from natural products (sand and recycled glass), glass wool is an insulating material which is usually in the form of a more or less flexible mattress where the air is trapped by intertwined fibres [10], [11]. Glass wool is used for thermal insulation and sound insulation of the buildings for residential or non-residential buildings. Its features also allow it to be used as absorbent for acoustic correction or in protection against fire.

Meanwhile, polystyrene consists of a compact and white foam used most often for thermal insulation and packing. Expanded polystyrene is obtained from polystyrene crystal to which has been added, during polymerisation, an agent of expansion (often water vapour then pentane). From the acoustic point of view, it is a little absorbent material.

As far as wood is concerned, it is a light material which the acoustic insulation properties are not very good. The thick wood structure shows it to be compact and with smooth surface cushions. However, with noise, wood is not a good absorbent material.

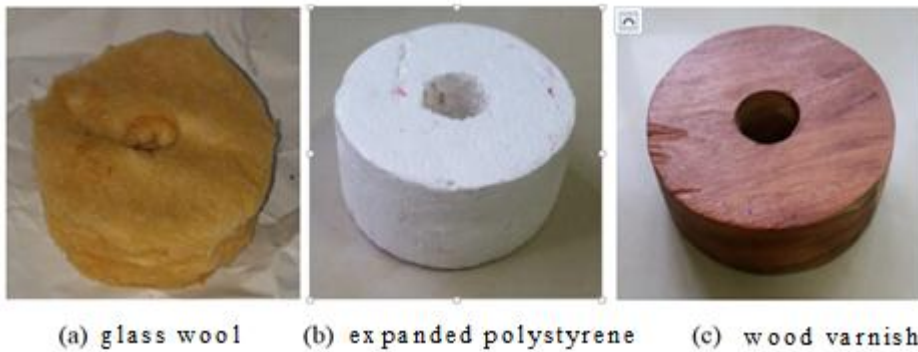

(a) glass wool (b) expanded polystyrene (c) wood varnish

Figure 5:-Samples for validation of the realized Kundt tube.

Results and discussion:-

Results

Validation of measurements of the coefficient of absorption of the samples

Measurement Protocol

First steps on materials with known properties are essential to test the completed device. To do this, we chose different materials: an (01) absorbing material (glass wool); a (01) very little absorbing material (expanded polystyrene) and a (01) reflecting material (varnished wood).

These three (03) materials are sampled as follows:

- sample A: glass wool;
- sample B: polystyrene;
- sample C: varnished wood.

According to the different frequencies of the octave band, the absorption factor of each material is determined and the curve of these coefficients traced. This exercise is to be conducted three (03) times and the curves obtained for each type of material to be superimposed to assess the repeatability of measurements with the realized Kundt tube.

Subsequently, the curve of absorption coefficients measured for each material will be drawn then compared to that of the coefficients obtained in the literature.

Measurement of the absorption coefficients

Prior to the measures of the coefficients of absorption of the samples, the performance of the empty tube is first to be evaluated by measuring its coefficients of absorption without a sample inside. The values obtained are reflected in the table below.

Table 1:-of the empty tube absorption coefficient

Empty tube				
Frequency (Hz)	250	500	1000	2000
U_{max} (mV)	3280	3180	2900	2260
U_{mini} (mV)	100	80	40	20
Absorption coefficient (α)	0,11	0,09	0,05	0,01

After the analysis of the table, we notice that the empty tube absorption coefficients are very low on the selected frequency band. This therefore meets the condition to be the most reflective as possible so that incidental radiation emitted from the speaker is not too much absorbed by the sample holder. This then measures the sample carrier.

The first series of measurement are as follows:

Table 2:-absorption factor of the sample (50 mm)

Sample A (50 mm)				
Frequency (Hz)	250	500	1000	2000
U_{maxi} (mV)	3120	3200	2420	820
U_{mini} (mV)	900	880	660	200
Absorption coefficient (α)	0,69	0,67	0,67	0,63

Table 3:-absorption factor of the sample (25 mm)

Sample A (25 mm)				
Frequency (Hz)	250	500	1000	2000
U_{maxi} (mV)	3260	3240	2780	520
U_{mini} (mV)	920	1080	1020	180
Absorption coefficient (α)	0,68	0,75	0,78	0,76

Table 4:-absorption factor of the sample B

Sample B				
Frequency (Hz)	250	500	1000	2000
U_{maxi} (mV)	3180	3180	3160	1020

$U_{mini} (mV)$	260	500	620	80
Absorption coefficient (α)	0,27	0,46	0,54	0,26

Table 5:-absorption factor of the sample C

Sample C				
Frequency (Hz)	250	500	1000	2000
$U_{maxi} (mV)$	3240	3180	3020	2140
$U_{mini} (mV)$	280	120	60	20
Absorption coefficient (α)	0,29	0,16	0,07	0,03

The measurements are repeated three times for each sample.

Results of the repeatability of measurements

To assess the repeatability of the measurements of the realized tube, we need, for each sample, to superimpose the absorption factor of the three series of measurement curves. This gives the figures below:

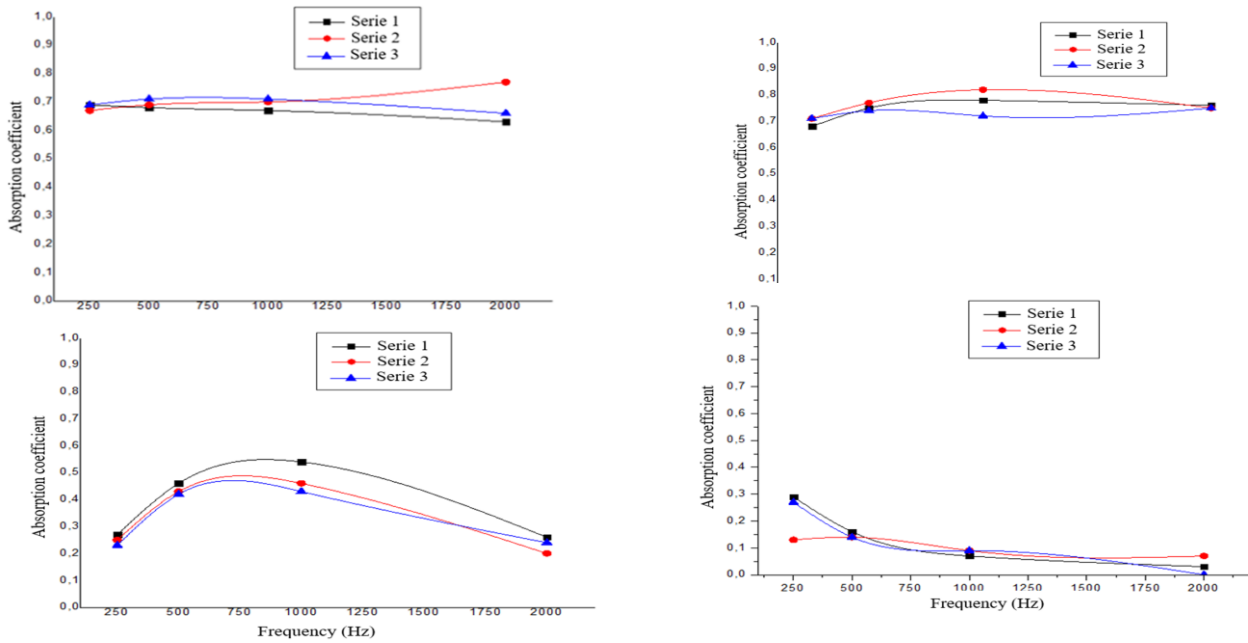

Figure 9:-curve obtained with the B sample repeatability

Figure 10:-curve obtained with the sample C repeatability

The uncertainty of measurement of size M, noted unequal, is a positive parameter that allows us to set an interval of 'likely values' of the magnitude M values in which one has a 95% chance of finding the "real value". This is a 95% confidence interval. The quality of a measure will be that much better when the associated uncertainty will be small. [12]

Designated by $\Delta\alpha$ uncertainties associated with different measurements, we have:

$$\alpha = 1 - \left(\frac{U_{max} - U_{min}}{U_{max} + U_{min}} \right)^2 \tag{4}$$

$$\Delta\alpha = \left| \frac{\partial\alpha}{\partial U_{max}} \right| \Delta U_{max} + \left| \frac{\partial\alpha}{\partial U_{min}} \right| \Delta U_{min} \tag{5}$$

Where:

$$\frac{\partial\alpha}{\partial U_{max}} = \frac{-4U_{min}(U_{max} - U_{min})}{(U_{max} + U_{min})^3} \tag{6}$$

$$\frac{\partial \alpha}{\partial U_{min}} = \frac{4U_{max}(U_{max}-U_{min})}{(U_{max}+U_{min})^3} \tag{7}$$

$$\Delta U_{max} = \sqrt{\frac{\sum_{i=1}^n (U_{max_i} - U_{max})^2}{n(n-1)}} \tag{8}$$

$$\Delta U_{min} = \sqrt{\frac{\sum_{i=1}^n (U_{min_i} - U_{min})^2}{n(n-1)}} \tag{9}$$

With:

α : the absorption factor of the material;

U_{max} : the maximum voltage given by the oscilloscope in mV;

U_{min} : the minimum voltage given by the oscilloscope in mV;

$\Delta\alpha$: measurement uncertainty;

$\frac{\partial \alpha}{\partial U_{max}}$: the partial derivative of the coefficient of absorption compared to the maximum voltage.

$\frac{\partial \alpha}{\partial U_{min}}$: the partial derivative of the coefficient of absorption compared to the minimum voltage;

ΔU_{max} : the uncertainty associated with the measurement of the maximum voltage;

ΔU_{min} : the uncertainty associated with the measurement of the minimum voltage

n: the measurement number (n = 3)

Applying formulas of established higher uncertainty, accuracy on the different measures varies from 0.006 to 0.09.

Trace the curves of validation

According to literature, the coefficients of absorption of the selected materials are distributed in the following tables.

Table 6:-absorption factor of the sample (50 mm) [13], [14]

Sample A (50 mm)					
Frequency (Hz)		250	500	1000	2000
Absorption coefficient (α)	Reference	0,45	0,56	0,59	0,61
	Measured	0,68 ± 0,006	0,69 ± 0,02	0,69 ± 0,05	0,68 ± 0,04

Table 7:-absorption factor of the sample (25 mm) [13], [14]

Sample A (25 mm)					
Frequency (Hz)		250	500	1000	2000
Absorption coefficient (α)	Reference	0,38	0,60	0,64	0,62
	Measured	0,7 ± 0,009	0,75 ± 0,02	0,77 ± 0,05	0,75 ± 0,05

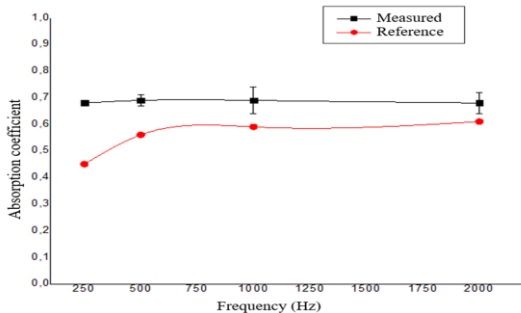

Figure 11:-Curve A (50 mm) sample validation.

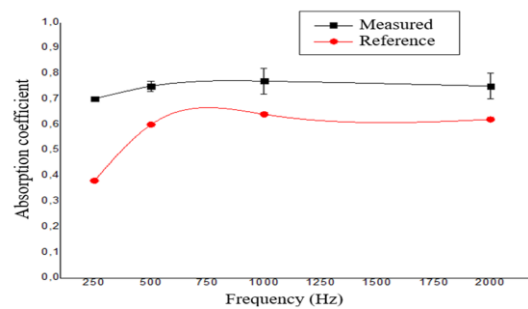

Figure 12:-Curve A (25 mm) sample validation

Table 8:-absorption factor of the sample B [13], [14]

Sample B					
Frequency (Hz)		250	500	1000	2000
Absorption coefficient (α)	Reference	0,1	0,41	0,33	0,21
	Measure	0,25 ± 0,01	0,43 ± 0,01	0,47 ± 0,06	0,23 ± 0,09

Table 9:-absorption factor of the sample C [13], [14]

Sample B					
Frequency (Hz)		250	500	1000	2000

Absorption coefficient (α)	Reference	0,04	0,03	0,03	0,03
	Measure	$0,23 \pm 0,05$	$0,14 \pm 0,02$	$0,08 \pm 0,01$	$0,03 \pm 0,02$

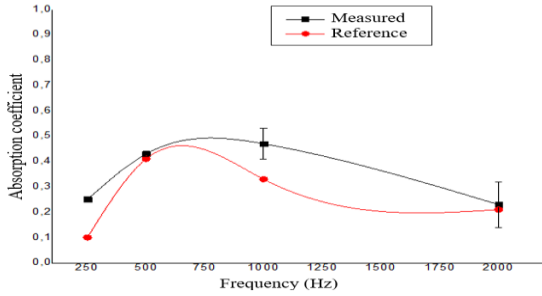

Figure 13:-Validation of the B sample curve

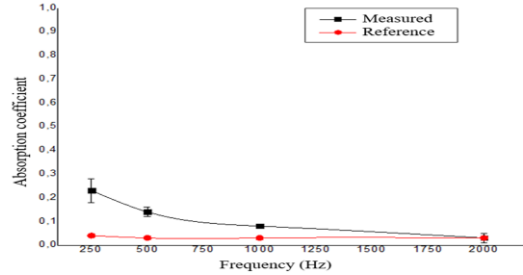

Figure 14:-Validation of the C sample curve

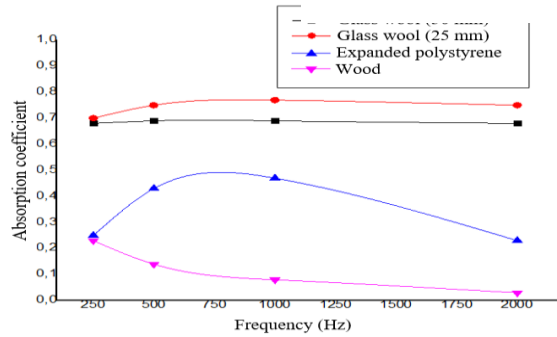

Figure 15:-Curves of validation summary

calculation of the acoustic impedance of the test material

$$Z = \rho c \frac{1+R_0}{1-R_0} \tag{10}$$

With: Z: acoustic impedance of the test material in Ray;

P: density of material $\rho = 1,2 \text{ kg.m}^{-3}$

c: speed of sound ($C = 344 \text{ m.s}^{-1}$);

R_0 : reflection in pressure coefficient.

Tables below provide information on the values of the acoustic impedance of the test materials depending on the frequency.

Table 10:-Acoustic impedance in the sample A (50 mm)

Sample A (50 mm)				
Frequency (Hz)	250	500	1000	2000
Acoustic impedance (Rays)	1455,66	1187,04	1428,58	1458,54

Table 11:-Acoustic impedance of the sample A (25 mm)

Sample A (25 mm)				
Frequency (Hz)	250	500	1000	2000
Acoustic impedance (Rays)	1397,18	888,26	1133,28	1223,04

Table 12:-Acoustic impedance of the sample B

Sample B				
----------	--	--	--	--

Frequency (Hz)	250	500	1000	2000
Acoustic impedance (Rays)	5543,92	2812,30	2328,51	6009,10

Table 13:-Acoustic impedance of the varnish wood

wood varnish				
Frequency (Hz)	250	500	1000	2000
Acoustic impedance (Rays)	6088,23	10927,87	17376,51	44166,06

Discussion:-

A rigorous review of the variability of the results between the three series shows the repeatability of the measurements made with the designed Kundt tube. Indeed, there is a similarity between the curves of the absorption coefficients of glass wool (figure 11 and 12), expanded polystyrene (figure 13) and wood (figure 14). The measurement differences on certain frequencies can be attributed to errors in handling and will not affect the repeatability of measurements.

The performance of the realized Kundt tube is checked by comparing the coefficients of absorption measured for each material to those obtained in the literature. So, by layering the curves obtained with the measured absorption coefficients and those in the literature, the performance of the designed tube can be appreciated. The measures of the coefficients of acoustic absorption in the Kundt tube on a circular sample of wool of glass of 25 mm and 50 mm thickness for a 100 mm diameter have been conducted. Three sets of measures are completed and the curve of the average of the values obtained were plotted and compared to the reference values of the literature. According to these measures, glass wool is an absorbent material since the values tend to 1. However, the curve of the measured values is not identical to the reference curve. We note that the values measured in the range of 250 Hz to 1000 Hz are somewhat remote from the reference values with a maximum absolute error of 0.32 to 250 Hz for wool 0.23 to 250 Hz and 25 mm to 50 mm. Beyond 1000 Hz, the values tend all to be reference values. The observed differences in measures are explained by the non-uniformity of the material, the difficulty to obtain a perfectly flat surface during the implementation of the sample in its container and handling errors. With respect to the expanded polystyrene, the measurements seem to be in line with those of the literature on selected frequency range, with the exception of the frequency of 1000 Hz for which there is a maximum absolute error of 0.17. Unlike glass wool, the varnished wood is a material very little absorbing from the point of view of acoustics. So we should get a 1, and therefore close reflection coefficient, a coefficient of absorption close to 0. Table 7 shows us very close to 0 values as the frequencies increase. These values support the hypothesis that the varnished wood is a reflective material. Reported to the reference values, we find that the measured absorption coefficients are very close to this one except for the frequency of 250 Hz. The maximum absolute error recorded at this frequency is 0.19. The observed errors in this case can be attributed to the direction incident waves by report that components fibre wood, nature of the wood used (literature do not specifically used wood) and handling errors.

Despite the few recorded errors, the realized Kundt tube allows us to categorize very specifically different materials according to their acoustic absorbency (see figure 3.9 below) and with reliable absorption coefficients. The analysis of figure 3.9 allows us to classify glass wool in the category of absorbent materials, polystyrene in the little absorbent materials category and polish wood in the category of the reflective material. [Also, it should be noted that many of the identified errors are obtained at the frequency of 250 Hz which is normally not in the frequency range since the realized Kundt tube is functional on an interval of] 255 Hz; 2035 Hz [15] All this reflects the good performance of the realized Kundt tube.

Conclusion:-

The acoustic comfort of a building depends on the nature of the materials constituting its envelope. It is important to acoustically characterize these building materials. This study therefore sought to establish a mechanism for the determination of the acoustic characteristics of materials (acoustic absorption coefficient and impedance). A bibliographical study of different methods of determination referred us to the choice of one of the most common methods: the Kundt tube method. In this line, a Kundt tube to single microphone was made and its performance has been evaluated through three materials whose acoustic characteristics have been tested and which are: wool glass, polystyrene and wood varnish. Measures of the coefficients of absorption of these materials were conducted with the

device on a frequency ranging from 250 Hz to 2000 Hz, a range allowing their individual categorization. Thus, glass wool has been recognized as an absorbent material, expanded polystyrene as a partially absorbent material and wood varnish as a reflective material. The values obtained were then compared with those of the literature. The results emerging from this comparison allowed us to affirm the good performance of the device and consequently to validate it.

Bibliography:-

1. Martin-Houssart G., Rizk C., 2002. Measure the quality of life in large cities. Study of the INSEE PREMIÈRE, n ° 868, Paris 68 p.
2. Roben O., Berry A., Doutre O., 2014. Measurement of the Porous Materials Absorption Coefficient under Synthetic Diffuse Acoustic Field, 1891-1897.
3. Hounghan C. A., 2003. Phonic characterization of local materials. Abomey-Calavi, EPAC, Memory of DEA Energetic and Environment, 101 p.
4. C.H. Jeong, 2013. Converting Sabine absorption coefficients to random incidence absorption coefficients. J. Acoust. Soc. Am. 133(6), 3951-3962.
5. Wood absorption coefficient 5 http://sacura.chez.com/materiaux/classement_p/absorption_accoust.htm; the 25/04/2018 at 08h5
6. Halliwell R. E., 1983. Inter-laboratory variability of sound absorption measurement, J. Acoust. Soc. Am., 73(3), 880-886.
7. Reinmuth F., 1999. Climatisation et conditionnement d'air modernes par l'exemple. Paris, Edition PYCLIVRES, rue Guilleminot, 296 p
8. Véronique C., 2005. Mechanical, thermal and acoustic properties of a material based on plant particles: experimental approach and theoretical modeling. Lyon, Graduate School: Mechanics, Energetics, Civil and Acoustics Engineering (MEGA), Doctoral Thesis in Civil Engineering, 248 p.
9. Dowling et al, 1985. The absorption of axial acoustic waves by a perforated liner with bias flow.
10. [10] Manuel VAN DAMME, Airborne sound insulation: principles and materials. Acoustical Expert - VK Group.
11. Masateru K., 2014. A new high-frequency impedance tube for measuring sound absorption coefficient and sound transmission loss, 1-12 p.
12. Biansan J-M., Blat S., Nicoules C., Olive J-F., 2017. Notion of errors and uncertainties in experimental sciences. Toulouse, Academy of Toulouse, 10 p.
13. Daniel A. Russell, 1998. Absorption Coefficients and Impedance. Journal of the Acoustical Society of America, 77(4) : 1820-1828 p.
14. Otsuru T. and al., 2009. Ensemble averaged surface normal impedance of material using an in-situ technique : Preliminary study using boundary element method. J. Acoust. Soc. Am., 125(6), 3784-3791 p.
15. Allard J.F. and al., 2003. Impedance measurements around grazing incidence for nonlocally reacting thin porous layers. J. Acoust. Soc. Am., vol. 113 : 1210-1214.