



Journal Homepage: - www.journalijar.com
**INTERNATIONAL JOURNAL OF
 ADVANCED RESEARCH (IJAR)**

Article DOI: 10.21474/IJAR01/9910
 DOI URL: <http://dx.doi.org/10.21474/IJAR01/9910>



RESEARCH ARTICLE

THERMAL SPRAY COATING: A BRIEF UNDERSTANDING.

Sidra Younus¹ and Muhammad Arshad².

1. Institute of Space Technology Islamabad, Pakistan.
2. Comsats University Lahore, Pakistan.

Manuscript Info

Manuscript History

Received: 14 August 2019

Final Accepted: 16 September 2019

Published: October 2019

Keywords: -

Coatings, Thermal spray method, HVOF, Cold Spray, Wire arc spray, Detonation gun.

Abstract

Surface coating applying to critical parts enhances the durability, resistance, wear and endurance of tools, materials and machine components that require desired surface properties like corrosion, erosion and wear resistance. To improve surface properties such as corrosion, adhesion, erosion, and wear functional resistance coating are employed. Currently, plenty of coating methods are applied to achieve the desired functional or decorative properties. The thermal spray coating process is one of the cost-effective and attractive methods to preserve the new machine components from mechanical wear, corrosion, and erosion problems. This paper briefly explains different spray processes, basic principles, advantages, and applications in a simple way.

CopyRight, IJAR, 2019. All rights reserved.

Introduction: -

Coating technology is one of the promising and traditional methods that bring effective results in surfaces of industrial parts by enhancing protection against corrosion and wear problems [1]. Thermal Spray method (TSM) is one of the coating methods used for several past years. Thermal spray is a term adopted to characterize a set of coating processes which uses electrical and combustion methods as thermal energy. It is classified into three major categories 1) flame arc spray 2) electric arc spray 3) plasma spray [2]. Surface engineering done with the thermal spray process uses molten, semi-molten or solid particles onto the prepared substrate of any kind of material [2]. This broadens the use of thermal spraying as surface protection in every sector of the industry. They are distinguished based on coating thickness, particle velocity and temperature etc. Without bringing any changes in the dimensions and part properties of the material, damaged parts can be recoated with TSM after stripping off surface coatings. They apply coatings on the surface without any significant heat transfer. Therefore, a broad range of materials can be coated with TSM and used as a coating material (metallic, ceramic, cermet, and some polymeric) in the form of powder, wire, or rod fed to a heating zone to become molten, and is propelled from there to the surface of substrate material. The production rate and adhesion strength of the thermal spray coating process is very high due to mechanical interlocking as compared to other coating process. Low cost, versatility and high processing speed makes thermal spray coatings usage in almost every field i.e. Aircraft engines, photo chemical industry, bridge, chemical process equipment, automotive system, dies, marine turbines, thermal power plant, power generation equipments.

Corresponding Author:- Sidra Younus.

Address:- Institute of Space Technology Islamabad, Pakistan.

The main advantage of applying coating with thermal spray technology (TSM) is to impart resistance to cavitation erosion, corrosion and wear. Apart from resistance, it provides lubricity, sacrificial wear, chemical resistance electrical conductivity and low or high friction. Thermal spray includes three methods i.e. flame spraying, wire spraying and plasma spraying, they are invented in the same order described. The foremost thermal spray process i.e.flame spraying was invented in 1911 at Switzerland by M.U. Schoop. While, the wire spraying i.e.D-Gun spraying process was invented by R.M. Poorman, H.B. Sargent, and H. Lamprey and patented in 1955 [3]. HVOF was patented in 1958 after its invention by G.H. Smith, J. E Pelton, and R.C. Eschenbach [4]. Lastly, plasma spray method was invented by R.M. Gage, O.H. Nestor, and D.M. Yenni and got patented in 1962) [4]. More simply it is defined as: A process in which, coating material (in the form of powder, wire, or rod) is heated rapidly in a hot gaseous environment (nitrogen or oxygen) and simultaneously projected at a high velocity onto a prepared substrate surface, where it deposits and mechanically interlock with the substrate, to produce the desired thickness of coating.

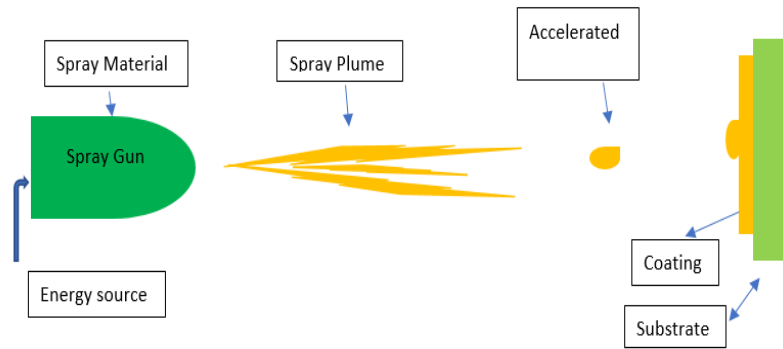

Fig 1.1:-Schematic diagram of thermal spray coating

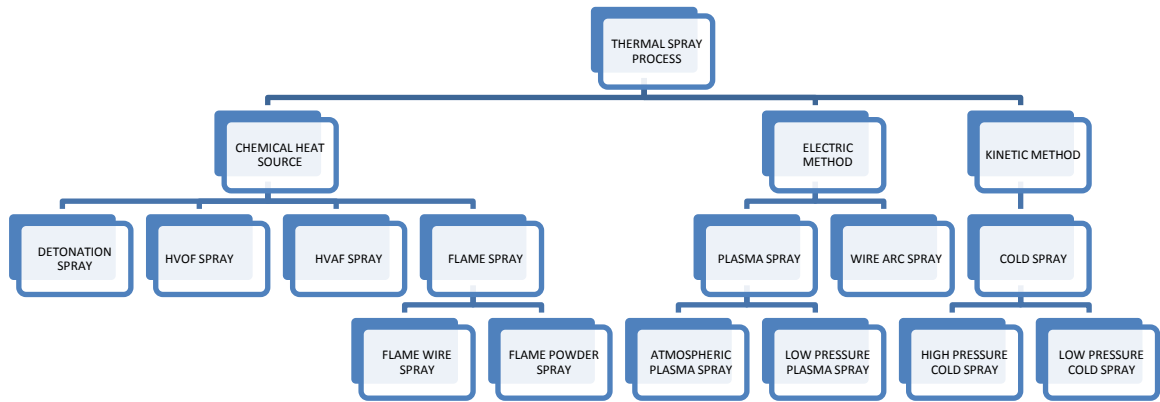

Fig 1.2:-Classification of thermal spray processes

Literature Survey

Based on the temperature and velocity, thermal spray processes can be characterized.[2, 5] Moreover, powder feed rate and deposition efficiency are other distinguishing parameters.

Detonation- Gun Spray (D-Gun spray)

Figure 1.3 shows the schematic diagram of D-gun spray [6]. It is one of the thermal spray processes which has unusually good adhesive strength. This process produces coatings with better mechanical properties, higher density, improved corrosion resistance, better wear resistance, higher bonding, higher hardness and cohesive

strength, ~0% oxidation, thicker coatings, and smoother as-sprayed surfaces. In this process a coating powder and mixture of oxygen (O₂) and acetylene gas (C₂H₂) is introduced through a tubular barrel whose one end is closed while another end is open. The spark plug ignites the gas mixture. Nitrogen gas is used to cover the gas inlets and prevent the back firing. Due to the combustion of the gas mixture, it creates detonation wave (high pressure shock waves), which propagates through the gas stream. The hot gases accelerate the particles to the supersonic velocity. These particles then eject out from the barrel and hit the substrate held by the manipulator stand to form a coating. [2, 5].

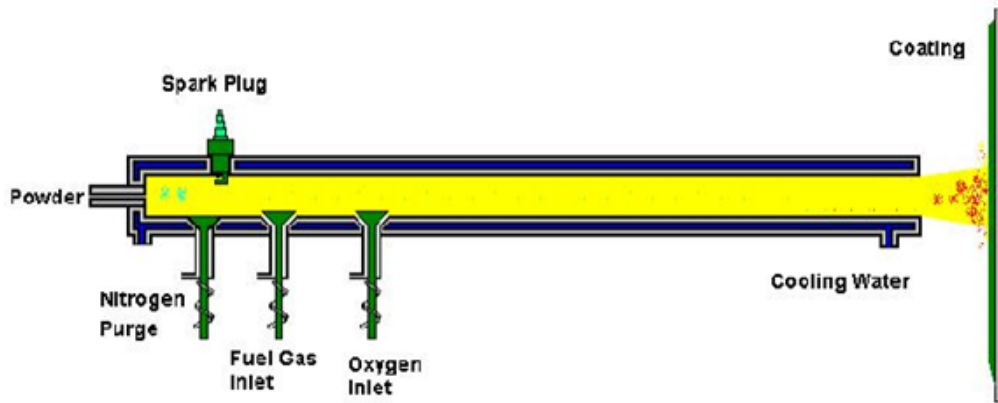

Fig 1.3:-Schematic diagram of Detonation Gun process

The main applications are coatings against abrasion and adhesion (friction) under small load as well as coatings against corrosion. It is commonly used in aeronautic industries specially in advance coating on the driving shaft of a helicopter, steel industries (squeeze rollers, tension rolls), textile industries (thread guides coated with alumina titanium layer, roller, cylinders), and in automobile industries [7].

Flame Spraying

Flame spraying is one of the ancient methods of the thermal spraying processes, characterized by small capital expenditure, high efficiency and better deposition rates, and comparative better ease of operation and less cost of equipment maintenance. Flame spray process uses a combustible gas (propane acetylene, hydrogen and oxygen) as a heat source that melts the coating material, which may be in the form of rod, wire, or powder. Flame spray guns somewhat sprayed manually. The schematics diagram of flame spray process is shown in Fig 1.4.

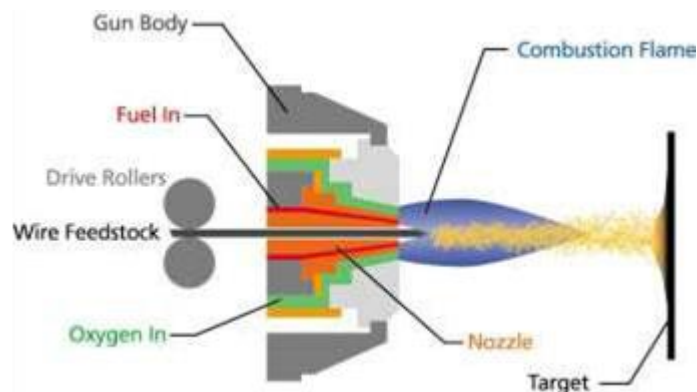

Fig 1.4. Schematics diagram of flame spray process

This device is low cost, easy to operate, very less chances of dust and fumes formation, and simple in design. Bridges, offshore platforms widely use flame spraying method for corrosion protection of structures and machine

parts. It is a favorite choice where a cost effective thermal spray coating is desired and a lower quality can be managed [8].

High Velocity Oxy-Fuel Spray (HVOF)

High velocity oxy-fuel (HVOF) comes under the category of High-velocity flame spraying (HVFS). High-velocity flame spraying (HVAF) includes other techniques as well and they are named as high-pressure high velocity oxygen-fuel (HP-HVOF), high-velocity impact fusion spraying and high-velocity air-fuel (HVAF). The working principle of these systems are almost same in which fuel either gaseous or liquid is combusted with the oxidizer in the combustion chamber. However, they differ in terms of fuel type, oxidizer used, range of particle velocity and temperature. In HVOF, however, temperature is kept low with a combination of high velocity. Deposition takes place efficiently at low temperature level ($\sim 3000\text{K}$) and finally densify the coatings [2].

High velocity and low temperature $\sim 3000\text{K}$ ($2726.85\text{ }^\circ\text{C}$) combination gives HVOF a top priority for the development of tungsten carbide-based cermet coatings with retained carbides in the coatings. This results in a prominent reduction in wear and better mechanical properties of the coatings.

The velocity in this process is approximately 1000m/s and temperature of around 3000K ($2726.85\text{ }^\circ\text{C}$). Different kinds of fuels are used as heat source e.g. hydrogen and kerosene. Hydrocarbons such as ethane, methane and propane are also used as a source of heat. The working principle of HVOF is almost the same as compared to other thermal spray techniques. In these processes, fuel burns with oxidizer (like oxygen) inside the chamber i.e. combustion chamber and generates huge amount of heat and speeds up the coating particles to high velocity. The other dependent parameters of the densified and strongly adhesive coatings to the prepared substrate are traverse speed, substrate quality (e.g. in terms of roughness), standoff distance, type of fuel used, fuel and oxidizer ratio. While in case of WC based coatings, feedstock size and shape greatly affect the final decomposition of the splat, which in return form uniform coating. So, better properties come with the less decarburization and retained WC grains inside the microstructure of the final coating. Low in-flight time and low temperature of 3000K ($2726.85\text{ }^\circ\text{C}$) certainly degrade oxidation level in the final coating, and brings better mechanical interlocking of the splat with the substrate. This better adhesion to the substrate and compact structure reduces porosity level to approx. $<1\%$. Ultimately a better uniformity and homogeneity in the coating microstructure is brought by the uniform heating of primary powder (feedstock material) taken. High rate of micro turbulence in the combustion chamber provides this uniform heating to the feedstock material to be coated. Oxidizer along with this heating provides acceleration to the powder and produces high mechanical and adhesive strength of the coat and the substrate [5].

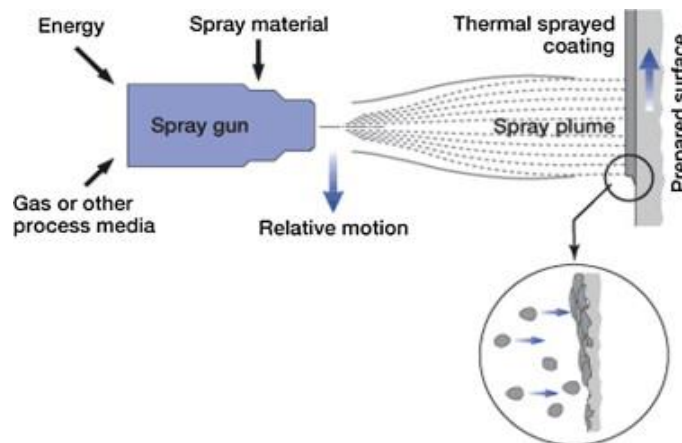

Fig 1.5:-High velocity oxy-fuel (HVOF) Setup

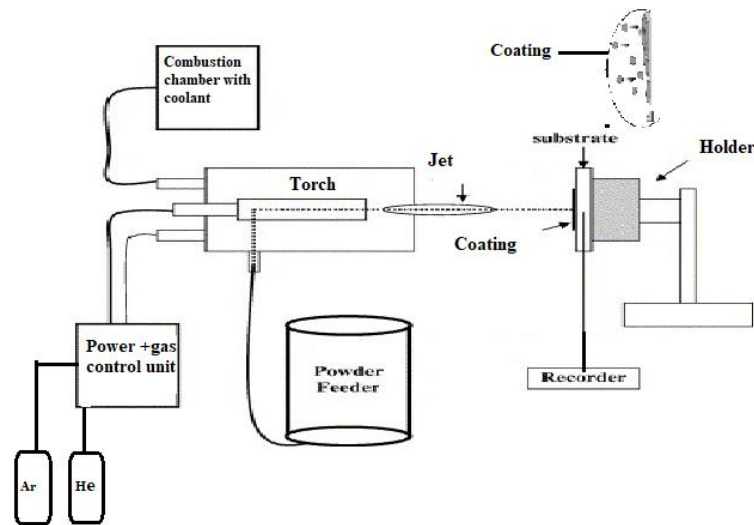

Fig 1.6:-Schematic of HVOF components [5]

Commercially available HVOF systems [6]

HVOF Gun	Manufacturer	Fuel gas	Powder feeding		Coolant (chillers)	Characteristics
			Radial Direction	Axial Direction		
Diamond jet /DJ	Sulzer Metco	Oxygen, air Hydrogen	Radially into the combustion chamber		Water or Air	Convergent / Divergent Nozzle
Jp8000 Or Jp-5000	TAFA	Kerosene Or Oxygen		Barrel	Water	High-Pressure spark
HV-2000	TAFA	Propane, oxygen, Hydrogen	Radially into the combustion chamber		Water	Barrel (straight)
Jet Koat	Deloro Stellite	Propane, oxygen, Hydrogen, propylene	Radially into the combustion chamber		Water	Barrel (straight)
Detonation Gun D-Gun	Praxair Inc	Acetylene or Oxygen	Radially into the combustion chamber		Water	Ignition by Spark

Comparison between different Thermal Spray Methods[6]

Methods	Temp (K)	Velocity (m/s)	Spray Rate (kg/h)	Power	Stand-Off Distance	Porosity
Flame Powder	2200	30	7	25-75	120-250	10-20%
Flame Wire	2800	180	9	50-100	120-250	<1%
HVOF	3100	600-1050	14	100-270	150-300	<1%
D-Gun	3900	910	1	100-270		0.5-2%
Electric Wire Arc	5500	540	16	4-6	50-170	10-20%
Plasma	5500	240	5	80-200	60-130	1-7%

(APS)						
-------	--	--	--	--	--	--

Classification of Thermal Spray Methods Based on Energy Input

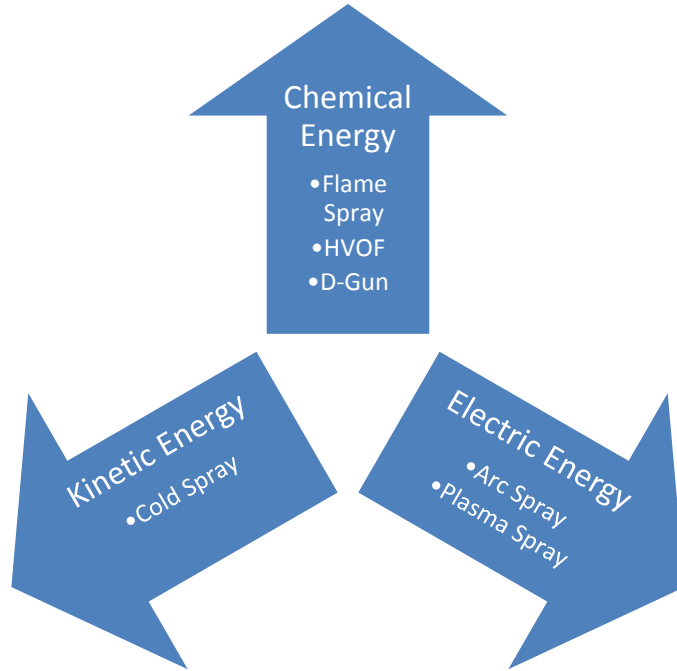

Based on the electrical heat source, the thermal spray process may be classified as:

Plasma Spray

It is one of the most sophisticated and versatile thermal spray methods. In this process, a high-temperature plasma (ionized gas) is produced with the help of direct current (DC electric arc), which acts as the heat source [9]. The schematic diagram of the plasma spray process is shown in Fig.1.7.

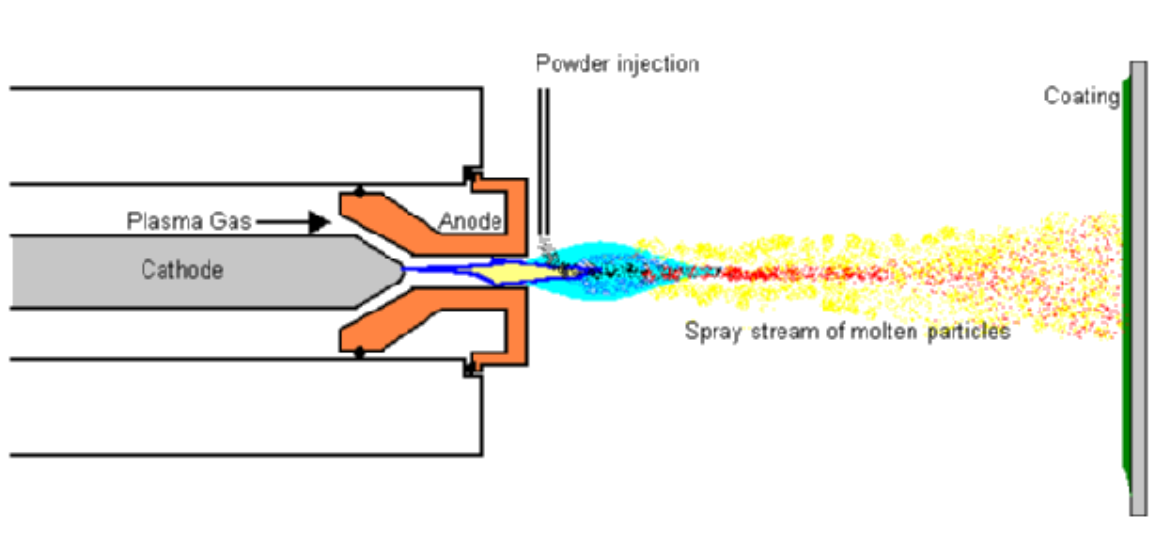

Fig 1.7:-Schematic diagram of Plasma Spray Process

The significant benefit of plasma spray is that refractory material can be sprayed on a variety of substrate materials (composite materials, plastics, metals, ceramics, and glass) [10].

Wire Arc Spray

Wire arc spray is a coating method, which consumes two metal wires and they are fed independently into the spray gun. These wires are then electrically charged, and an arc is produced between them. The heat generated during the process is used to melt the incoming wire, which ejects out as a jet from the gun. This ejected molten feedstock is then deposited onto a substrate with the help of compressed air[11]. The schematic diagram of the electric arc spray system is shown in the figure below.

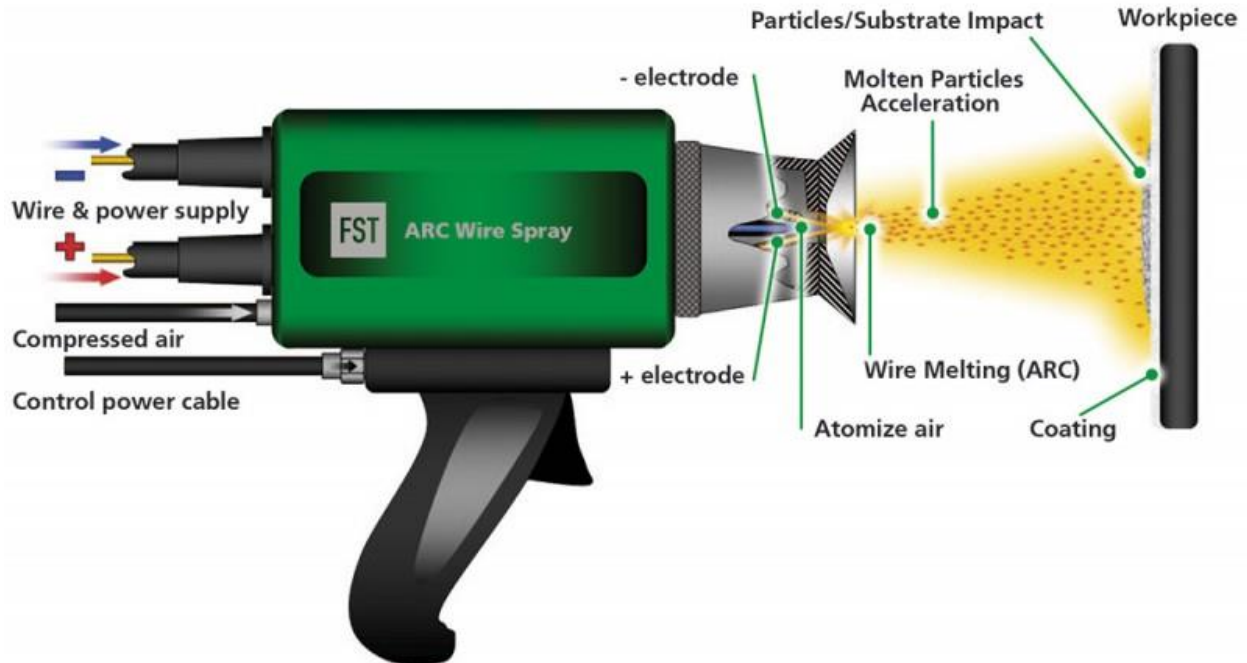

Fig. 1.8:-Schematic diagram of Wire Arc Spray

Based on kinetic energy, the thermal spray process is classified as:

1. Cold Spray

The cold gas dynamic spray is relatively a new spray method which is related to a wide set of thermal spray processes in which usually ceramics, metals, polymers and composites (solid powder particles) etc. are accelerated in a de Laval nozzle (converging-diverging direction) to the substrate. The dense solid powder particles are deposited on the substrate at a temperature (less than the melting point of the powder material) by supersonic speed. If the impact velocities go over a critical limit, powder particles suffer from a permanent deformation and stick to the material surface. Cold spray can be used for depositing nanostructured powders. The schematics presentation of cold spray methods is shown in Fig. 1.9 (a &b).

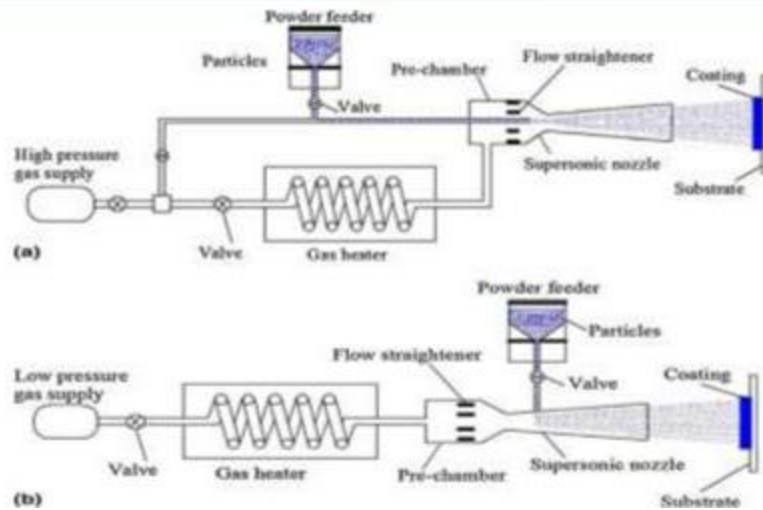

Fig 1.9:-Schematics presentation of cold spray methods

The main benefits of cold spray as compared to thermal spray methods are the low temperature involved with no heat, low porosity (below 1%), high thermal and electrical conductivity, high density, more hardness of coating, improved wear resistance, heat abrasion, high impact strength, oxidation and high corrosion resistance [12]. In cold spray the carrier gas (helium) is very expensive unless which is the drawback of this process. Cold spray finds application in almost every field ranging from the area of aerospace, medical, marine, electronics, machine repair, automotive etc. [6]. Cold spray coating is used widely to produce thick, pure and well-bonded layers of different metals and alloy like Nickel, Aluminum, zinc, copper, silver, tantalum, as well as nickel-base alloys, stainless steel [7].

1. Surface Preparation

To guarantee sufficient bonding of thermal spray coatings, it is critical that a substrate is prepared appropriately. Surfaces must be neat and clean, and usually, substrates must be roughened by grit blasting after cleaning. Indeed, the surface must remain clean by lubricants from handling equipment or by personal contact after it is prepared. It is suggested that the prepared surface must be coated immediately after preparation to prevent the possibility of oxidation of surface or surface contamination.

2. Removal of Contaminants

Rust, oils, grease, lubricants, paint; or other surface contaminants must be removed before the coating deposition process starts. They can be removed by grit blasting, wire brushing, chemical action, scraping, or machining. Precaution should be taken not to insert scale and the like in the surface when trying to remove it, predominantly when using grit blasting. Solvent degreasing has been the most employed method so far, for the removal of lubricants and body contaminants, most appropriately with vapor degreasers.

Large hardware parts, that may be damaged by vapor degreasing, should be degreased by hand using the least treacherous material available. All solvents should be used only in well-aerated areas, by adequately protected workers who are skilled in their work and who follow rule and regulations for the care, use, and handling of solvents.

3. Surface Roughening

Surface roughening includes three methods for thermal spray coatings i.e. grit blasting, rough threading, and a combination of rough threading subsequently with grit blasting. Rough threading is commonly used for cylindrical surfaces and with thick flame sprayed coatings. This technique is limited to thick substrate material to support the machining without knowingly reducing its strength. It is most often used with flame sprayed coatings and is not suggested for thin coatings. Higher bond strengths are attained when threading is followed by grit blasting.

Moreover, one has to be careful that, grit blasting equipment used for thermal spray should not be used for other purposes, because of dirt, and lubricants contaminating the grit. The grit should be constantly monitored to remove fines. The air supply to the grit blast apparatus must be clean and dry. Chilled iron and aluminum oxide are the most

widely used abrasive grits for thermal spray surface preparation. However, sand and silicon carbide are also used in some conditions.

4. Finishing Treatment

Sealing is one of the best-known methods for thermal spray coatings. It is usually employed for coatings with inherent porosity that ranges >2% to more than 15 %, depending on the process by which the coating is deposited and the material used. Some of the porosity has interconnection between its pores. Sealing a coating can help to lower the concentration of particles pullout from the surface during finishing for coatings with considerably low cohesive strength. In such situations, the sealant must be applied necessarily on coating before the final step of finishing. Some common sealant materials are phenolic waxes, epoxies, etc. are easily applied. The wax sealants are beneficial in stopping infiltration of liquids at low temperatures. Resin-based about 260 °C (500 °F), some silicone-based up to 480 °C, Epoxy and phenolic sealants up to about 300 °C. Apart from these sealants vacuum impregnation is one of the most effective methods of sealing coating porosity. This method will typically fill all interconnected pores open to the exterior surface of the coating.

5. Coating Finishing

Some of the thermal spray coatings are too rough for most service conditions. Therefore, they are usually finished by methods such as grinding, polishing, machining, abrasive brushing, or vibratory finishing. Great care must be taken not to damage the coatings during these processes, causing excessive surface porosity due to pullout of coating particles or cracking due to thermal stresses. The ultimate surface finish depends on composition, but also of the deposition parameters used to produce it. Because these parameters define the porosity level in the coating and the cohesive and adhesive strength. In addition to the traditional dimensional finishing techniques mentioned above, some of the known non-dimensional finishing processes are peening, belt grinding and vibratory techniques. The use of non-dimensional finishing is usually possible in rare circumstances.

6. Health, Safety, and Environmental Concerns

There is certain some health, safety, and environmental issues associated with thermal spray coating processes, as with most industrial processes. Specifically, they are related to those associated with welding processes. Evidently, none of the spray processes should be used without proper knowledge and training of all of the workers involved. Particular attention should be given to the hazards associated with the particular materials being used to prepare for or produce the coating. Proper maintenance of the equipment, including all gas and electric lines, cylinders, nozzles will greatly reduce hazards. In addition, proper ventilation and dust collection equipment with the operators outside should be installed. Each spray process has its own airflow obligation to provide satisfactory ventilation, and the equipment producer should be capable enough to provide guidelines. In addition, all workers in the area of the spray operation should have their regular hearing checkup.

7. Applications and Materials

Thermal spraying offers a wide range of benefits, either as part of the original manufacturing process or as a renovation technique. Some materials are used for small function applications and other materials are sprayed by the large setup. Each application uses a set of process and material to yield the desired properties.

A few common applications are rail and road vehicles, ships, paper making machines, pumps, valves, printing presses, aircraft, electric motors, chemical plant, food machinery, mining machinery, machine tools, power generation and aerospace turbine repair, landing gear (chrome replacement) and almost any equipment which is subject to wear, erosion or corrosion. This is done using either arc spray, flame spray or HVOF systems to spray nickel alloys, steels, stainless alloys, bronzes, copper, carbides and many other materials. Component life is significantly prolonged by these techniques.

Spray Process	Spray Materials	Application	Characteristics of the process	Capital expenditure	Operational cost
HVOF	Carbides, Nitrides, Metals, Ceramics	Oil & gas, Paper industry, cylinders, valves, pumps, etc.	Excellent, coating properties: mechanical and thermal properties	<High>	<High>
Plasma	Ceramics, Metals	Print roller, medical	Ceramic coatings have better	<High>	<Medium>

		implants, barrier coatings etc.	properties		
Arc wire	Steel, Aluminum, Zinc	Anti-corrosion coatings, large renovation equipment	More fumes and dust	<Medium>	<Low>
Powder flame spray	Ceramics, Metals	Small replacement work	Portable but have dust and fumes	<Low>	<Medium>
Wire flame spray	Molybdenum, Aluminum & other metals	Anti-corrosion and renovation equipment	Simple function and efficient device	<Low>	<Low>

References: -

1. R. C. Tucker Jr, "ASM Handbook, Volume 5A, Thermal Spray Technology," plastics industry, vol. 335, p. 336, 2013.
2. L. Pawlowski, The science and engineering of thermal spray coatings: John Wiley & Sons, 2008.
3. R. M. Poorman, H. B. Sargent, and L. Headlee, "Method and apparatus utilizing detonation waves for spraying and other purposes," ed: Google Patents, 1955.
4. G. H. Smith, R. C. Eschenbach, and J. F. Pelton, "Jet plating of high melting point materials," ed: Google Patents, 1958.
5. B. Wielage, A. Wank, H. Pokhmurska, T. Grund, C. Rupprecht, G. Reisel, et al., "Development and trends in HVOF spraying technology," Surface and Coatings Technology, vol. 201, pp. 2032-2037, 2006.
6. A. Kumar and N. Singh, "Tribology effect of worn out surface of Aluminium alloy using detonation gun spray coating process," International Journal of Applied Science and Engineering Research, vol. 4, pp. 161-174, 2015.
7. S. Amin and H. Panchal, "A review on thermal spray coating processes," transfer, vol. 2, 2016.
8. L. Pawlowski, "Suspension and solution thermal spray coatings," Surface and Coatings Technology, vol. 203, pp. 2807-2829, 2009.
9. E. Pfender, "Plasma jet behavior and modeling associated with the plasma spray process," Thin Solid Films, vol. 238, pp. 228-241, 1994.
10. L. Sun, C. C. Berndt, K. A. Gross, and A. Kucuk, "Material fundamentals and clinical performance of plasma-sprayed hydroxyapatite coatings: A review," Journal of Biomedical Materials Research: An Official Journal of The Society for Biomaterials, The Japanese Society for Biomaterials, and The Australian Society for Biomaterials and the Korean Society for Biomaterials, vol. 58, pp. 570-592, 2001.
11. R. Li, D. He, Z. Zhou, L. Zhao, and X. Song, "High temperature corrosion behaviour of wire arc sprayed Fe based coatings," Surface Engineering, vol. 30, pp. 573-578, 2014.
12. A. Shkodki, "Peculiarities of the gas dynamic spray applications in Russia," OCPS, Russia, 2010.