



Journal Homepage: -www.journalijar.com

INTERNATIONAL JOURNAL OF ADVANCED RESEARCH (IJAR)

Article DOI:10.21474/IJAR01/13742
DOI URL: <http://dx.doi.org/10.21474/IJAR01/13742>



RESEARCH ARTICLE

INVESTIGATION OF HEAT TRANSFER ON TWO ADJACENT NARROW PLATES WITH NATURAL CONVECTION

Md. Aamir Sohail¹, Ravi Kulkarni H.², P. Rathnakumar², Faheem Akthar², Zeeshan Ali² and Mahadev Nagara³

1. PG Scholar, Department of Mechanical Engineering, Navodaya Institute of Technology, Raichur, Karnataka-584103, India.
2. Department of Mechanical Engineering, Navodaya Institute of Technology, Raichur, Karnataka-584103, India.
3. Aircraft Research and Design Centre, HAL, Bengaluru, India.

Manuscript Info

Manuscript History

Received: 15 September 2021
Final Accepted: 17 October 2021
Published: November 2021

Key words:-

Heat Transfer coefficient, Mass Flow Rate, Pressure, Velocity, Reynolds Number, Overall Heat Transfer Coefficient

Abstract

Natural convection flow in a vertical channel containing inside objects exists in a number of advance technological applications, including heat transfer from electronic circuits, refrigerators, heat exchangers, power station, fueling components, chillers, and residential ventilation, etc. In this thesis the model is created in CREO, and then imported into ANSYS to simulate air flow through vertical thin plates. The focus of the thesis will be on thermal and CFD modeling of vertical thin plates with variable Reynolds numbers (2×10^6 & 4×10^6) and at angles ($0^\circ, 30^\circ$ & 60°) respectively. Thermal analysis was performed on vertical thin narrow plates made up of steel, aluminium, and copper at various heat transfer coefficient rates. Modeling and analysis of the narrow vertical plate is demonstrated utilising the data book's details and design formulary. CFD analysis results tabulated at different Reynolds number, pressure, velocity, heat transfer coefficient, mass flow rate and heat transfer and also which is drawn into graphical representation. 3D modelling was done in the parametric application Pro-Engineer, and analysis is performed in ANSYS.

Copy Right, IJAR, 2021,. All rights reserved.

Introduction:-

In natural convection (NC), the liquid movement happens with the aid of using natural manner consisting of buoyancy. Since the liquid speed related to natural convection is exceedingly low, Furthermore, the heat switch coefficient encountered in natural convection is modest. Consider a hot item uncovered to cold air, the temperature of the outdoors item will drop, and the temperature of adjoining air to the item will rise. Subsequently, Heat may be passed from this layer to the surrounding layers of air because the item is surrounded by a thin layer of hotter air. The temperature of the air adjoining to the hot item is greater; as a result its mass is lower. As a result, the heated air increases. This motion is known as the NC current [1]. Note that within side the nonexistence of this motion, heat transfer might be via way of means of conduction simplest and its charge might be a dreadful lot lower. In a gravitational field, there may be an internet pressure that thrusts a mild fluid located in a heavyweight liquid upwards. This force is referred to as the resistance force.

Corresponding Author:-MdAamirSohail

Address:-PG Scholar, Department of Mechanical Engineering, Navodaya Institute of Technology, Raichur, Karnataka-584103, India.

Natural convection is a thermal energy technique in which fluid movement is best achieved by density differences within the fluid due to temperature gradients, rather than from any external source. Thermal conductivity occurs when a fluid close to a heat source heats up, decreases in density and climbs. This cooled fluid is subsequently heated, and the method is repeated, resulting in conduction and radiation; this process carries heat from the convection cell's rock lowest to the top [2][3]. Natural convection is fueled by buoyancy, which is caused by changes in fluid density. As a result, natural convection requires the presence of a right acceleration akin to that which develops from gravity's resistance, or the same force. NC, for example, does not work well in free-fall conditions, such as those experienced by the circling Space Station International, where different heat transmission techniques are required. As a result of its qualities in nature and in design applications, NC has gotten a lot of attention from analysts. Convection cells formed by air rising over sun warmed land or water are an important part of every climate system in nature. Convection can also be detected in the rising crest of hot air from a fire, marine flows, and the development of ocean wind, advancement. Convection is commonly depicted in applications as the formation of structures during the cooling of liquid metals, as well as liquid streams surrounding covered warmth dispersal blades and sun-based lakes. Free air cooling without the use of fans is a very common modern application of regular convection.

The disadvantages of natural convection over forced convection include: thermal efficiency in NC are typically low by a significant amount. If you look into the challenges we've resolved with forced convection limited convection with air, we got the order of heat transfer coefficient of perhaps 7500W/m² °K. The request for heat natural coefficients with air with natural convection would normally be 10-12W/m² °K. With water, Heat transfer coefficients of the order of might be easily achieved with limited convection of 1000W/m² °K or greater. Water will cause a heat transfer coefficient of two or three many Watts for each metre squared Kelvin during the NC cycle - potentially 20,30, 40 of that request, maybe 10000 and 50, and that's about it. Because coefficients of heat transfer are low, the amount of space needed to transport a given amount of heat is enormous. NC is difficult to control since it is based on thickness contrasts and gravity, the direction of gravity and the direction of the surface play a role, and there is no liquid stream, no blower to turn on or off, and no speed to modify. Let's take a look at some dimensionless no's that are associated with natural convection.

A Vertical Plate With Natural Convection

Natural convection is used to transmit heat from a vertical plate to a liquid moving in the same direction. This can happen in any structure where the thickness of a flowing liquid changes by its position. These marvels may be useful when induced convection has a negligible effect on the moving liquid.

The following relationships can be used when studying the flow of liquid as a result of warming, assuming the liquid is an perfect diatomic, has a nearby vertical plate at constant heat, and the flow of the liquid is completely laminar.

$$Nu_m = 0.478(Gr^{0.25})$$

- Mean Nusselt Number = $Nu_m = h_m L / k$

Where

h_m = mean coefficient applicable between the lower edge of the plate and any point in a distance L (W/m². K)

L = height of the vertical surface (m)

k = thermal conductivity (W/m. K)

- Grashof Number = $Gr = [gL^3(t_s - t_\infty)]/v^2 T$

Where

g = gravitational acceleration (m/s²)

L = distance above the lower edge (m)

t_s = temperature of the wall (K)

t_∞ = fluid temperature outside the thermal boundary layer (K)

v = kinematic viscosity of the fluid (m²/s)

T = absolute temperature (K)

Problem Description & Methodology:-

Using CREO design software, the wind stream through vertically constrained plates is seen. Warm and CFD investigations with various Reynolds numbers (2×10^6 & 4×10^6) and various places (0° , 30° & 60°) of upward limited plates will be the focus of the theory. Warm tests were carried out on the upward thin plates using steel, aluminium, and copper at varied warmth transfer measurement values.

Reynolds numbers	Angle of plate	Material
2×10^6	$0^\circ, 30^\circ \text{ \& } 60^\circ$	Copper
4×10^6		Aluminum

Modelling And Analysis

The narrow vertical plate is demonstrated utilising the data book's details and design formulary. The figure below shows an isometric perspective on a vertically constrained plate. The upward restricted profile plate is portrayed insketcher and afterward it stays expelled perpendicular thin plate utilizing expel alternative.

Narrow Plate Models Using Creowildfire 5.0

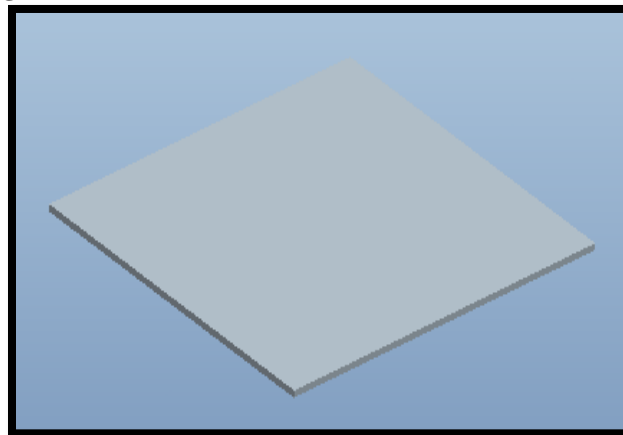

Fig 4.1:- Narrow vertical plate at 0° (3D).

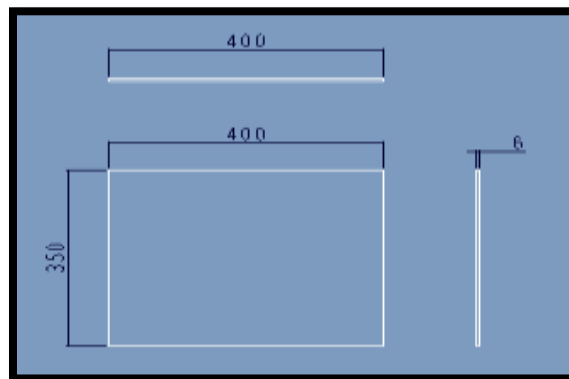

Fig 4.2:- Narrow vertical plate at 0° (2D).

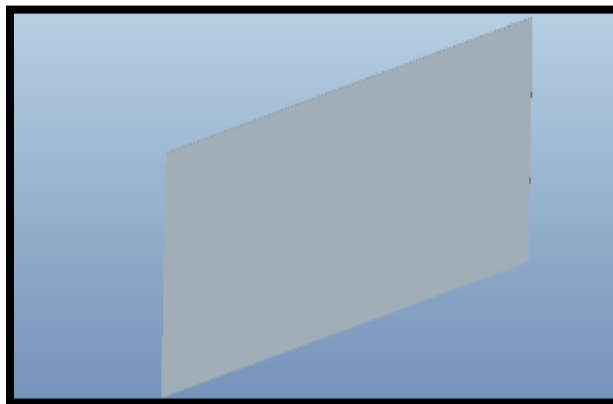

Fig 4.3:- Narrow vertical plate at 30° (3D)

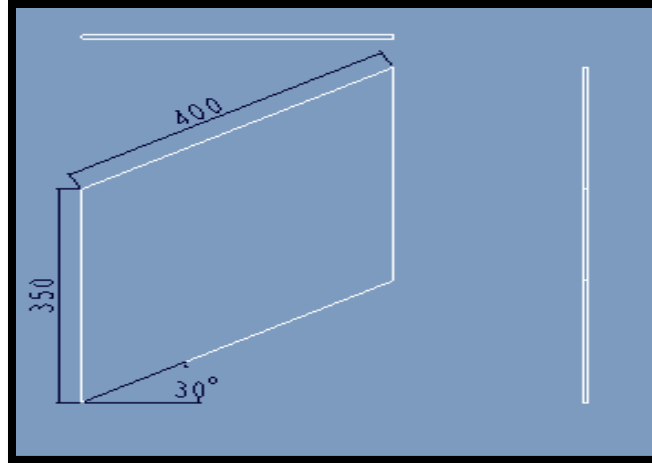

Fig 4.4:-Narrow vertical plate at 30° (2D).

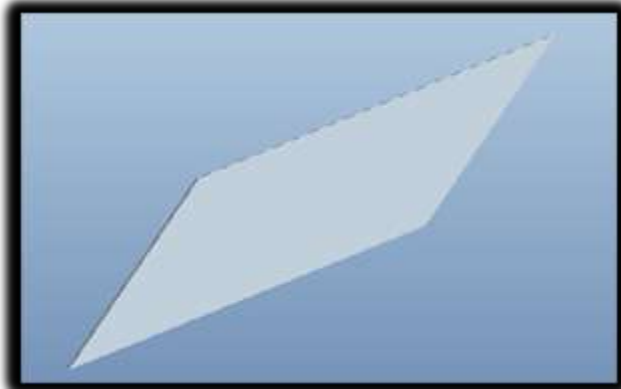

Fig 4.5:-Narrow vertical plate at 60°(3D).

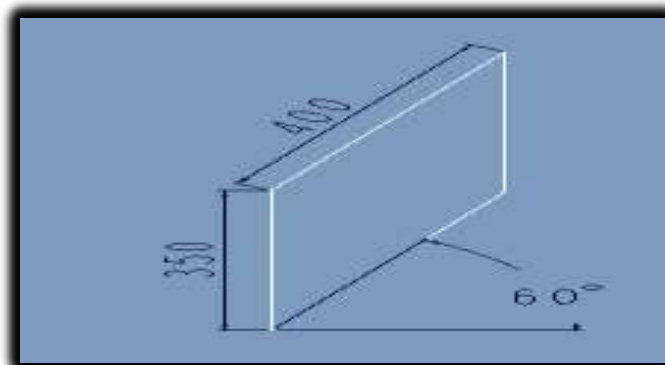

Fig 4.6:-Narrow vertical plate at 60°(2D)

Narrow Vertical Plate Surface Models

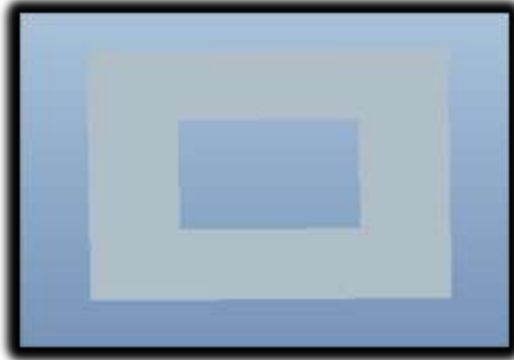

Fig 4.7:- Narrow vertical plate at 0° (3D).



Fig 4.8:- Narrow vertical plate at 30° (3D).



Fig 4.9:- Narrow vertical plate at 60° (3D).

CFD Analysis of Narrow Vertical Plate

REYNOLDS NUMBER 2×10^6 , 4×10^6

FLUID – AIR

PHYSICAL PROPERTIES OF AIR

Thermal conductivity	=	0.024 w/m-k
Density	=	1.225 kg/m ³
Viscosity	=	1.98×10^{-5} kg/m-s

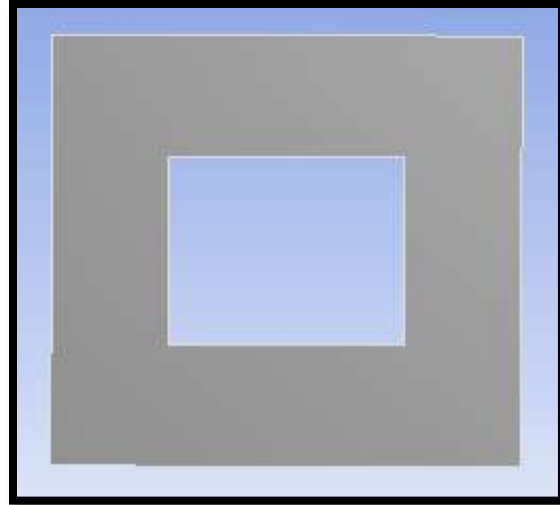

Fig 4.10:- Modeling of plate.

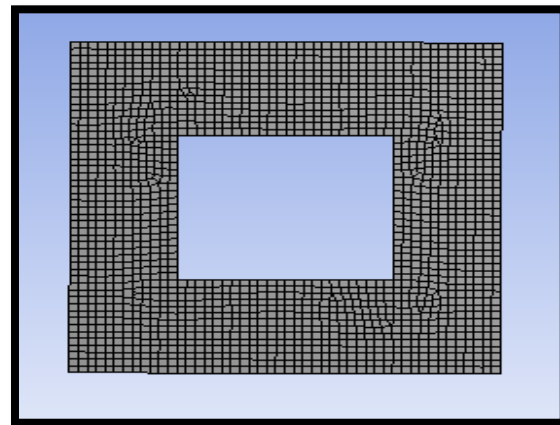

Fig 4.11:- Gridding of plate.

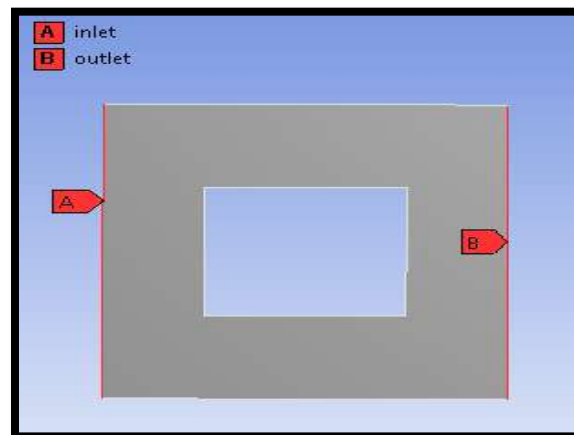

Fig 4.12:- Boundary condition.

The model is created in CREO, then imported into ANSYS for meshing and study. The pressure profile and temperature distribution are calculated using CFD analysis. The fluid ring is separated into two linked volumes for meshing. Then, at 360 intervals, mesh is used on all thickness edges. The mesh is based on a tetrahedral structure. As a result, 6576 nodes and 3344 elements make up the total amount of nodes and elements, respectively.

Result:-**Copper & Aluminum****Copper material properties**

Thermal conductivity = 385 watt/m-k

Aluminum material properties

Thermal conductivity = 30.0 watt/m-k

Boundary Conditions

Fig 5.41:- Applying boundary condition.

Narrow Plate In Vertical Position At 0°**Material – Copper**

The distribution of extreme temperature at the lowest of the NP (Narrow plate), according to the contour plot, since the temperature passes through the lowest of the plate. As a result, we're using the temperature at the lowest of the plate and convection except at the lowest of the plate.

The largest heat flux is found at the corner portion of the NP's, according to the contour map. Except for the corners of the NP, there is a lowest heat flux. The greatest heat flux is 0.15657 watt/mm² and the lowest heat flux is 0.039277 watt/mm², according to the contour plot above.

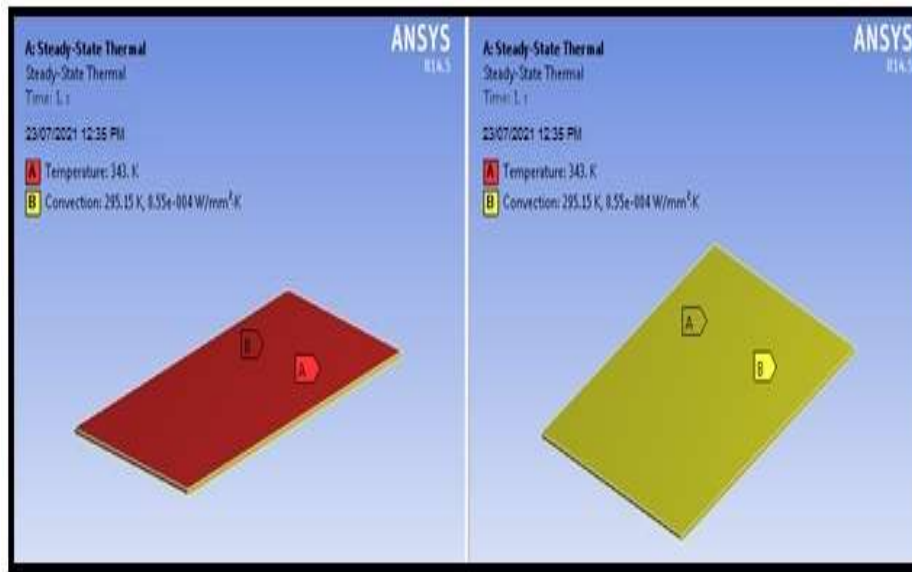
Material – Aluminum Alloy

The spreading of extreme temperature at the lowest of the NP, according to the contour plot, since the temperature passes through the lowest of the plate. As a result, we're using the temperature at the lowest of the plate and convection except at the lowest of the plate.

The largest heat flux is found at the corner portion of the NP's, according to the contour map. Except for the corners of the NP, there is a lowest heat flux. The greatest heat flux is 0.15159 watt/mm² and the lowest heat flux is 0.038387 watt/mm², according to the contour plot above.

Narrow Plate In Vertical Position At 30°**Material – Copper**

The distribution of extreme temperature at the lowest of the NP, according to the contour plot, since the temperature passes through the lowest of the plate. As a result, we're using the temperature at the lowest of the plate and convection except at the lowest of the plate.

The largest heat flux is found at the corner portion of the NP, according to the contour map. Except for the corners of the NP's, there is a lowest heat flux. The greatest heat flux is 0.1951 watt/mm² and the lowest heat flux is 0.039119 watt/mm², according to the contour plot above.

Material – Aluminum Alloy

The distribution of extreme temperature at the lowest of the NP, according to the contour plot, since the temperature passes through the lowest of the plate. As a result, we're using the temperature at the lowest of the plate and convection except at the lowest of the plate.

The largest heat flux is found at the corner portion of the NP, according to the contour map. Except for the corners of the NP, there is a lowest heat flux. The greatest heat flux is 0.18744 watt/mm² and the lowest heat flux is 0.03824 watt/mm², according to the contour map above.

Narrow Plate In Vertical Position At 60⁰

Material – Copper

The distribution of extreme temperature at the lowest of the NP, according to the contour plot, since the temperature passes through the lowest of the plate. So we're using the temperature at the lowest of the plate and convection except at the lowest of the plate.

The largest heat flux is found at the corner portion of the NP, according to the contour map. Except for the corners of the narrow plates, there is a lowest heat flux. The greatest heat flux is 0.38359 watt/mm² and the lowest heat flux is 0.04045 watt/mm², according to the contour plot above.

Material – Aluminum Alloy

The distribution of extreme temperature at the lowest of the NP, according to the contour plot, since the temperature passes through the lowest of the plate. As a result, we're using the temperature at the lowest of the plate and convection except at the lowest of the plate[9].

The largest heat flux is found at the corner portion of the NP, according to the contour map. Except for the corners of the NP, there is a lowest heat flux. The greatest heat flux is 0.35993 watt/mm² and the lowest heat flux is 0.039493 watt/mm², according to the contour plot above.

CFD Analysis Result Table

Using CREO design software, the wind stream through vertically constrained plates is seen. Warm and CFD investigations with various Reynolds numbers (2×10^6 & 4×10^6) and various places (0° , 30° & 60°) of upward limited plates will be the focus of the theory. By considering pressure, velocity, Heat transfer co-efficient, Mass flow rate, Heat transfer rate respectively.

Reynolds number	Models	Pressure (Pa)	Velocity (m/s)	Heat transfer co-efficient (w/m ² -k)	Mass flow rate (kg/s)	Heat transfer rate (W)
2×10^6	0°	2.59e+04	2.22e+02	3.14e+02	0.0141983	57075.5
	30°	3.25e+04	2.80e+02	3.39e+02	0.13510132	2022.375
	60°	1.16e+05	5.01e+02	4.93e+02	0.50804138	9873.625
4×10^6	0°	1.03e+05	4.44e+02	5.52e+02	0.02565	120081
	30°	1.31e+05	5.60e+02	5.96e+02	0.86120605	12874.25
	60°	4.65e+05	1.00e+03	8.55e+02	1.05348	20294.25

Thermal Analysis Result Table

Analysis results are tabulated in below table. Considering model, material, temperature & heat flux respectively.

Models	Materials	Temperature (⁰ C)		Heat flux (w/mm ²)
		Max.	Min.	
0°	Aluminum	343	339.2	0.15159
	Copper	343	341.76	0.15657
30°	Aluminum	343	338.22	0.18744
	Copper	343	341.41	1.1951

60 ⁰	Aluminum	343	335.2	0.35993
	Copper	343	340.34	0.38359

CFD Analysisgraphs

By arising the inlet Reynoldsnumbers and increasing the plate angles, the pressure drop and velocity rise as seen in the CFD analysis. Heat transfer rate increases as inlet Reynolds numbers rise, resulting in higher heat transfer at 0⁰ angles.

The booked varied the numbers for heat transfer coefficients come from a computational fluid dynamics (CFD) study, as seen in the thermal analysis. Copper has a higher heat flux value than steel and aluminium.

As a result, we can determine that copper is a best material for narrow vertical plates.

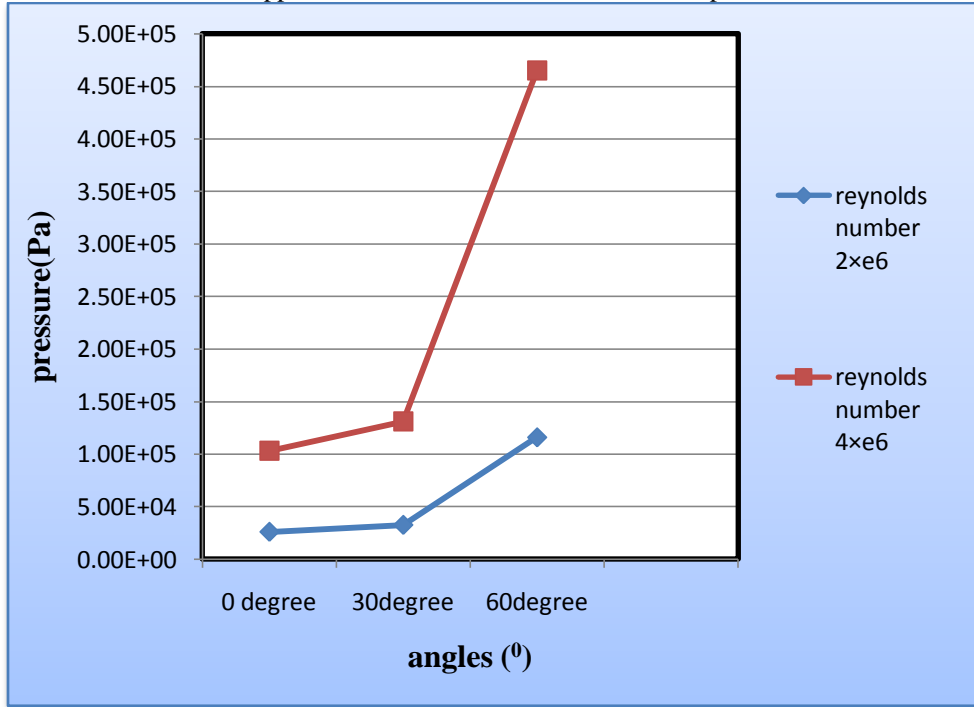

Graph1:- Pressure plot.

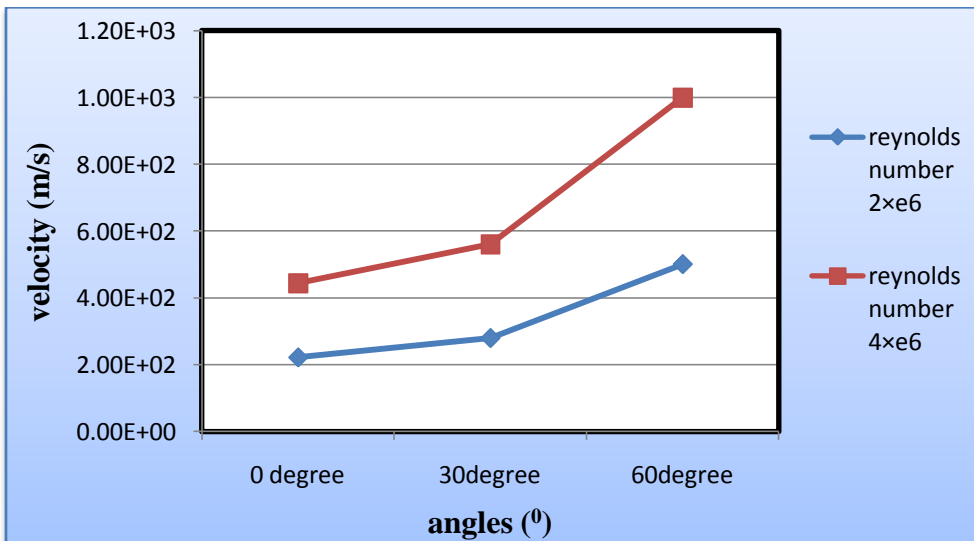

Graph 2:- Velocity plot.

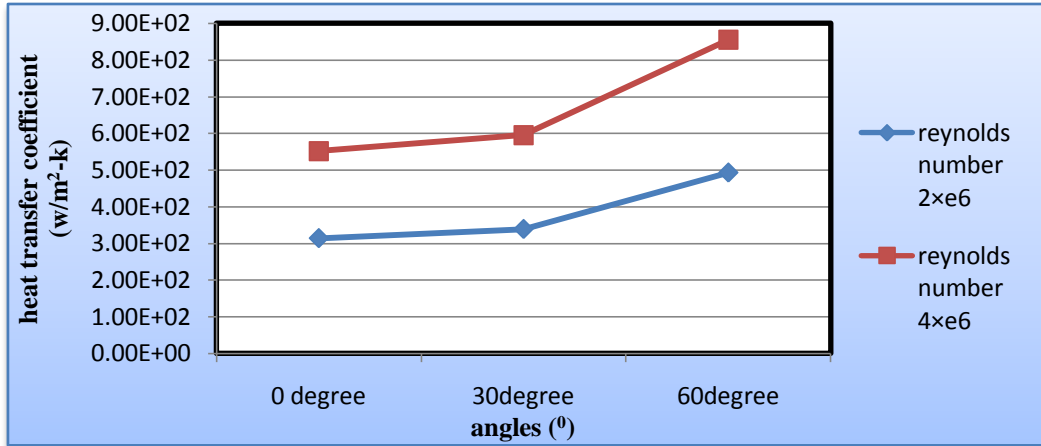

Graph 3:- Heat transfer coefficient plot.

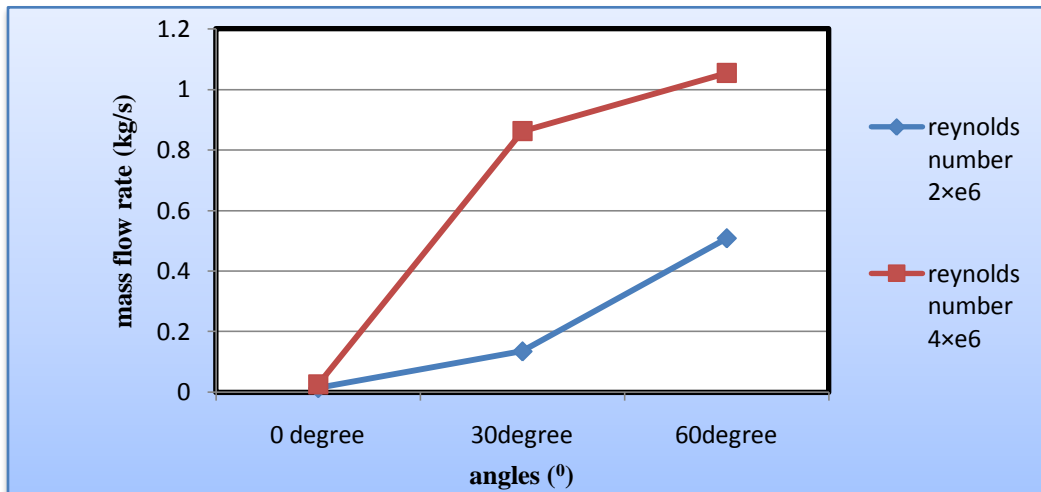

Graph 4:- Mass flow rate plot.

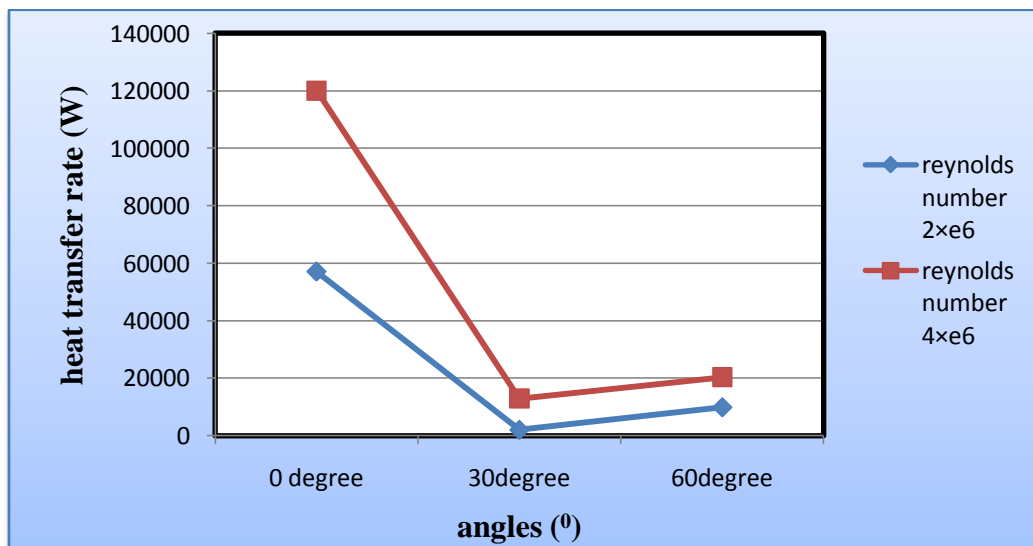

Graph 5:- Heat transfer rate plot.

Conclusion:-

1. Vertical narrow plates allow air to pass across them is modelled using CREO design software in this thesis. Thermal and CFD study of vertical narrow plates will be the subject of the thesis with varied Reynolds numbers (2×10^6 and 4×10^6) and angles (0° , 30° & 60°).
2. Thermal examination of vertical narrow plates made of steel, aluminium, and copper with various heat transfer coefficients. These figures are based on CFD simulations at various Reynolds numbers.
3. By raising the Reynolds numbers in the inlet and increasing the plate angles, the pressure drop and velocity rise according to the CFD study.
4. Heat transfer rate increases as inlet Reynolds numbers rise, resulting in higher heat transfer at 0° angles.
5. The taken varied heat transfer coefficient values are from CFD study, as seen in the thermal analysis.
6. Copper has a higher heat flux value than steel and aluminium.
7. As a result, we can deduce that copper is a superior material for narrow vertical plates.

References:-

1. Arpaci, V. S., 1995, "Buoyant Turbulent Flow Driven by Internal Energy Generation," Int. J. Heat Mass Transfer, Vol. 38, pp. 2761-2770. Asfia, F. J., and Dhir, V. K., 1994.
2. Experimental Study of Natural Convection in a Volumetrically Heated Spherical Pool with Rigid Wall," ASME Paper 94-WA/H7--26.
3. Cheung, F. B., 1980a, "Heat Source-Driven Thermal Convection at Arbitrary Prandtl Numbers," J. Fluid Mech., Vol. 97, pp. 743-758.
4. Cheung, F. B., 1980b, "The Boundary Layer Behavior in Transient Turbulent Thermal Convection Flow," ASME JOURNAL OF HEAT TRANSFER, vol. 102, pp. 373-375.
5. Cheung, F. B., 1978, "Turbulent Thermal Convection in a Horizontal Fluid Layer With Time Dependent Volumetric Energy Sources." AIAA/ASME Thermo physics and Heat Transfer Conf., 78-HT-6, Palo Alto.
6. Kulkarni H Ravi, Dhanasekaran C, Rathnakumar P, Sivaganesan S. Experimental study on thermal analysis of helical coil heat exchanger using Green synthesis silver nanofluid. Materials Today: Proceedings 2021;42:1037-42.
7. Ravi Kulkarni H, Dr.P.Rathnakumar, Dr.C.Dhanasekaran, Faheem Akthar (2021), "Review on thermal analysis of helical coil heat exchanger using nanofluid" International Journal of creative Research thoughts, Vol.9, Issue 5, pp. h249-h255.
8. P. Rathnakumar, K. Mayilsamy, S. Suresh and P. Murugesan (2013), "Comparison of Heat Transfer and Friction Factor Characteristics of CNT based Nanofluids in a Circular Tube fitted With Helical Screw Inserts with Spacers", Journal of Nanofluids 2 (4), 274-282.
9. H. Ravi. Kulkarni, P.P. Revankar, S.G. Hadagal, "Energy and Exergy Analysis of Coal Fired Power Plant", International Journal of Innovative Research in Technology & Science, Vol. 1 no. 3, pp. 53-57, 2013.
10. P. Rathnakumar, Madan D and Ravi Kulkarni H, "Enhancements Of Thermal Performance Factor In Turbulent Flow Through A Tube Fitted With Helical Screw Louvered Rod Inserts", International Journal of Innovative Research in Advanced Engineering, vol. 6, issue 6, Pages 24-29. ISSN 2349-2163.
11. Balaraju M O, H. Ravi Kulkarni, P. Rathnakumar, Faheem Akthar, "Augmentation on heat transfer in shell and coil type heat exchanger using nano fluid" International journal of scientific research in science engineering and technology, vol. 8, issue 5, page 62-69, ISSN : 2394-4099.
12. Zeeshan Ali, Pradeep Kumar Ilay, Mohd Umar, Madeva Nagaral 'Investigations of Mechanical Properties on Copper Alloy & Graphite as Reinforcement' in International Journal of Engineering Research & Technology (IJERT), 2019, Volume 7, Issue 7 pp 1-4. ISSN-2278-0181
13. M D Umar, Zeeshan Ali, Meer Ashfaqwali, Syed Mudasser UIHuq, Mohammed Irfan, Mohmmedsoghailchowdary 'Mechanical Behavior of Aluminium-7075 Reinforced with Boron Carbide (B4C) and Graphite (Gr) Synthesized by Stir Casting' in I International Journal of Engineering Research & Technology (IJERT), May 2019, Volume 6, Issue 5 pp 5204-5208. ISSN-2395-0056
14. Zeeshan Ali, V. Muthuraman, P Rathnakumar, P. Gurusamy, Madeva Nagaral 'Investigation on the tribological properties of copper alloy reinforced with Gr/ZrO2 particulates by stir casting route' in Materials today proceedings ELSEVIER, Materials Today: Proceedings 33 (2020) pp 3449-3453.
15. Rathnakumar, K. Mayilsamy, S. Suresh and P. Murugesan (2013), "Experiments on turbulent heat transfer and friction factor in reaction with carbon nanotube based nanofluids", International Journal of mechanical and materials Engineering 8 (2), 116-126.