



Journal Homepage: -[www.journalijar.com](http://www.journalijar.com)

## INTERNATIONAL JOURNAL OF ADVANCED RESEARCH (IJAR)

Article DOI:10.21474/IJAR01/13836  
DOI URL: <http://dx.doi.org/10.21474/IJAR01/13836>



### RESEARCH ARTICLE

#### SMART WHEELCHAIR/VEHICLE FOR PHYSICALLY CHALLENGED PEOPLE WITH REVERSE GEAR OPERATION

M. Selvaganapathy<sup>1</sup> and N. Nishavithri<sup>2</sup>

1. Asst. Professor, Dept. of ECE, CK College of Engineering and Technology, Cuddalore, Tamil Nadu.
2. Asst. Professor, Dept. of ECE, Mailam Engineering College, Mailam, Tamil Nadu.

#### Manuscript Info

##### Manuscript History

Received: 30 September 2021  
Final Accepted: 31 October 2021  
Published: November 2021

##### Key words:-

Smart Bike, Physically Challenged People, Tumble Gear Mechanism, Reverse Gear Operation, etc

#### Abstract

This paper aims to design the vehicle for the physically challenged person with reverse gear system. This proposed vehicle helps them not to believe any third persons to require a reverse gear. Here we used "tumbler gear" mechanism for our prototype where the gear is accustomed by changing the direction of gear. It contains two gears which place in parallel by changing their position with motor direction; that are often changed but in real time application we'd wish to use ideal gear system with gear box. Also the bike contains ultrasonic sensor which supports echo signals to supply alert on taking reverse to avoid collision between other object. This technique also contains "GPS" which help their family to locate the position of the physically challenged person just easily. In case of any emergency, an ultrasonic sensor, GPS module and relay circuits are employed to drive the motor in our prototype.

Copy Right, IJAR, 2021., All rights reserved.

#### Introduction:-

Nowadays while crossing in many situations, we can see that the physically challenged people are really struggling to reverse their vehicle where they actually need an assistance of individuals. We partially proposed a solution for them where the vehicle can work with reverse direction using "Tumbler Gear" mechanism but once we attend normal motor bike we'd wish to suit a gear box with ideal gear, allow us to see how it works.

#### Tumbler gear

The mechanism serves as the neighborhood and want to transfer one quite motion into other types. There are many types of mechanisms. The tumbler gear is typically used to change the direction of feed rod and lead screw. The mechanism is usually described as a gathering of drums wheels which is employed to reverse the direction of rotation of any machinery. During this mechanism, the technique used is, increasing the amount of engaged gear which can be easily performed.

The below diagram is clearly explaining the tumbler gear concept. When the lever connected with gear 'A' is in normal position and rotates during a forward direction. The lever 'B' is connected to the motor and rotates in backward direction. Mechanism Back gears (BG) mounted on an eccentric shaft is handled to rotate an eccentric mounting shaft which engages the rear gears Pin (P) to attach and disconnect Bull Wheel and V-pulley. Lathe uses stud and nut arrangement instead of a pin for a quick-release fitting. During a Bull Wheel condition, the locating plunger will undergo the front face of the headstock casting. The rear gear could also be a clever but essentially

**Corresponding Author:-M. Selvaganapathy**

Address:-Asst. Professor, Dept. of ECE, CK College of Engineering and Technology, Cuddalore, Tamil Nadu.

simple mechanism probably conceived around 1817 by Richard Roberts, an English engineer and prolific inventor. If you've to read subsequent several time to understand how it works, don't be concerned , everybody does within the image below (a 1934 Atlas lathe) the 4-step V-pulley (V) features a little gear (SG) permanently attached to its smaller end. The entire length of V-pulley and kit are bushed - and prepared to rotate freely on the headstock spindle.

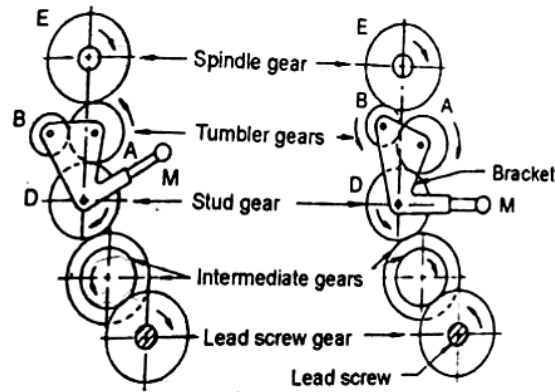

Fig. 1:- Tumble gear.

## II. Components of the proposed Vehicle:

### a. Wheel Assembly (Supporting Wheels)

1. For providing grip within the road areas/surfaces.
2. For providing the flexibility for shocks.
3. For perfect equilibrium.

### b. Tyre Assembly

1. For providing Load support.
2. For providing shocks cushion.

### c. suspension

1. For separating the axle and wheels.
2. For isolating auto from shocks and vibrations.

## Objective:-

### General Objective

The general objective of the research is to design the user friendly vehicle for physically challenged people.

### Specific Objective:

1. The specific objective of the research includes:
2. To improve the system with tumble gear mechanism.
3. To design the system with collision avoidance facility.
4. To build the GPS enabled system for the location tracking of the physically challenged people.

### Block Diagram

The following figure represents the block diagram of the proposed system where the block diagram consists of

1. Joystick.
2. Wheel Chair Controller.
3. Tumble Gear.
4. DC Motor.
5. GPS System and
6. Ultrasonic Sensor.

The Joystick is used to position the vehicle in the desired direction. And the controller used here is Arduino UNO. The tumble gear is used to drive the vehicle in the reverse direction. With this tumble gear, we can easily change the wheel chair/vehicle position in backward direction. The DC motors are used to rotate the vehicle in the desired forward/reverse directions. The GPS system is used to track the position of the physically challenged people and the

ultrasonic sensors are used to alert the user if any obstacles are observed during the movement of vehicle in reverse direction.

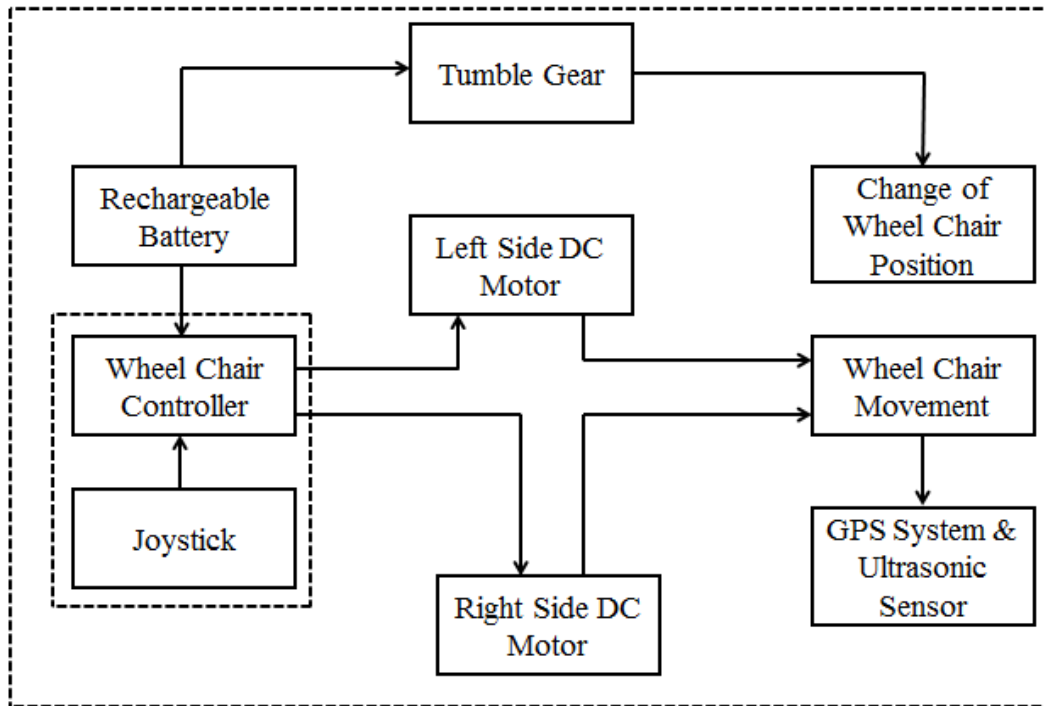

Fig. 2:- Proposed Block Diagram.

## Hardware Components

### Ultrasonic sensor

An ultrasonic sensor emits an ultra sound at 40 MHz. These waves will travel through the air and if any objects or obstacle occurs on its path then it'll recover to the module. Considering the quantity of some time and thus the speed of the sound you'll calculate the space. The sensor has 4 pins: Ground Pin, VCC Pin, Trigger Pin and an Echo Pin. Rock bottom and thus the VCC pins of the module must be connected to rock bottom and thus the 5 volts pins on the Arduino Board respectively. So on get the ultrasound you'd wish to line the Trig on a High State for 10  $\mu$ s which send 8 cyclic burst which travels at a speed of sound and it might be received with the Echo pin. The Echo pin will give time as an output which may be obtained in microseconds.

An ultrasonic sensor could even be a tool which can measure the space of the thing by using acoustic wave at a selected frequency and listening for that acoustic wave to recover. By recording the number of bursts between the sound waves generated and thus the acoustic waves are bouncing back. Here we connected it to the Arduino and placed at rear of the vehicle which measures the space between the thing behind the vehicle and provides signal to the Arduino board to which connected to buzzer to supply sound when certain distance is reached to avoid accidents. The sensor module contains four pins ground, VCC, trigger, Echo which rock bottom and VCC are connected to respective supply pins with Arduino and trigger and echo connected to any digital I/O pins of Arduino board.

### Arduino UNO

Arduino UNO is known for marking the upcoming release of microcontroller board namely Arduino Uno Board 1.0. This board includes digital I/O pins-14, an influence jack, analog i/ps-6, ceramic resonator-A16 MHz, a USB connection, an RST button, and an ICSP header. Of these can support the microcontroller for further operation by connecting this board to the personal computer. The facility supply of this board is often through with the help of an AC to DC adapter, a USB cable, otherwise a battery.

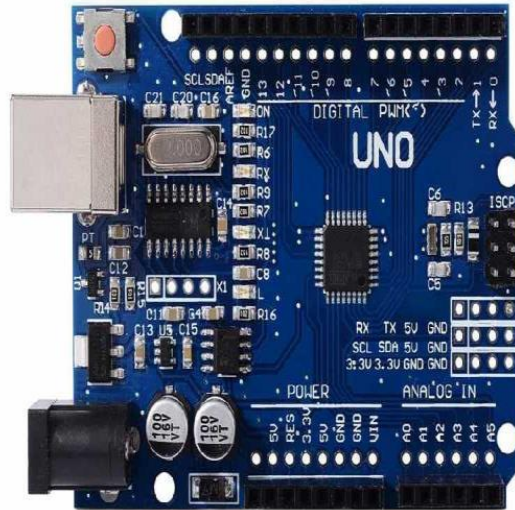

**Fig. 3:-** Arduino UNO.

The ATmega328 is a single-chip microcontroller belonging to an AVR family. The architecture of Arduino Uno follows a customized Harvard architecture with 8bit RISC processor core. The various Arduino Uno boards include Arduino Due, Arduino Mega, and Arduino Leonardo, etc. The Arduino UNO board is pre-programmed with the help of embedded C in Arduino IDE compiler. The board is used to control the GPS module; Buzzer and display to offer instructions and obtain the right output which is definitely programmable and cheap to install. Totally it acts as brain for those systems which need low power and high efficiency.

#### **GPS Module**

The GPS module is used to locate/track the position of the vehicle in case of any emergency. If any accidents happen to the physically challenged people, then with this module one can easily find the location easily. It needs 12V for transmitting the GPS coordinates to remote location with a small GPS receiver which receives another HC-12 transceiver which is processed by Arduino board. The GPS module for Arduino is a small electronic circuit which permits to attach to your Arduino board to urge position and altitude, also as speed, date and time on UTC.

#### **Buzzer**

The device that is employed for alerting the users once it reaches the brink distance from the object behind vehicle it's connected to the Arduino board; that gets the signal from the supersonic about the gap. Here we have a tendency to use a sixty rpm motor for our example that makes the small gear to run.

#### **Advantages of the projected System**

1. Extremely snug.
2. Straightforward reverse gear operation.
3. Freelance of others.
4. Improved steering level.
5. Reduced time.

#### **Conclusion and Future Work:-**

The main difficulties of any physically challenged people are taken as a main consideration in this system. This paper proposed a novel solution for driving two wheelers in reverse direction. But in large scale, we need to improve this system further. Our future work will rely on the cost optimization and autonomous driving system.



**Fig. 4:-** Prototype with Tumble Gear Mechanism.

### References:-

1. N. Nishavithri, B. Dheepa, R. Nithya, Selvaganapathy Manoharan, "Vehicle for Physically Challenged Person using Tumble Gear", European Journal of Molecular and Clinical Medicine, ISSN No. 2515 – 8260, pp. 2509 – 2513, Vol. 7, Issue 4, 2020.
2. M. Selvaganapathy, N. Nishavithri, T. Manochandar, G. Manikannan, "Modern vehicle for the physically challenged people using blue eye technology", International Journal of Mechanical Engineering and Technology, 8 (1), 2017, pp. 208 – 212.
3. M. Selvaganapathy and N. Nishavithri, "Smart Wheel Chair using Neuro – Sky Sensor", International Journal of Advance Research in Computer and Communication Engineering, Volume 4, Issue 11, November 2015, P. No. 361 – 366.
4. Selvaganapathy Manoharan, Nishavithri Natarajan, "Brain controlled wheelchair for the physically challenged people using Neuro – Sky Sensor", International Journal of Innovative Research in Science, Engineering & Technology, Volume 4, Issue 12, December 2015, P. No. 11985 – 11992.
5. Ananda Mani Paudel and Philipp Kreutzmann "Design and performance analysis of a hybrid solar tricycle for a sustainable local commute", volume 41, pp. 473-482, 2014.
6. Ravikumar Kandasamy, Sachin Raut, Deep Varma, Ganesh There, "Design of Solar Tricycle for Handicapped Person", volume 5, issue 2, pp. 11-24, 2013.
7. Mohd Razali Md Tomaria, Yoshinori Kobayashia, Yoshinori Kunoa, "Development of Smart wheelchair system for a user with severe motor impairment", International Symposium on Robotics and Intelligent Sensors, volume 41, pp. 538-546, 2012.
8. Po Er Hsu, Yeh Liang Hsu, Kai Wei Chang and Claudius Geiser "Mobility assistance design of the Intelligent Robotic Wheelchair", International Journal of Advanced Robotic Systems, volume 9, pp. 1-10, 2012.
9. Giuseppe Quaglia, Walter Franco and Riccardo Oderio "Wheelchair.q, a motorized wheelchair with stair climbing ability", Mechanism and Machine Theory, volume 46, pp. 1601-1608, 2011.
10. Margaret Ducusinha "Modeling of a Series Hybrid Electric High-Mobility Multipurpose Wheeled Vehicle in the journal IEEE TRANSACTIONS ON VEHICULAR TECHNOLOGY, VOL. 56, NO. 2, MARCH 2007.
11. Lucas H.V. van der Woude, Sonja de Groot and Thomas W.J. Janssen, "Manual wheelchairs: Research and innovation in rehabilitation, sports, daily life and health", Medical Engineering & Physics, volume 28, pp. 905–915, December 2005.
12. elim s.awad "Voice technology in the instrumentation of the automobile", member IEEE P.K. Nag, J.T. Panikar, M.G. Malvankar, C.K. Pradhan and S.K. Chatterjee, "Performance evaluation of lower extremity disabled people with reference to handcranked tricycle propulsion", Applied Ergonomics, volume 13.3, pp. 171-176, 1982.
13. Madarasz R.L., Heiny LC, Crompt R.F. and Mazur N.M. (1986). "The design of an Autonomous Vehicle for the Disabled", IEEE Journal of Robotics and Automation, vol. RA2.