



Journal Homepage: - www.journalijar.com

INTERNATIONAL JOURNAL OF ADVANCED RESEARCH (IJAR)

Article DOI: 10.21474/IJAR01/17646

DOI URL: <http://dx.doi.org/10.21474/IJAR01/17646>



RESEARCH ARTICLE

DEVELOPMENT OF A PLATFORM TO TEST THE SOLAR PHOTOCELL UNDER THE INFLUENCE OF INCLINATION, TEMPERATURE AND HUMIDITY: USE OF EMBEDDED SYSTEMS

Abdoulaye DIOP¹, Ousmane SOW², Youssou TRAORE², Mame Andallah DIOP², Jupiter NDIAYE¹,
Ababacar Sadikh FAYE¹ and Oumar DIALLO²

1. ED2DS. Iba Der Thiam University. Thiès. Senegal.
2. University Institute of Technology. Iba Der Thiam University. Thiès. Senegal.

Manuscript Info

Manuscript History

Received: 28 July 2023

Final Accepted: 31 August 2023

Published: September 2023

Key words:-

Automation, Characterization, Arduino, Electronics, Tilt Angle, Temperature, Humidity, Photovoltaic Solar Panel

Abstract

This work presents the development of an experimental platform of the solar photocell under the influence of inclination, humidity temperature with the use of embedded systems. This system consists of 8 resistive loads with different values each connected to an NPN type transistor coupled to an instrumentation chain. A digital control programmed by an ATmega electronic board allows the automation of the variations of the resistive load fed by a solar panel of 19V 5 W of power. A computer program developed on the basis of an algorithm according to the defined operation, drives the Arduino electronic board. The movement of the sun during the day leads to the consideration of angle of incidence. During experiments this fundamental parameter is set electronically for automatic acquisition with the parameters: of the solar panel temperature, ambient temperature and humidity in the environment. The automatic variation of the resistive load with the combinations of the 8 electrical resistors to obtain 256 measurements in a few milliseconds. This speed of measurement makes possible the assumption of constant sunshine during the characterization, with a high number of points, of current-voltage curves of the photovoltaic solar cell with good precision.

Copy Right, IJAR, 2023.. All rights reserved.

Introduction:-

Faced with demographic and industrial growth, our countries' energy needs are constantly growing. In the meantime, the so-called «renewable» energies are used. Despite its enormous potential, solar energy is the most exploited and corresponds to only a negligible part of the production and consumption of energy in Senegal [1,2] The exploitation of solar radiation is competitive on several levels compared to other renewable energy sources. The solar cell as a solar energy converter leads us in a tank to study parameters influencing: temperature, humidity.

Solar cells operate under the influence of several internal or external parameters: technology, solar panel orientation, environment, dust, temperature, humidity...

On the one hand, these parameters have been studied in theories from the density of the minority load carriers, the density of photocurrent, photovoltage, I-V characteristics, serial resistors and shunt, the capacity of the solar cell. [3-6]

Corresponding Author:- Abdoulaye DIOP

Address:- ED2DS. Iba Der Thiam University. Thiès. Senegal.

On the other hand, experimentation with solar photovoltaic generators is often done manually with common laboratory instruments [7-9]. However, this method of manual measurement contains errors that are not negligible. [10] Solar lighting during the day poses the problem of the speed of measurements which must also be numerous to be representative of the physical phenomena involved in semiconductors.

The objective of this work is to:

- i) Design an experiment platform to automate loads, [11] with industrial technologies, embedded systems, during experiments on the solar photocell.
- ii) Parameters (inclination angle, sun tracking, atmospheric dust, electromagnetic disturbance, etc.) and data acquisition (current, voltage, temperature, humidity, illumination level) at a distance for pooling resources between research structures.
- iii) Study the photopile by processing data acquired using computer algorithms using powerful mathematical tools.

Automatic device of the variation of the resistive load of the solar cell

The method consists in remotely controlling the value of an equivalent electrical resistance; this thanks to digital electronics. The principle is to put in parallel the electrical resistors taken among a set of n resistors. We proceed by a binary variable association using static switches. The status of the Tx switch determines the status of the Rx resistance relative to the association. The experimental design is shown in Figure 1

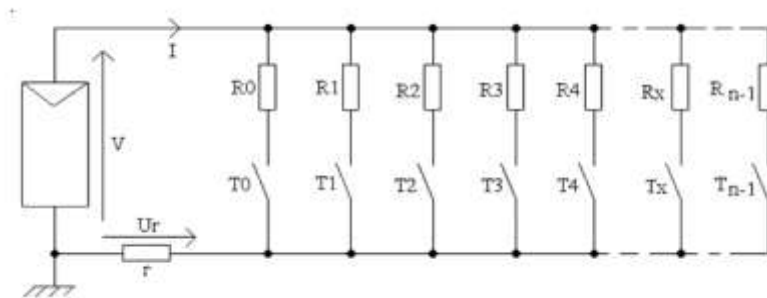

Figure 1:- Automatic characterization scheme of the solar cell.

Numerical equivalent resistance block diagram

In Figure 2, we propose the association of binary variables of transistors with the association of electrical resistors.

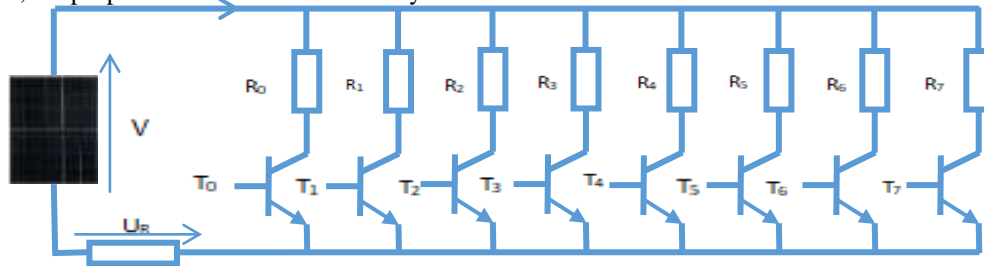

Figure 1:- Schematic diagram of the automatic characterization of a solar panel.

Equation of the numerical equivalent electrical resistance

For the calculation of the resistance association, the value of the equivalent resistance is determined by using the formula expressed by the following equation:

$$\frac{1}{R_{eq}} = \sum_{x=0}^{n-1} T_x \cdot \frac{1}{R_x} \quad (1)$$

For a numerical function with binary n variables, the equivalent electrical resistance is given by the following formula:

$$R_{eq} = f(T_0, T_1, T_2, T_3 \dots \dots T_{N-1}) \quad (2)$$

This numeric function has a countable number of defined values. The following expression expresses N as a function of n

$$N = 2^n \quad (3)$$

Numerically controlled electrical resistance control laws

The numerically controlled electrical resistor, the sequencer controls the transistors through binary signals that obey a logic. To obtain a command law, let us define a binary number A having as digits the n binary variables associated with the n transistor, thus A is presented as a continuation:

$$A = T_{n-1} \dots T_x \dots T_0 \quad (4)$$

The decimal representation of the binary number denoted D which is a natural integer defined at 2^n that is to say going from 0 to 2^{n-1} is to formula:

$$D = T_{n-1} \cdot 2^{n-1} + \dots T_x \cdot 2^x + \dots + T_0 \cdot 2^0 \quad (5)$$

$$\frac{1}{R_{eq}} = \frac{T_{n-1} \cdot 2^{n-1}}{R_{n-1} \cdot 2^{n-1}} + \frac{T_{n-2} \cdot 2^{n-2}}{R_{n-2} \cdot 2^{n-2}} + \dots + \frac{T_x \cdot 2^x}{R_x \cdot 2^x} \dots + \frac{T_0 \cdot 2^0}{R_0 \cdot 2^0} \quad (6)$$

By identifying the binary number D, we will have as equation : $R_{eq} = \frac{R_0}{D}$ (7)

Experimental device with 8 charge electrical resistors

The experimental set up is composed of n = 8 load resistors. A value of 10 Ω is arbitrarily set for the first electrical resistance R₇. Thus the transition from one position to the next doubles the resistance value according to Table 1.

Table 1:- Regulated electrical resistance values.

R ₇	R ₆	R ₅	R ₄	R ₃	R ₂	R ₁	R ₀
10 Ω	20 Ω	40 Ω	80 Ω	160 Ω	320 Ω	640Ω	1280 Ω

The value of the equivalent electrical resistance R_{eq} is obtained according to the order law with $R_{eq} = \frac{1280}{D}$ (8)

For each load resistor, place static switches of the transistor type NPN which plays the role of switching between the electrical resistors of charge.

Control of the digital equivalent resistance controlled by an ATmega electronic board

Let’s develop a basic algorithm for the study of the static and transient regime. The resistance load is supplied by the PV solar panel. The program from the algorithm allows the selection of loads. The delay between two consecutive states is done automatically via the program set up. The resistor connected to each base of the transistor is used to fix the current for switching transistors. We schematize the control device on figure 3.

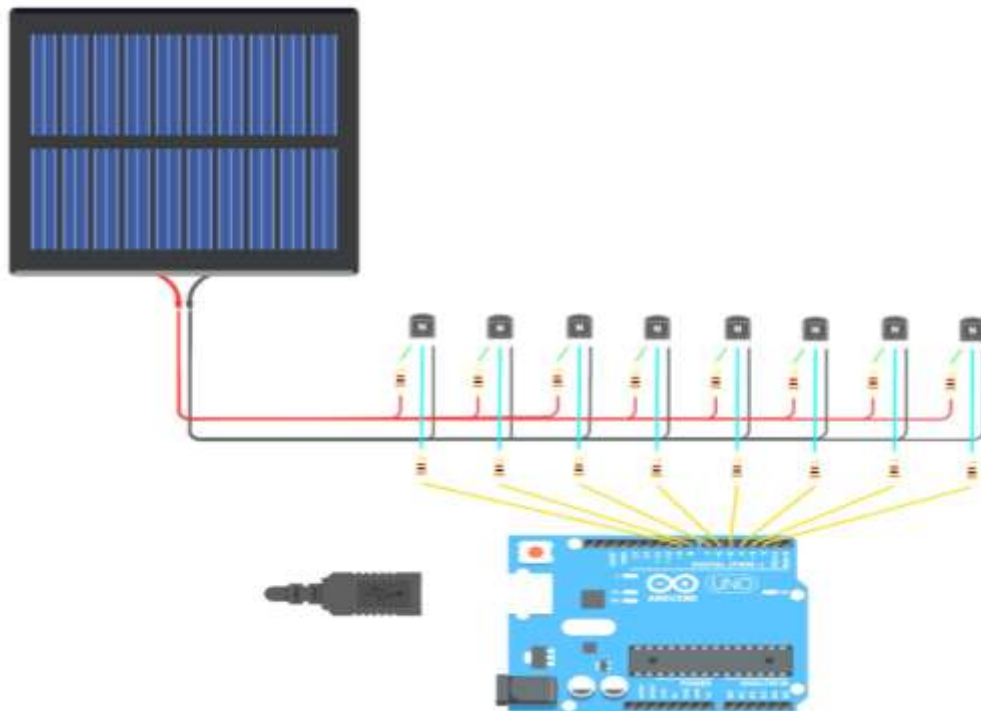

Figure 3:- Automatic programming of the experimental solar panel process.

Control solar tracker using ATmega electronic board for solar panel and tilt angle.

The proposed system includes the installation of the photovoltaic module on a plastic structure, all put on a vertical support. In order for the system to follow the movement of the sun, the ATmega microcontroller, an open source hardware, is used via its digital and analog ports and is connected to the computer via a USB cable.

It is fixed two photoresistors on both ends with a light field separator. The information sent by the photoresistors is processed by the ATmega microcontroller which controls a servo motor of 25Kg ,12V and loads (resistance) by switching. [12] The solar module attaches automatically to the azimuth. A voltmeter and a digital ammeter are placed to visualize the voltage and current at each load rotation to plot the characteristic I-V curve shown in Figure 4.

Figure 2 : representation of photovoltaic solar panel device servo motor, photoresistors

Figure 5:- Gives the representation of photovoltaic solar panel servo motor, photoresistors.

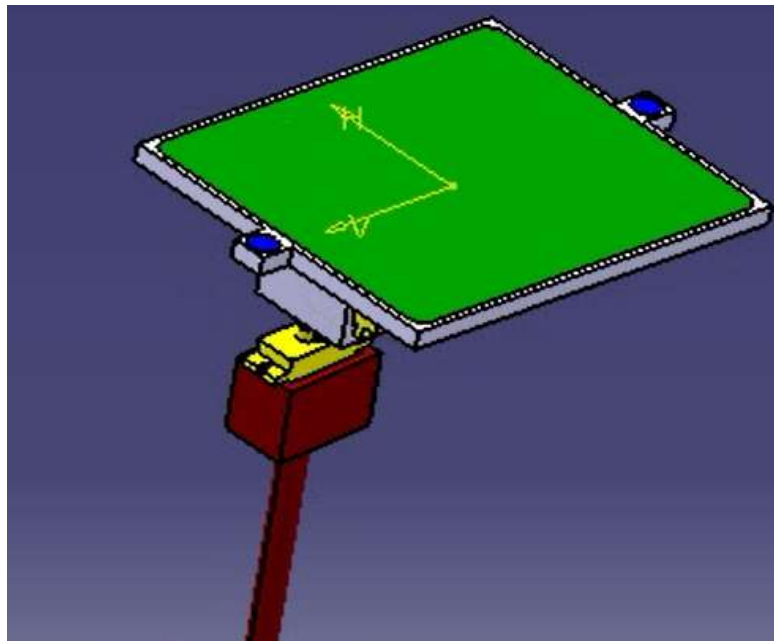
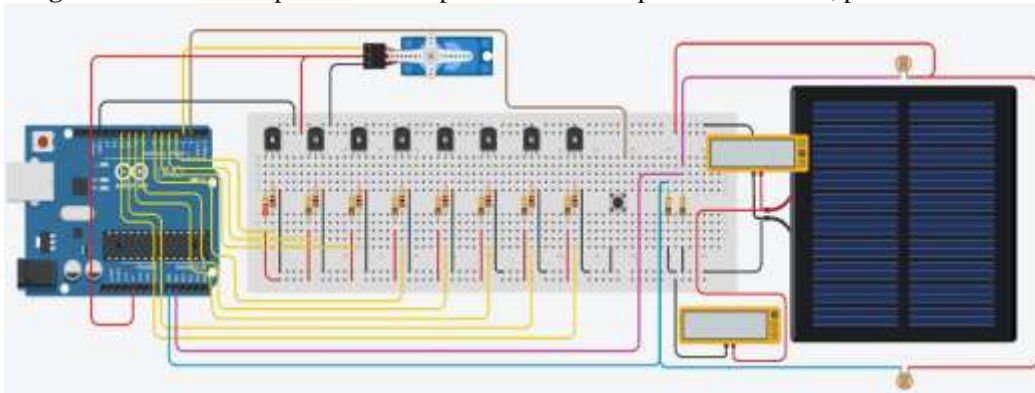

Figure 3:- Control of the programming of the solar panel device.

Acquisition system

The ATmega microcontroller processes the system's operating information (data) [13,14].

The computer present in the device allows to upload the operating program into the ATmega card and supervise the process.

Electronic Board

The ATmega microcontroller used is pen source, via its digital and analog ports, the controls and loads are activated. The ATmega is connected to the computer via USB cable.

Transistors

The transistors whose charge resistors are connected to its base ensure the combination. With n transistors we will have 2^n combinations. We chose 8 transistors for the combination of loads automatically.

Temperature and humidity sensors

Type K thermocouple measuring photovoltaic solar panel surface and Dht11 ambient temperature and humidity are used in our device.

Review System

A digital oscilloscope is a measuring instrument intended to visualize an electrical signal, often variable over time. It makes it possible to observe temporal variations, either of electrical voltages or of various other physical quantities [13,15]. The oscilloscope is connected in the device to visualize the characteristic I-V curve

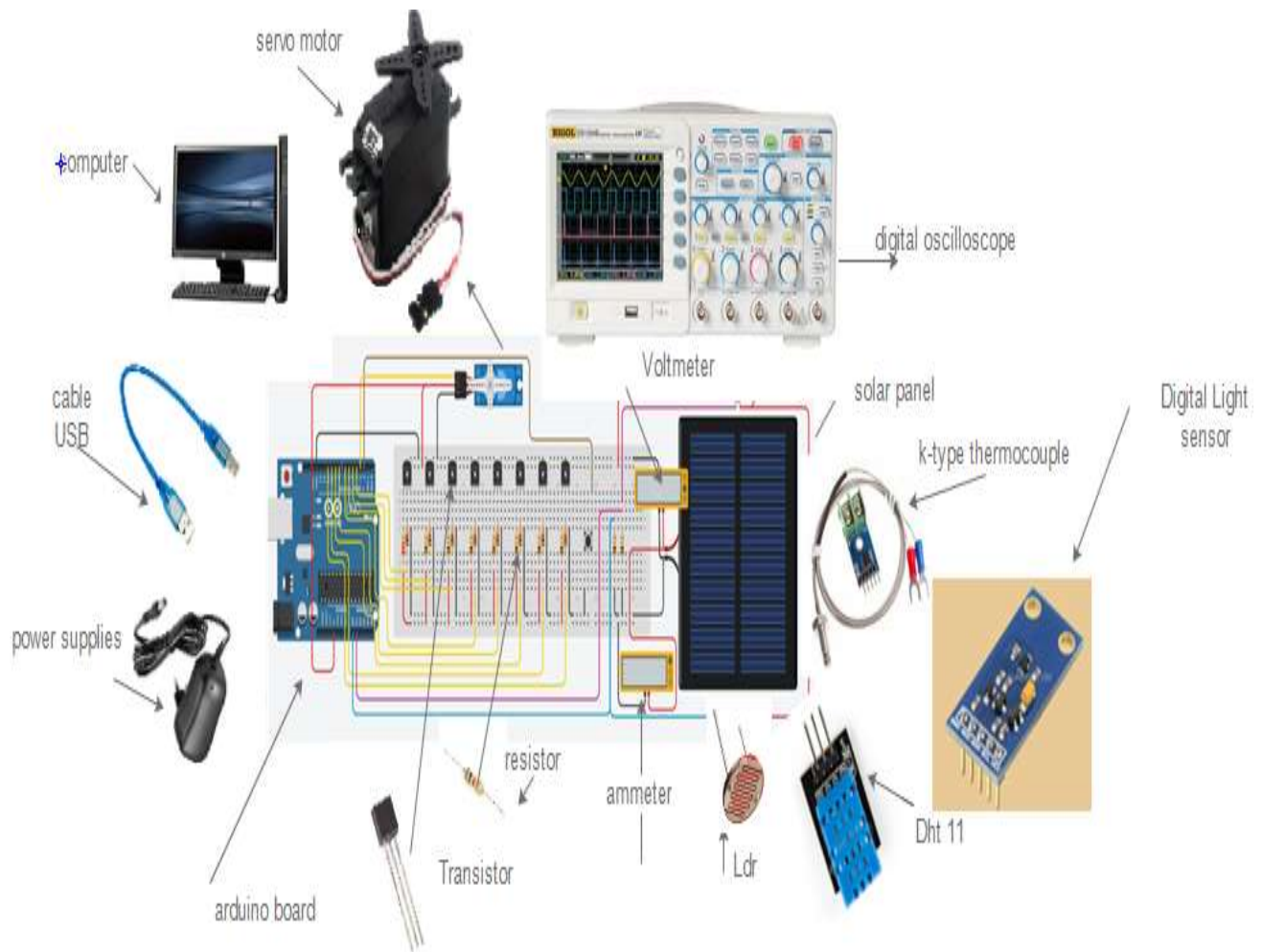

Figure 4:- Presentation of the intelligent electronic solar panel management system [16].



Figure 5:- Photocell solar panel with photoresistance and temperature sensor.

In the device a 200 MHZ digital oscilloscope was placed to visualize the characteristic curve I-V [17] according to the angular deviation of the photovoltaic solar panel.

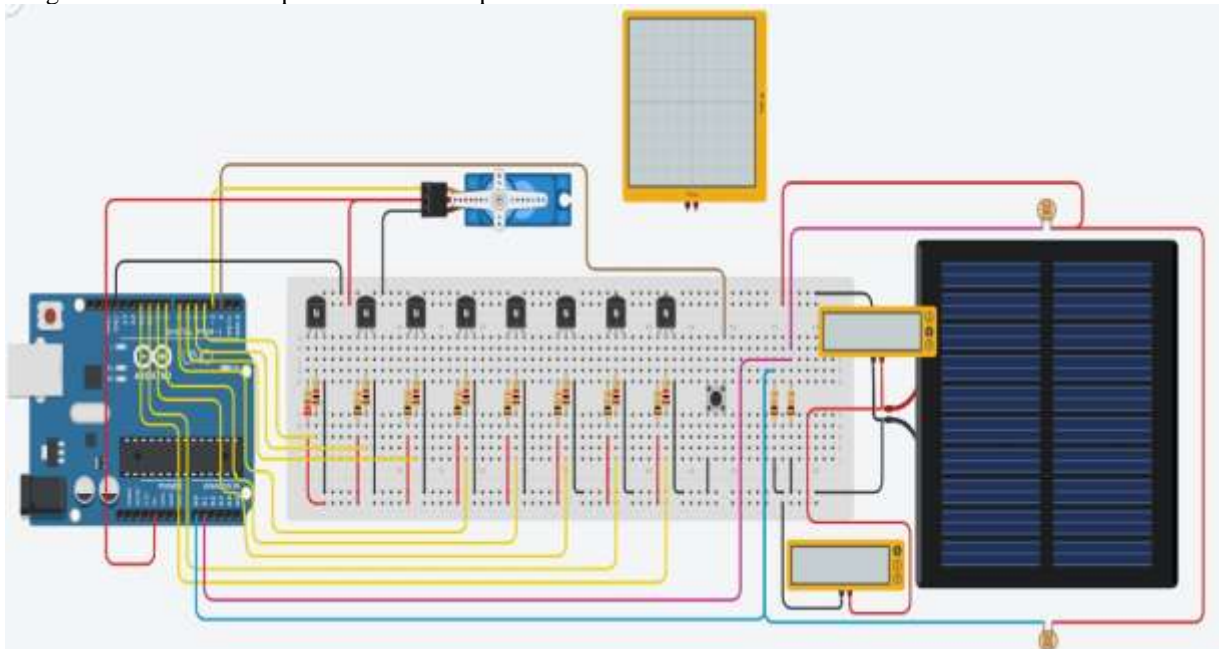

Figure 6:- Solar Panel I-V Digital Display Device.

Temperature and Humidity Scans

The selected Max6675 type k thermocouple temperature sensor does not require calibration to give an accuracy of $\pm 0,5^{\circ}\text{C}$ over a temperature between -20°C and $+85^{\circ}\text{C}$. This sensor is characterized by the equation.

$$V_{cap} = 10mv \times T(11)$$

The type k thermocouple is placed directly on the surface of the PV solar panel. Indeed, the sensor allows us to read the temperature (in degrees and farad) of the photovoltaic cell. The DHT11 sensor provides a digital output proportional to the temperature and humidity measured by the sensor. The technology used to produce the DHT11 sensor ensures high reliability, excellent long-term stability and a very fast response time. The DHT11 is precisely calibrated in the laboratory. The single-wire serial interface enables fast and simple integration of this sensor into the digital system [18]. With this sensor, we receive the data of the ambient temperature and humidity of the medium. In addition, temperature, humidity are analog values. These temperature and humidity values are read from the Arduino software serial monitor [18].

```

1: void setup() {
2:   // put your setup code here, to run once:
3:
4: }
5:
6: void loop() {
7:   // put your main code here, to run repeatedly:
8:
9: }

```

```

12:46:13.442 -> 01111110
12:46:13.442 -> Température dht 11 : 28.30
12:46:13.489 -> Humidité dht 11: 54.50
12:46:13.489 ->
12:46:13.489 -> thermocouple : 16.00 °C
12:46:13.536 -> thermocouple : 60.80 F
12:46:13.536 ->
12:46:13.583 -> Ligne : 127
12:46:13.583 -> 11111110
12:46:13.583 -> Température dht 11 : 28.30
12:46:13.630 -> Humidité dht 11: 54.50
12:46:13.630 ->
12:46:13.630 -> thermocouple : 16.00 °C
12:46:13.676 -> thermocouple : 60.80 F
12:46:13.676 ->
12:46:13.676 -> Ligne : 128

```

Figure 7:- Arduino Serial Monitor.

Both type k thermocouple sensors and the DHT11 are connected to the electronic board, read the data in real time according to the angular position of the photovoltaic solar panel.

Algorigram of the automatic experimental process for the solar panel is thus presented in figure 10.

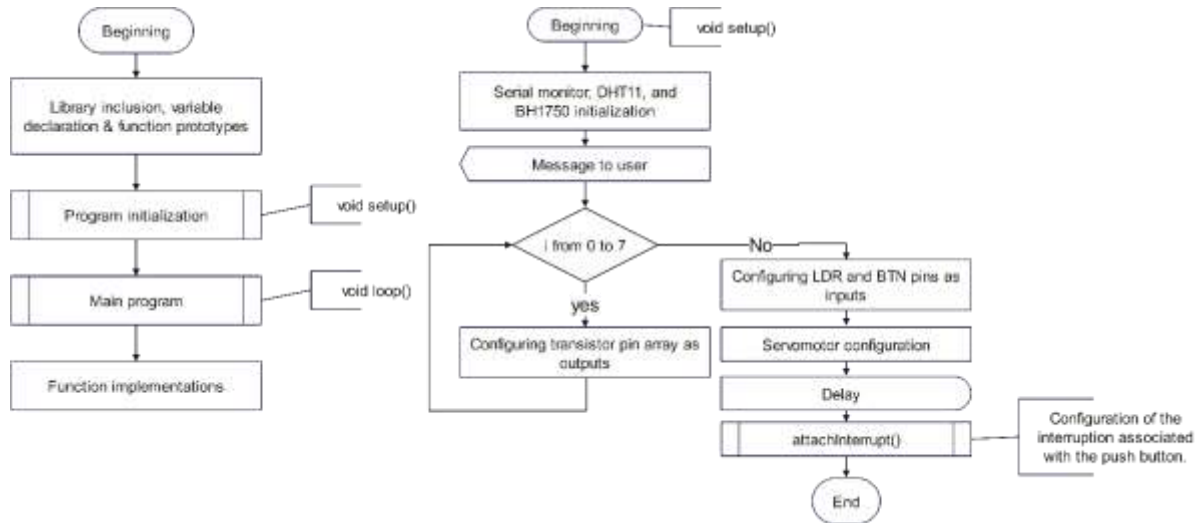

Figure 10:- Algorithmic presentation of the general functioning of the process.

Realization of the experimental device

This work was carried out in the electronic laboratory (of the CEDT "the G15" of Dakar. The assembly of the automatic experimental process placed in the laboratory while the photovoltaic solar panel is placed outside under solar lighting as shown in Figure 9.11

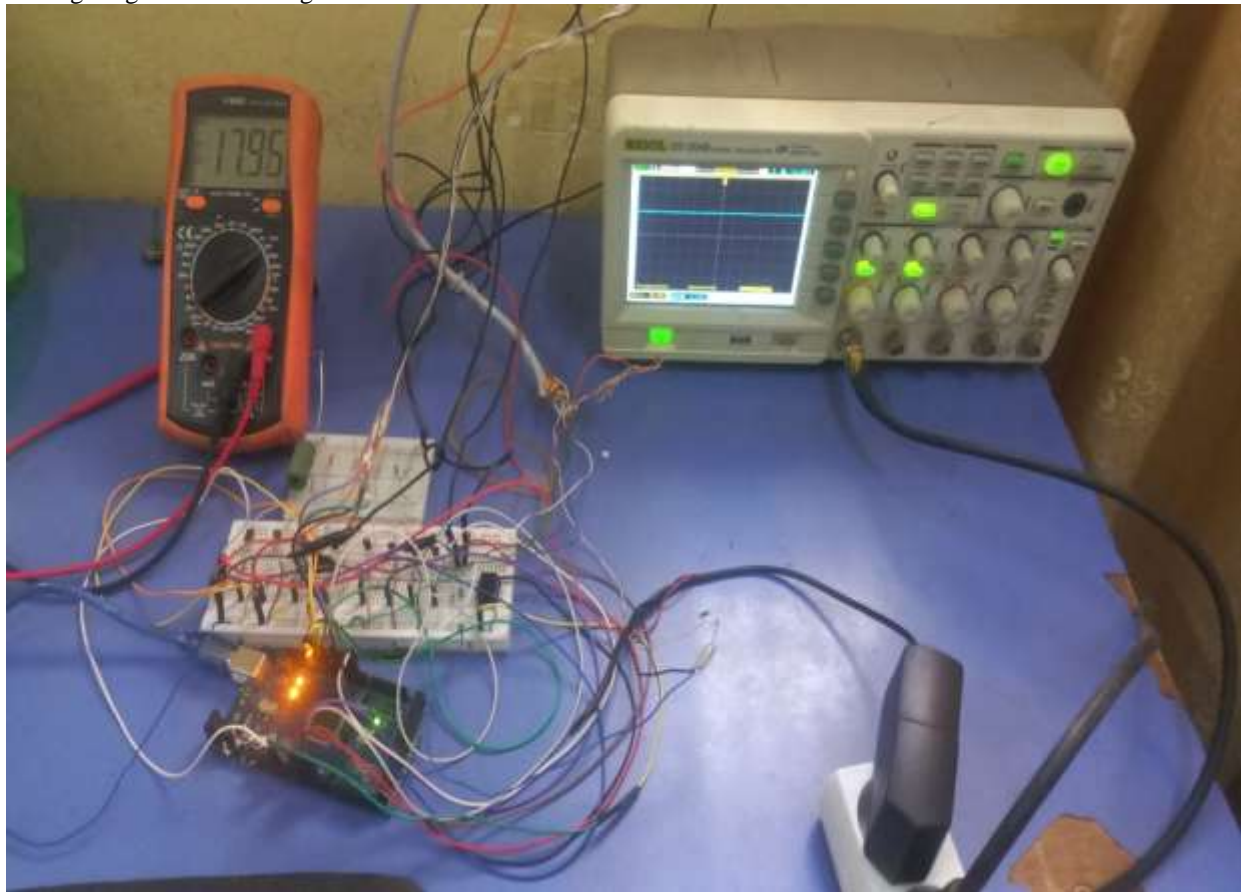

Figure 8:- Intelligent system operation.

Figure 9:- Solar panel under solar lighting.



The results of the experiments

Figure 13 shows the curve of the current and the voltage produced by the photovoltaic panel with the follower system at a position. The observation of the curve highlights the influence of the temperature and the illumination on the electrical quantities of the photovoltaic modules.

The system operating flowchart is shown in Figure 13. The shape of the I-V curve below is obtained and the temperature and humidity data in tables 2 and 3.

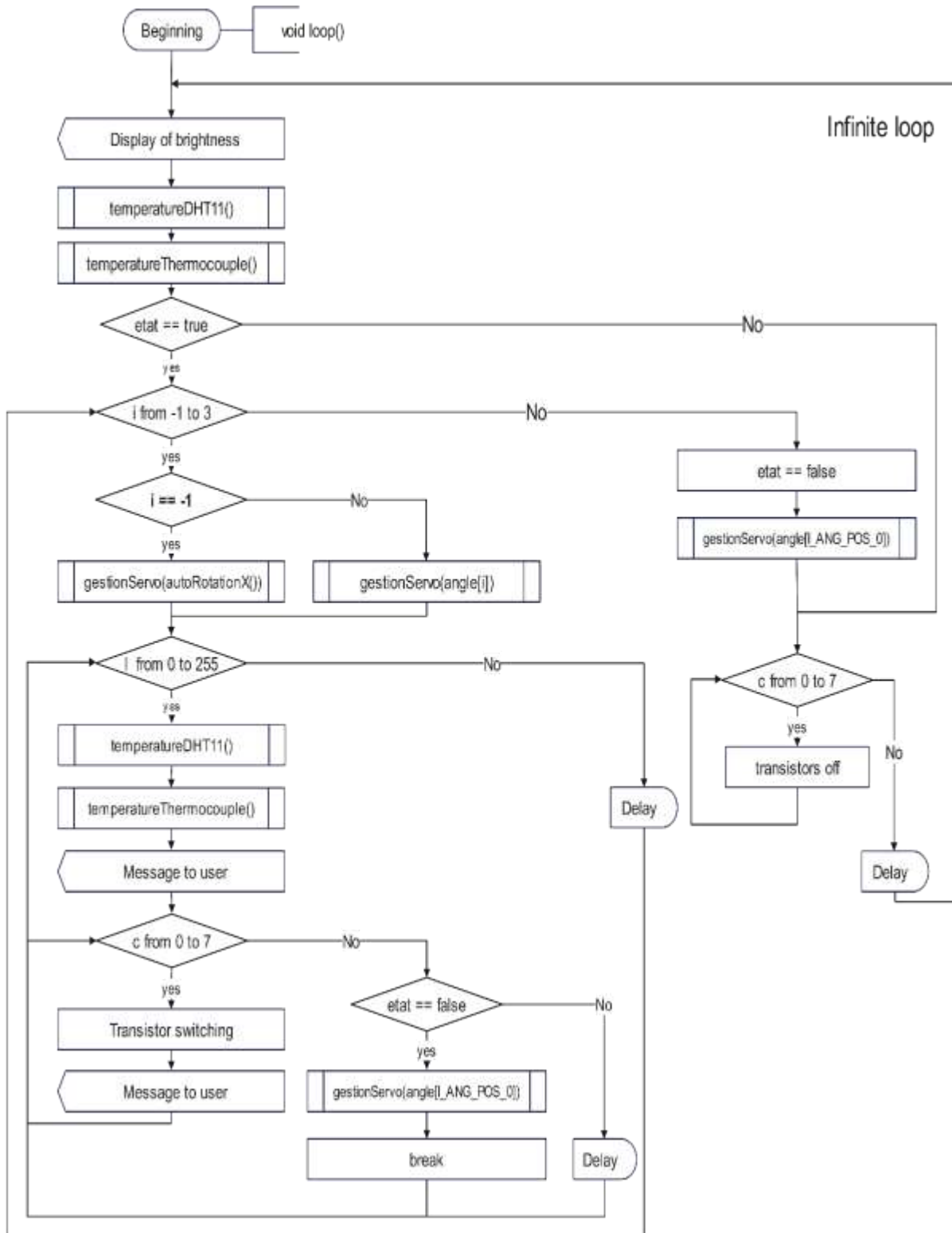

Figure 10:- Automated operation diagram.

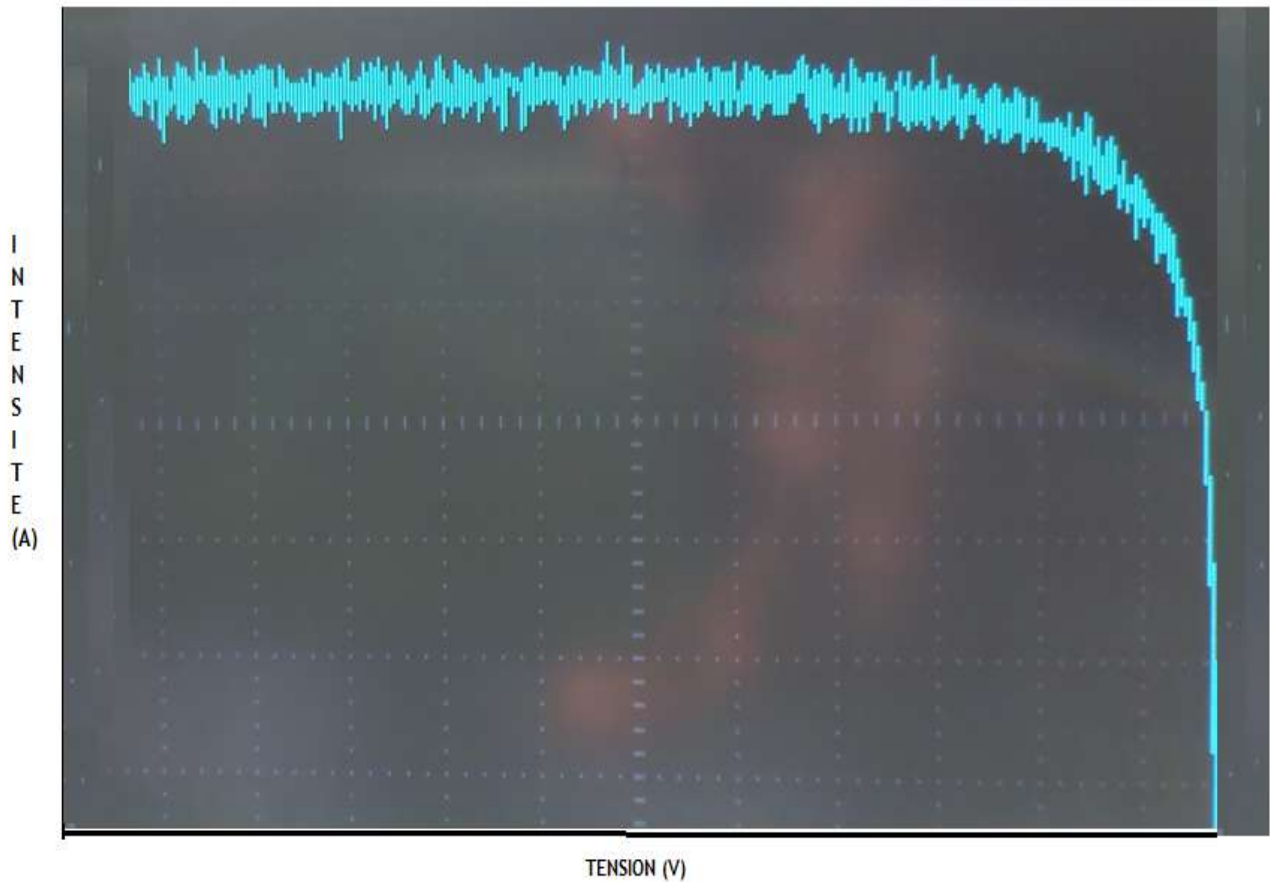

Figure 11:- I-V feature in static mode under illumination.

The temperature on the surface of the photovoltaic panel, humidity and ambient temperature are thus obtained thanks to the sensors bet in the device. Depending on the arbitrarily chosen angular position, 60°, 90°, 120° and the angle of position of the sun, we obtain the results of the following tables.

Table 2:- Temperature and humidity values.

angle of inclination	60°	90°	120°
Ambient temperature in degrees (°C)	34.80	34.40	34
humidity	75	79	74
Panel surface temperature in degrees (°C)	37.50	36.25	37.25
Voc	19.14	19.16	19.4
Jphcc	117mA	111.5mA	111mA

Table 3:- Azimut temperature value.

Tilt angle sun position	120
Ambient temperature in degrees (°C)	39.90
humidity	60
Panel surface temperature in degrees (°C)	38.75
Voc	19.4
Jphcc	111mA

Conclusion:-

The design and implementation of an experimental platform for the solar photocell under influence: use of embedded systems using an ATmega open source microcontroller, two photoresistant sensors, Dht temperature sensors of thermocouple type K, the oscilloscope was used to visualize the characteristic I-V curve of the

photovoltaic solar system. The use of this tracker on the photovoltaic system made it possible to have the panel temperature at different angles chosen arbitrarily in relation to the angle of the sun's position. The automated system allows to accurately visualize the I-V curve as well as the surface temperature of the panel and the ambient temperature, environmental humidity.

References:-

- [1] Mactar Faye, Ababacar Thiam, (2017) Choice of Site for the Installation of Photovoltaic Solar Power Plants in Senegal: Consequences on Electricity Production, *Journal of Power and Energy Engineering*, 2017, 5, 109-118 <http://www.scirp.org/journal/jpee>
- [2] Ousmane Sow, M., Diarisso, D., Saliou Diallo, M. and Mbodji, A. (2013) Experimental Device for Acquisition of Properties I-V and V (T) of the Solar By Automatic Change Operating Point. *International Journal of Innovative Technology and Exploring Engineering (IJITEE)*, 2, 330-334.
- [3] Dialo Diop, Moulaye Diagne, Abel Sambou, Pascal Djicol Bassene, Serigne Abdoul Aziz Niang, Astou Sarr. (2021) Influence of Dust Deposition on the Electrical Parameters of Silicon-Based Solar Panels Installed in Senegal (Dakar Region) *Energy and Power Engineering*, 2021, 13, 174-189 <https://www.scirp.org/journal/epe> ISSN Online: 1947-3818
- [4] G. Sissoko, E. Nanema, A. Correa, M. Adj, A.L. Ndiaye, M.N. Diarra (1998). Recombination parameters measurement in double sided surface field solar cell. *Proceedings of World Renewable Energy Conference, Florence-Italy*, pp. 1856-1859
- [5] O. Diasse, A. Diao, I. Ly, M.S. Diouf, I. Diatta, R. Mane, Y. Traore and G.Sissoko (2018). Back Surface Recombination Velocity Modeling in White Biased Silicon Solar Cell under Steady State. *Journal of Modern Physics*, 9, 189-201. <https://doi.org/10.4236/jmp.2018.92012>
- [6] Abdoulaye DIOP , Richard MANE, Gora DIOP, Ibrahima DIATTA, Khady LOUM, Segala GUEYE, Moustapha THIAME, Ousmane SOW, Mamadou WADE, Gregoire SISSOKO, Bifacial Silicon (N+/P/P+) Silicon Solar Cell Base Thickness Optimization under Back Illumination of Long Wavelength: Effect of Diffusion Coefficient Resonance in Temperature under Applied Magnetic Field *Journal of Scientific and Engineering Research*, 2022, 9(11):152-165
- [7] Maynara A. Aredes, Bruno W. França, Maurício Aredes, Fuzzy Adaptive P&O Control for MPPT of a Photovoltaic Module, *Journal of Power and Energy Engineering*, 2014, 2, 120-129. <http://www.scirp.org/journal/jpee>
- [8] Kuo, Y.-C., Liang, T.-J. and Chen, J.-F. (2001) Novel Maximum-Power-Point-Tracking Controller for Photovoltaic Energy Conversion System. *IEEE Transactions on Industrial Electronics*, 48, 594-601.
- [9] Rahmana, M.M., Hasanuzzaman, M. and Rahim, N.A. (2015.) Effects of Various Parameters on PV-Module Power and Efficiency. *Energy Conversion and Management*, 103, 348-358. <https://doi.org/10.1016/j.enconman.2015.06.067>
- [10] Rahmana, M.M., Hasanuzzaman, M. and Rahim, N.A. (2015.) Effects of Various Parameters on PV-Module Power and Efficiency. *Energy Conversion and Management*, 103, 348-358. <https://doi.org/10.1016/j.enconman.2015.06.067>
- [11] Marie Pascaline Sarr, Ababacar Thiam, Biram Dieng, El Hadji Ibrahima Cisse (2022) Design and Implementation of a low-Cost Mini Heliostat Solar Tracking System in west Africa, *Proceedings of International Conference on Power Electronics and Renewable Energy Systems* pp 193-204
- [12] Hamza Abarchi Halarou, Sani Dan Nomao Harouna, Harouna Souley Ousmane, Daouda Abdourahimoun, and Idrissa Mossi Moctar (2021) [Study and realization of a solar tracker using the Arduino board for a solar photovoltaic installation] *International Journal of Innovation and Applied Studies* ISSN 2028-9324 Vol. 35 No. 1 Dec. 2021, pp. 36-41.
- [13] Diouf, S. , Ndiaye, M. , Thiam, N. , Traore, Y. , Ba, M. , Diatta, I. , Diouf, M. , Mballo, O. , Thiam, A. , Ly, I. and Sissoko, G. (2019) Influence of Temperature and Frequency on Minority Carrier Diffusion Coefficient in a Silicon Solar Cell under Magnetic Field. *Energy and Power Engineering*, **11**, 355-361. doi: 10.4236/epe.2019.1110023.
- [14] B. K. Bose, P. M. Szczesny, and R. L. Steigerwald, "Microcomputer control of a residential power conditioning system," *IEEE Trans. Ind. Applicat.*, vol. IA-21, pp. 1182-1191, Sept./Oct. 1985.
- [15] H. D. Maheshappa, J. Nagaraju, and M. V. Krishna Murthy, "An improved maximum power point tracker using a step-up converter with current locked loop," *Renewable Energy*, vol. 13, no. 2, pp. 195-201, 1998

- [16] Jupiter Ndiaye, Ousmane Sow, Youssou Traore, Mame Andallah Diop, Ababacar Sadikh Faye, Abdoulaye Diop (2022). Electronic System Using Artificial Intelligence for Queue Management. Open Journal of Applied Sciences, 2022, 12,2019-2036 <https://www.scirp.org/journal/ojapps> ISSN Online: 2165-3925
- [17] Dione, B., Sow, O., Wade, M., Ibrahima, L.Y., Mbodji, S. and Sissoko, G. (2016) Experimental Processus for Acquisition Automatic Features of I-V Properties and Temperature of the Solar Panel by Changing the Operating Point. Circuits and Systems, 73984-4000. <http://dx.doi.org/10.4236/cs.2016.711330>-
- [18] Mamadou Sall, Ousmane Sow, Sega Gueye, Gora Diop, Lemrabott Habiboullah, Mamadou Wade, Gregoire Sissoko (2022). Solar Controller with Automatic Search Technology for the Maximum Power Point with Autonomy Display. Energy and Power Engineering, 2022, 14, 509-522 <https://www.scirp.org/journal/epe> ISSN Online: 1947-3818.