



Journal Homepage: - [www.journalijar.com](http://www.journalijar.com)

## INTERNATIONAL JOURNAL OF ADVANCED RESEARCH (IJAR)

Article DOI: 10.21474/IJAR01/13061

DOI URL: <http://dx.doi.org/10.21474/IJAR01/13061>



### RESEARCH ARTICLE

#### SINGLE PHASE REDUCED ORDER AC-AC RESONANT- FREQUENCY CONVERTER

Anukriti Sharma and Navdeep Singh

Electrical Engineering Department, Madan Mohan Malaviya University of Technology, Gorakhpur, India.

#### Manuscript Info

##### Manuscript History

Received: 23 April 2021

Final Accepted: 25 May 2021

Published: June 2021

##### Key words:-

AC-AC Resonant Frequency Converter (AARFC), THD (Total Harmonics Distortion), Trapezoidal Pulse Width Modulation (TPWM)

#### Abstract

This paper presents the performance analysis of proposed circuit of Single-Phase Reduced Order AC-AC Resonant Frequency Converter. AC-AC converter is minimized number of switches for multi-operation and resonant converter is converter work on the principle of ZCS (Zero Current Switching) and ZVS (Zero Voltage Switching) combining both topology, which provide better output with reduce THD and switching losses. A mathematical modeling is done for proper value of used parameters in converter. The output of converter is improved by applying Modulation technique; in this converter we are using Trapezoidal Pulse Width Modulation (TPWM) for the better performance and control. THD of the converter is calculated by using MATLAB simulation software. MATABL simulation of AC –AC Resonate Frequency Converter is done by using MOSFET as switch.

Copy Right, IJAR, 2021,. All rights reserved.

#### Introduction:-

To reduce the harmonics and power losses in power electronic converters different topologies are used and for the better performance studies are keep are going. A Cyclo-converter is the device which is used for converting fixed AC input to variable frequency and voltage. Present market, different Cyclo-converters are available and it has various application areas. An AC-AC multi converter [1] is device which has multiple conversion facility and it can also be used as the Cyclo-converter. AC-AC multi converter consist 2 soft switches and 4 diodes for all mode of operations with mid-point transformer provide isolation between input supply and output circuit. Using one circuit we can able to perform all power electronics operations. AC-AC multi-converter can operate as rectifiers, chopper, and inverters or as variable frequency converter. The converter with modulation, can control and provide desired shape of output but device go through high di/dt due to large load current also having stress due to high voltage and cause electromagnetic interference due to high di/dt and dv/dt by this it has some disadvantages such as high conduction and switches loss and also it has high THD [2] so to eliminate this we proposed modified version of AC-AC multi converter with resonant circuit. Resonant circuit provide better performance and reduced THD and loss for particular converter [3]-[4] resonant force to switches to ON and OFF on ZVS (zero voltage switching) or ZCS (zero current switching), they are forced to pass through zero crossing using inductor and capacitor in it. Resonant converters are mainly used in high application, they provide us limited regulation in output voltage The performance of converters can also be improved using Modulation Techniques [5]-[10] there are different modulation techniques is available for various application [11]. Novelty of this paper is a modified circuit is proposed with resonant element. A detail of study of AARFC is done in section II. In section III operation of converter is discussed. Mathematical modeling of converter is in section IV. Section V is about modulation technique which used in converter for the better output. All the simulations and results are shown in section VI. Analysis of result is done in section VII and finally section VIII concludes all the parameters.

**Corresponding Author:- Anukriti Sharma**

Address:- Electrical Engineering Department, Madan Mohan Malaviya University of Technology, Gorakhpur, India.

### AC-AC Multi Resonant Converter

Single-Phase AC-AC Resonant Frequency Converter (AARFC) is the modified model of AC-AC multi converter [1], AC-AC multi-converter is simple and small size device with multiple application it has some advantages such as it required a smaller number of controllers and Sencer because of less number switches compare to other converter, lower gate complexity and better efficiency but having some limitation like they have high THD around of 60-70 % which cannot be neglected when they used for practical application and also they have high switching and conduction losses in the range of 100-200 watts which should be minimized so, considering all this point a resonant circuit introduced in converter, where inductor and capacitor connected on the output side of circuit to get zero crossing, AARFC is also multi-purpose device as AC-AC multi converter having same component and operation with one extra circuit of L and C and one mode of operation when switch and diode both are not conducting. It can be used for various conversions by applying proper gate signals to the switches accordingly to desired output. AC-AC multi concreteer has THD and losses due this its performance got affected to reduce this different correction can be done by using filters or by applying PWM techniques form one of them a technology is used named resonant converter. This paper gives a detail analysis of AARFC with proper designed and output. The circuit diagram of AARFC is given in Fig. 1. It consists two soft switching (IGBT or MOSFET) with 4 diode and parallel resonate circuit consist inductor and capacitor combination and center tapped transformer with input is AC supply. The center tapped transformer input side winding indicate as w1, output side as w2 and w3 for upper and lower winding respectively

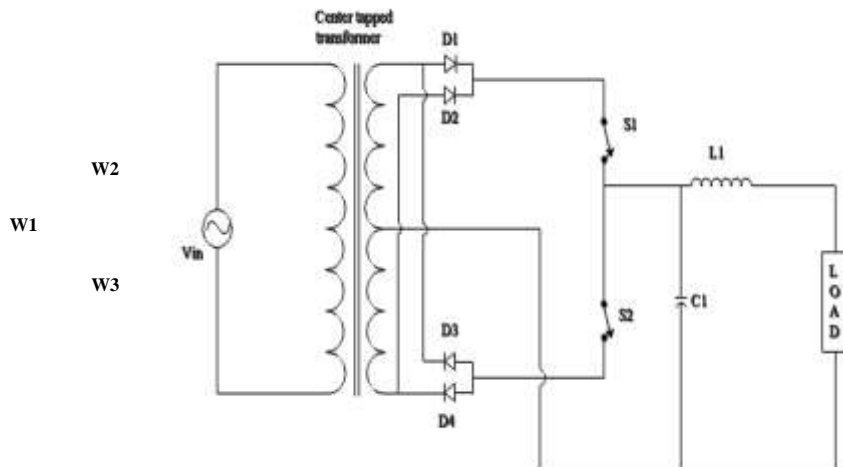

Fig.1:- Circuit diagram of AC-AC Resonant Frequency Converter

### Operating Principle

The (AARFC) has 4 modes of operation when switch is on at any time of instant and the mode where neither switch nor diode are conducting. Let's take an example when input frequency 50Hz and we required output frequency of 100Hz, by using the switching pulse according to switching timing shown in table1. Table 1 shows the state of Switches and diode where ON and OFF states is indicated by 0 and 1, 0 indicates OFF sates and 1 indicates ON state.

#### When the switch is ON

When switch is ON the energy will delivered by source and during this capacitor and inductor will be charge up to it full capacity. All possible 4 modes are shown here;

Mode1:  $0 < t < t_1$

In this mode converter conduct for cycle of 0 to  $\pi$ , the input cycle is positive and sinusoidal in function the S1 (switch) and D1 (diode) will conduct and continued to conduct to  $t_1$ . The current path, T/F winding 2 – D1- S1- load- T/F winding 2.

Mode2:  $t_1 < t < t_2$

In this mode converter conduct for duration of  $\pi$  to  $2\pi$ , input cycle become negative S1 and D2 will conduct. Current path is T/F winding 3 – D2- S1- load- T/F winding 3.the diagram of current flow in mode2.

Mode3:  $t_2 < t < t_3$

In mode3 conduction duration is for  $2\pi$  to  $3\pi$  input cycle become positive again and S2 and D4 will conduct. The path of current is T/F winding 2 – load- S2-D3-T/F winding 2.

Mode4:  $t_3 < t < t_4$

In this mode conduction duration is for  $3\pi$  to  $4\pi$  input cycle become negative, S2 and D3 will conduct for this mode. The Current path, that will be T/F winding3-load-S2-D4- T/F winding3.

**When the switch is OFF**

When the switch is off there is no supply present in the circuit the input side will be as open circuit and in the output side only L, C and load will present. The current continued to load by the energy stored in inductor and capacitor.

**Mathematical Modeling**

For the proposed circuit the mathematical modeling is done here:

**Case 1: When switch is on**

When the switch is on the parameter will defined following, diode and switch is conducting simplified version of fig 1 is shown in fig.2 where  $V_{in}$  is supply of 230 volts at 50 Hz frequency,  $v_c$  is voltage across capacitor with the polarity shown in fig and the  $i_L$  is the current through inductor is start rising from zero, by Appling KVL to input side in fig. 2 we get equation (1)  $v_c$  where is capacitor voltage

$$v_c = V_m \sin \omega t \quad (1)$$

Now apply KVL to output loop, equation (2),  $i_L$  is the current in inductor  $L$  and  $R$  is load.

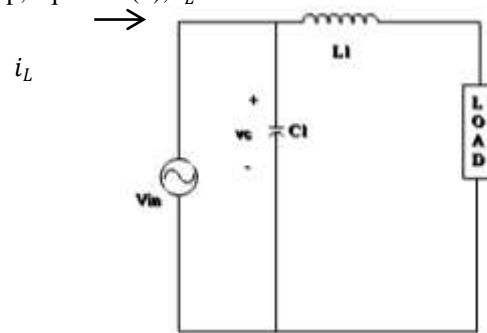

Fig.2:- AARFC when switch is ON.

Table 1:- AARFC switching state.

Operation	Output frequency	T/F winding	switches						Output voltage (Vo)
			S1	S2	D1	D2	D3	D4	
Step down frequency	12.5	2	1	0	1	0	0	0	$V_m \sin \theta$
			0	1	0	0	1	0	$V_m \sin \theta$
		3	1	0	0	1	0	0	$-V_m \sin \theta$
			0	1	0	0	0	1	$-V_m \sin \theta$
	25	2	1	0	1	0	0	0	$V_m \sin \theta$
			0	1	0	0	1	0	$V_m \sin \theta$
3	3	1	0	0	1	0	0	$-V_m \sin \theta$	
		0	1	0	0	0	1	$-V_m \sin \theta$	
Step up frequency	100	2	1	0	1	0	0	0	$V_m \sin \theta$
			0	1	0	0	1	0	$V_m \sin \theta$
		3	1	0	0	1	0	0	$-V_m \sin \theta$
			0	1	0	0	0	1	$-V_m \sin \theta$
	200	2	1	0	1	0	0	0	$V_m \sin \theta$
			0	1	0	0	1	0	$V_m \sin \theta$
		3	1	0	0	1	0	0	$-V_m \sin \theta$
			0	1	0	0	0	1	$-V_m \sin \theta$

$$v_c = L \frac{di_L}{dt} + i_L R \quad (2)$$

Equating from equation (1) to (2) we get

$$V_m \sin \omega t = L \frac{di_L}{dt} + i_L R \quad (3)$$

By solving this equation, we get the inductor current

$$i_L = k e^{-t/\tau} + \frac{V_m}{|Z|} \sin(\omega t - \varphi) \quad (4)$$

Where,

$|Z|$  is, the impedance of circuit defined in (5),  $\varphi$  is delay angle express as the tan inverse of the ratio of inductive reactance to resistance (6).

$$|Z| = \sqrt{R^2 + (\omega L)^2} \quad (5)$$

$$\varphi = \tan^{-1} \frac{\omega L}{R} \quad (6)$$

Time constant of system is given as (7)

$$\tau = \frac{L}{R} \quad (7)$$

$$k = \text{constant}$$

Applying initial conditions at  $\omega t = 0$ ,  $i_L = 0$ , to equation 4 and we will get equation (8)

So,

$$0 = k e^0 + \frac{V_m}{|Z|} \sin(0 - \varphi) \quad (8)$$

By solving this equation, we get the constant value of k (9)

$$k = \frac{V_m}{|Z|} \sin(\varphi) \quad (9)$$

So,  $i_L$  is express as

$$i_L = \frac{V_m}{|Z|} \sin(\varphi) e^{-t/\tau} + \frac{V_m}{|Z|} \sin(\omega t - \varphi) \quad (10)$$

Output voltage is given for this state in equation (10)

$$V_o = V_m \sin \omega t - L \frac{V_m}{|Z|} \left[ -\frac{t}{\tau} \sin(\varphi) e^{-t/\tau} - \omega \cos(\omega t - \varphi) \right] \quad (10)$$

### Case 2: When switch is off

When the switch is off the charged voltage now supply the current to load, apply KVL to fig. 3 we get  $v_c$  capacitor voltage (11), defining capacitor voltage in term of current and putting in (11), equation (12) will form.

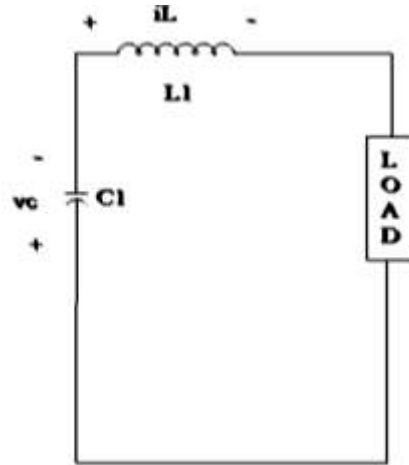

Fig.3:- AARFC when switch is OFF.

$$v_c = L \frac{di_L}{dt} + i_L R \tag{11}$$

$$-\frac{1}{C} \int i_L dt = L \frac{di_L}{dt} + i_L R \tag{12}$$

By arranging equation (12) we will get

$$\frac{1}{C} \int i_L dt + L \frac{di_L}{dt} + i_L R = 0 \tag{13}$$

Differentiating the equation w.r.t time we get

$$\frac{1}{C} i_L + L \frac{d^2 i_L}{dt^2} + \frac{di_L}{dt} R = 0 \tag{14}$$

$$\frac{d^2 i_L}{dt^2} + \frac{di_L}{dt} \frac{R}{L} + \frac{1}{CL} i_L = 0$$

Solution of the following equation is given as

$$i_L = e^{-t/\tau} [A \cos \omega t + B \sin(\omega t)] \tag{15}$$

At  $\omega t = 0, i_L = 0$  putting these values to equation (15) we will get the value of constant A (17)

$$0 = e^{-0} [A \cos 0 + B \sin 0] \tag{16}$$

$$A=0 \tag{17}$$

And at  $\omega t = \pi/2, i_L = i_{Lmax}$ , value of B is given in (19)

$$i_{Lmax} = e^{-\pi/2\tau} (B \sin \pi/2) \tag{18}$$

$$B = i_{Lmax} e^{-\pi/2\tau} \tag{19}$$

To minimize the THD and losses switching is done at resonant  
So,

$$X_C = \frac{X_L}{X_L^2 + R^2} \tag{20}$$

$$\frac{1}{2\pi f C} = \frac{2\pi f L}{2\pi f L^2 + R^2}$$

$$2\pi f C = \frac{2\pi f L^2 + R^2}{2\pi f L}$$

By solving and rearranging the above equation the capacitor value is give as in (21)

$$C = \frac{(2\pi fL)^2 + R^2}{(2\pi f)^2 L} \tag{21}$$

For the output frequency  $f_o = 100\text{Hz}$ , let  $R = 10\ \Omega$  and  $L = 150\text{mH}$  then the capacitor value will be  $1470\ \mu\text{F}$

**Trapezoidal Pulse Width Modulation**

In power electronics different modulation technique is available to improve the performance and efficiency of converter such as PWM (pulse width modulation), SPWM (sinusoidal pulse width modulation), TPWM (Trapezoidal Pulse Width Modulation) and 3HIPWM (3<sup>rd</sup> harmonics injection method). SPWM is commonly used, but it has some drawbacks like low fundamental components thus an advance modulation technique is used in the proposed converter that is TPWM. The pulse is generated by comparing trapezoidal reference pulse (frequency is same as output frequency) with triangular carrier signal of frequency 1k-10k Hz. The trapezoidal wave formed by limiting the triangular wave with some value it defined by flat portion ( $2\phi$ ) express in equation 22. Modulation index (M) is given as equation 23. Generated gate pulse is shown in fig 4

$$2\phi = (1 - \sigma)\pi \tag{22}$$

$$A_{trp} = \pm \sigma A_{tri}(\text{max}) \tag{23}$$

Where  $A_{tri}(\text{max})$  = triangular wave amplitude  
 $A_{trp}$  = trapezoidal wave amplitude  
 $\sigma$  = triangular factor  
 The modulation index M is

$$M = A_{trp} / A_{car} \tag{21}$$

$A_{car}$  = Carrier wave amplitude

$A_{car}$   
 $A_{trp}$

g

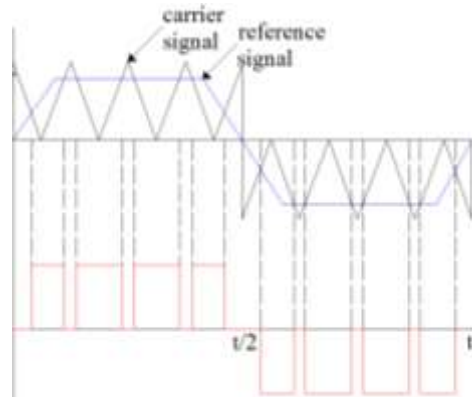

**Fig 4:-** Generated pulse for o/p frequency of 100Hz.

**Vi.Simulation**

All the simulations are performed on MATLAB software using Simulink model and for the switches MOSFET is used with power diode and liner mid-pint transformer all parameter values are given as standard values or from table2. Value of L and C is calculated by mathematical modeling for the different frequencies. The calculation for THD is done by using MATLAB. The modulation techniques used is Trapezoidal Pulse Width Modulation by which the harmonic is reduced. For the TPWM carrier frequency is taken 10 kHz with 0.9 modulation index.

(v)

**Table 2:-** Simulink model parameters.

Parameters	Values
Input Supply Voltage (Vin)	230 Volt
Input Supply Frequency (fin)	50 Hz
Load Resistance (R)	10 Ω
Resonant Capacitor (C1)	1470μF (for Step up frequency) 470μF (for step down frequency)
Resonant Inductor (L1)	150mH (for step up frequency) 15mH (for step down frequency)

(v)

Output wave for different frequency shown below, fig 5 shows the waveform of frequency 200 Hz, output frequency of 12.5 Hz shown in fig 6, whereas the waveform of frequency 25 Hz and 100 Hz shown in fig 7 and fig 8. For all the results the input frequency is 50 Hz.

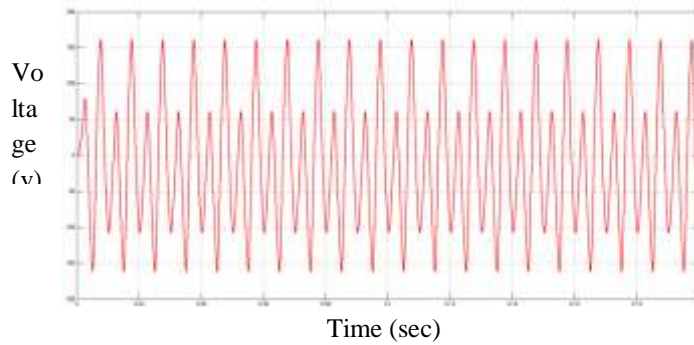

Fig 5:- AC-AC Resonant Frequency Converterwith output frequency 200Hz.

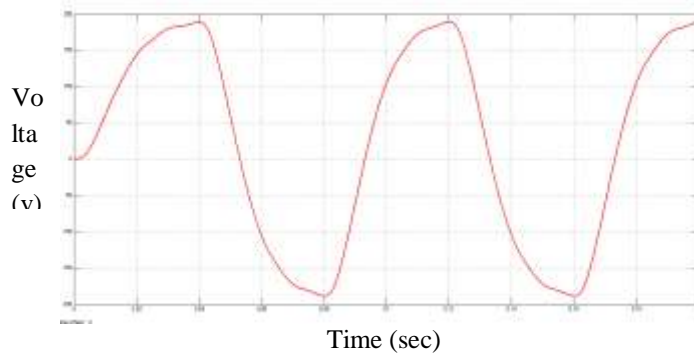

Fig 6:- AC-AC Resonant Frequency Converterwith output frequency 12.5Hz.

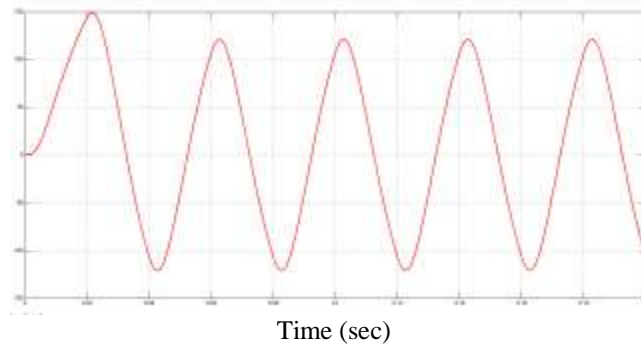

Fig 7:- AC-AC Resonant Frequency Converterwith output frequency 25Hz.

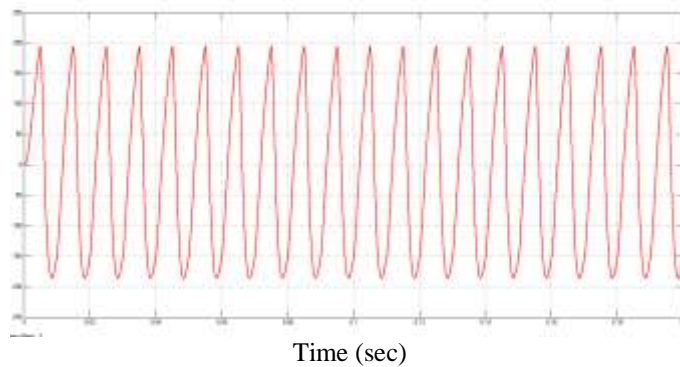

Fig 8:- AC-AC Resonant Frequency Converterwith output frequency 100Hz.

Trapezoidal pulse width modulation technique is applied in AC-AC multi resonant converter and the THD for frequencies 200Hz, 25 Hz ,12.5 Hz and 100Hz are 37.62%, 25.92%, 22.92% and 22.35% shown in fig 9-fig 11. Trapezoidal Pulse width modulation is performed in converter the gate pulses is generated by comparing trapezoidal signal of magnitude  $\pm 0.7$  ( $A_{ref}$ ) to triangular carrier with magnitude of 1unit. Frequency of carrier is 10 kHz. By TPWM we able to reduce the THD with significant amount and also its able to remove 5<sup>th</sup> and 7<sup>th</sup> harmonics in converter and almost zero high order harmonics components.

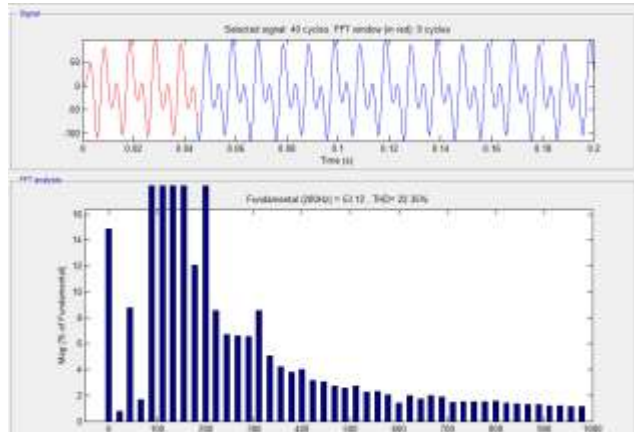

Fig 9:- THD of AC-AC Resonant Frequency Converterwith TPWM at output frequency 200 Hz.

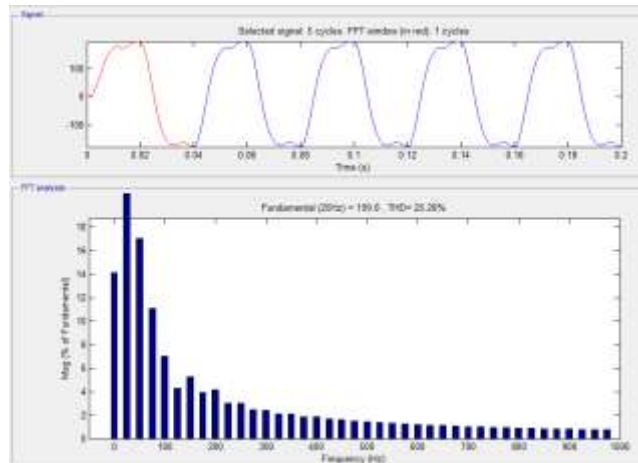

Fig 10:- THD of AC-AC Resonant Frequency Converterwith TPWM at output frequency 25 Hz.

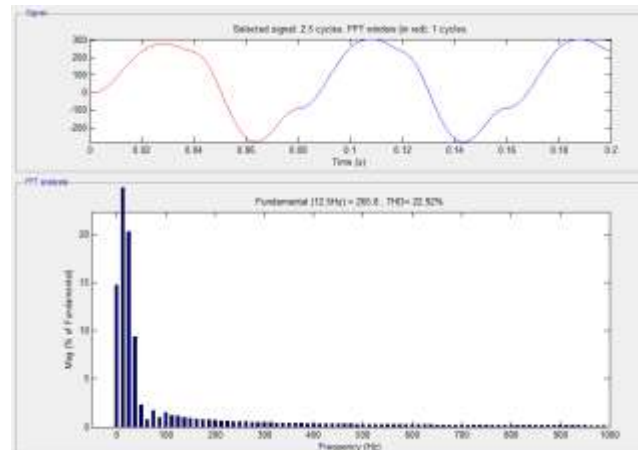

Fig 11:- THD of AC-AC Resonant Frequency Converterwith TPWM at output frequency 12.5Hz.



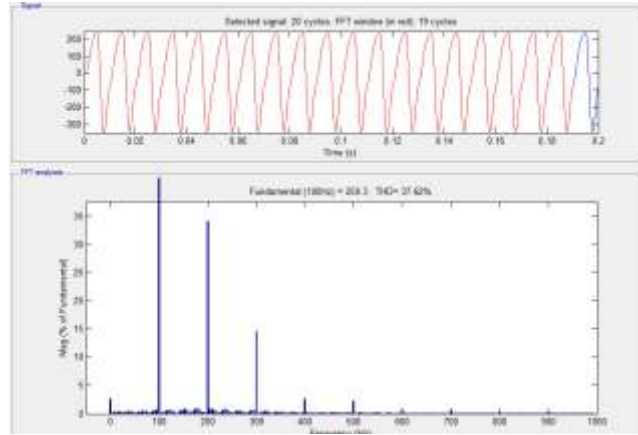

Fig 12:- THD of AC-AC Resonant Frequency Converter with TPWM at output frequency 100 Hz

**Analysis**

The performance of AARFC is shown above section, with and without modulation for different frequencies the THD of converter shown in table 3. resonant converter is show very better result compare to another converter the THD is in the range of 20-30% and by using modulation we can able to reduce this range to 10-25%. By the chart 1 we can easily see the results are very effective and better.

Table 3:- AARFC THD Analysis.

Frequency	AARFC	
	Without any Modulation	TPWM
12.5	22.95	21.54
25	25.62	18.61
100	27.04	22.10
200	24.13	18.51

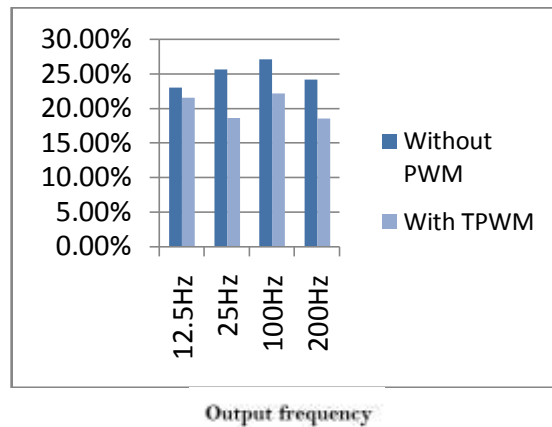

Fig 13:- Total harmonics distortion comparison chart.

**Conclusion:-**

A performance single-phase AC-AC Resonant Frequency Converter with simple and compact size having resonant circuit has been proposed. The proposed single-phase AC-AC Resonant Frequency Converter can use as higher/ lower frequency conversion of input voltage depending on the switching. The converter is compact, simple and less complex gate designed and modeling of converter is done which not so difficult. The proposed single-phase AARFC uses the Trapezoidal Modulation technique as controlling method for better performance. Thus, the control circuit in proposed AARFC is easy to design with low cost. Converter has resonant unit, which work on zero crossing switching during ON and OFF condition. Thus, the converter has less switching losses, THD, and higher efficiency

is achieved with this topology. Total harmonic distortion (THD) of converter is reduced very much and by using TPWM the THD able to reduce to 10-25 %.

#### **Rferencece:-**

- [1] MD. HalimMondol, MD. ShihabUddin, EklasHossain, and ShuvraProkashBiswas “A Compact and Cost Efficient Multiconvert for Multipurpose Applications”, IEEE Access, vol. 8, pp. 86810-86821, May 2020.
- [2] AmmarFalahAlgamluoli, “Total Harmonic Distortion of Single Phase Mid-Point Cycloconverter Comparison between MOSFET, IGBT and Power Devices”,International Journal of Computer Applications (0975 – 8887),Volume 181 – No. 35, January 2019
- [3] Chien-Ming Wang, Chi-Hsiang Cheng, and Bo-Han Wu “A Single-Stage Series-Resonant Transformer Isolated AC-AC Converter”,13th IEEE Conference on Industrial Electronics and Applications(ICIEA),pp. 1039-1042, 2018
- [4]Mayank Kumar, PreetiAgarwal, and VineetaAgarwal, “A Novel Soft Switched Cycloinverter”, IEEE Transactions on Industrial Electronics , VOL. 62, NO. 1, JANUARY
- [5] G.Aarthil and T.Porselvi2, “Modeling and Simulation of Single Phase Matrix Converter Using PWM”, International Conference on Computing, Electronics and Electrical Technologies (ICCEET), pp 168-173, 2012
- [6] Agarwal, V. Agarwal, “Analysis of AC to AC converter by sinusoidal pulse width modulation (SPWM) and delta modulation (DM) technique,” Proceedings of Third Power Engineering and Optimization Conference, Jun. 2009
- [7] VineetaAgarwal, Anupum Kumar, “Modified PWM Scheme for Cycloinverter”, 8<sup>th</sup> International Power Engineering Conference , pp. 655-660, 2007
- [8] VinitRanjan, Navdeep Singh, Vijay P Singh and Shashi B Singh, “Commutation problem of Single Phase Matrix Converter with PWM dead time technique”, IEEE International Conference on Power Energy, Environment & Intelligent Control (PEEIC), 2018
- [9] 2015VineetaAgarwal, Anupam Kumar, Rhythm Singh and Robin T.J “Modifed PWM Schemes for Cyclo-inverters”,InternationalPower Engineering Conference (IPEC),pp 655-660
- [10] P.Naveenchandran, Vijayaraghavan, “Modulation Techniques in Switching Devices”, International Journal of Pure and Applied Mathematic, Volume 116 No. 13, pp. 137-142, 2017 A.
- [11] Bayindir N.S., Kukrer O., Yakup M.: DSP-based PLL-controlled 50–100 kHz 20 kW high-frequency induction heating system for surface hardening and welding applications, IEEE Proceedings - Electric Power Applications Vol 150 no 3, pp. 365-371 2007.