



Journal Homepage: - [www.journalijar.com](http://www.journalijar.com)

## INTERNATIONAL JOURNAL OF ADVANCED RESEARCH (IJAR)

Article DOI: 10.21474/IJAR01/18178

DOI URL: <http://dx.doi.org/10.21474/IJAR01/18178>



### RESEARCH ARTICLE

#### STUDY OF PERMANENT MAGNET SYNCHRONOUS MOTOR DEMAGNETIZATION FAULT DETECTION USING SIGNAL ANALYSIS TECHNIQUES

Mohamed A.E. Badawy<sup>1</sup>, Ahmed A.A. Saad<sup>2</sup> and Mostafa M.A. Mohamed<sup>3</sup>

1. Researcher, Automotive Eng. Department, Faculty OF Engineering, Helwan University, Egypt.
2. Professor of Automotive Eng. Department, Faculty of Engineering, Helwan University, Egypt.
3. Lecturer of Automotive Eng. Department, Faculty OF Engineering, Helwan University, Egypt.

#### Manuscript Info

##### Manuscript History

Received: 16 November 2023

Final Accepted: 21 December 2023

Published: January 2024

##### Key words:-

PMSM, MCSA, Demagnetization,  
Faultdetection

#### Abstract

Due to its' obvious advantages, there is no doubt that Electric vehicles are gaining huge popularity. That's due to the advantages of electric vehicles when compared to the traditional ICE vehicles. On the other hand, and as electric vehicles are still machines built by human beings, the EVs have several components that can be faulty and affect the vehicle performance and maybe in some stages lead to severe failures or life threatening. These components are mainly the battery, electric motor and controllers. So, many studies focused on studying the electric vehicles components fault detection in the early stages. In this paper, we will focus on one of the most common motor types, the permanent magnet synchronous motors. One of the common PMSM faults related to the rotor is the demagnetization. This fault will be extensively studied using two of the signal analysis method techniques: the output torque and the stator current signal analysis. Using the MATLAB SimuLink, a complete model of the PMSM will be built and the uniform demagnetization fault will be introduced. Then, a comparison between both torque and current signatures will be presented to put our hands on the ability of these techniques to identify the uniform demagnetization fault.

Copy Right, IJAR, 2024,. All rights reserved.

#### Introduction:-

The electric vehicles have many significant advantages when compared to the traditional ICE vehicles. These advantages include the quietness, the friendly usage, low pollution emission and low maintenance cost. However, as any human built machine, the electric vehicles have several components that can be faulty and affect the vehicle performance and maybe in some stages lead to severe failures or life threatening. Based on these facts, and in order to serve the expansion of the electricvehicles usage, it became a must to researchers to focus on studying the fault diagnosing of the electric vehicles components in earlier stages.

The basic components of the electric vehicles can be classified to three main components: The Battery, the electric motor and the electronic components. The motor is considered to be the prime mover of the electric vehicle, and it has various types such as: DC Brushless motors, Induction motors, Synchronous motors. Among these types, the Permanent Magnet Synchronous Motor (PMSM) is one of the most used motors in the Electric vehicles. The reason

**Corresponding Author:- Mostafa M.A. Mohamed**

Address:- Lecturer of Automotive Eng. Department, Faculty OF Engineering, Helwan University, Egypt.

behind this is its advantages as: high efficiency, high output power to weight and to volume ratio, low noise emissions and easy maintenance and also its ability to achieve high-speed operation and precise torque control. Also the PMSM has a simple structure, small size, light weight and large overload capacity. That also means that the PMSM is compact and has a high torque density and high dynamic performance.

When it comes to the PMSM faults, there are three main fault categories according to the fault nature: Electrical faults, Mechanical faults and Magnetic faults. At the same time, there is a mutual catalytic relationship between them. The demagnetization fault is a unique fault of PMSM. Permanent magnets in the PMSM can be demagnetized by damage to the magnet, a high temperature, large stator currents, large short-circuit currents produced by inverter or stator faults, and the aging of the magnet itself. The main source of this fault is armature reactions. During the normal operation of a PMSM, the stator current produces a reverse magnetic field that constantly resists the magnetic field of the permanent magnet [1].

According to previous studies of the fault diagnosing methods, there are three common categories: The model-based fault diagnosis method, the signal-based method and the knowledge-based method [2]. The main concept of the model-based fault diagnosis method is establishing a model of the motor which contains a specific fault based on physical principles. After that, the model predicted output is compared to the actual output that was detected and accordingly the fault occurrence can be detected. Also we can use the model built in simulation needed in other fault diagnosing methods same as carried out in our research. This method can penetrate the internal laws and physical nature of motor faults. However, the disadvantage of this method is that it requires a very accurate motor mathematical model [3]. On the other hand, the Knowledge-based methods can automatically detect the fault occurrence based on the expert knowledge, but this requires extensive expert experience. In addition to this point, and due to the extensive research in artificial intelligence and machine learning, many data-driven intelligent diagnosis algorithms have been proposed recently. These algorithms do not rely on prior knowledge. These methods mainly include the neural network, support vector machine, sparse representation, deep learning and so on. With the data-driven intelligent diagnosis algorithms, the fault type and severity of the motor can be automatically identified by the input data based on the given training data [4].

Accordingly, the signal-based fault diagnosing methods are widely used, especially in the field of fault diagnosing of the PMSM. The reason behind that is the fast, ease of usage and also that method does not require a specific model. The working strategy of this model is collection and processing the motor signatures and comparing these signatures in healthy models with faulty models. Of course, these signatures can be current, vibration, noise, heat, etc [5]. Usually, vibration signatures are used in mechanical bearing fault diagnosing [6]. However, this diagnosis method is not efficient in diagnosing the demagnetization fault. So, the motor current signature analysis (MCSA) fault diagnosing method is the most common fault diagnosing method between the signal analysis techniques. That's due to its ability to diagnose all PMSM fault types [7].

In previous studies of the PMSM faults and diagnosing methods, many researchers studied the PMSM mathematical model in the (abc) stationary reference frame [8,9]. However, this reference frame has to be converted to the (dq0) rotating reference frame to study the output parameters of the motor including the output torque and rotational speed [10,11]. To accomplish this transformation, the Park transformation matrix is used [12,13].

In this research, a complete mathematical model of the healthy PMSM will be built. This model will also include the uniform demagnetization fault input parameters to simulate a faulty PMSM. Afterwards, a MATLAB model will be established with all the needed simulation blocks. Then, a comparison between the torque and the current signatures will be performed to study the effect of the uniform demagnetization on both signatures. That will put hands on the ability of every signature analysis method to detect the presented fault.

#### **Mathematical Model:-**

Basically, the three phase PMSM consists of a stator and a rotor. The stator is a set of windings creating a rotating magnetic field. That field results in the rotor, which is an earth magnet, rotation with respect to the Magnetomotive force concept. The rotational speed of the rotor will be according to the stator alternating current frequency. This speed is also defined as the synchronous speed.

**Healthy PMSM model:**

The healthy model layout consists of three coils or windings, one for each phase of the three phases. The coils here have equal resistances and number of turns per coil. The equation of the healthy PMSM is illustrated below [9, 14].

$$v_{abc} = R_s i_{abc} + \frac{d\lambda_{abc}}{dt} \quad (1)$$

$$\lambda_{abc} = L_s i_{abc} + \lambda_{pm} \quad (2)$$

Where  $v_{abc}$  is the phase voltage 3x1 matrix,  $R_s$  is the 3x3 diagonal matrix describing the resistance of the winding,  $i_{abc}$  is the phase current 3x1 matrix,  $\lambda_{abc}$  is the stator flux linkage 3x1 matrix,  $L_s$  is the 3x3 stator inductance matrix and  $\lambda_{pm}$  is a 3x1 matrix containing mover's flux linkage produced by the permanent magnets.

The abovementioned equations (1) and (2) represent mathematical model of the PMSM in stationary frame known as the (abc) reference frame. However, when we deal with the PMSM as a motor with a value of power, torque and rotational speed, we have to convert the (abc) stationary frame to another rotating frame known as the (dq0) reference frame [15,16]. This is carried out using the Park transformation matrix [17].

The Park transformation matrix is a transformation set of equations to convert the (abc) stationary reference frame model of the PMSM to a (dq0) rotating reference frame model. This conversion is carried out to make a simple dynamic reference frame model that ease the study and analysis of the PMSM performance. The Park transformation (P) matrix is mentioned in the following equation:

$$P = \frac{2}{3} \begin{bmatrix} \cos(\theta_e) & \cos\left(\theta_e - \frac{2\pi}{3}\right) & \cos\left(\theta_e + \frac{2\pi}{3}\right) \\ -\sin(\theta_e) & -\sin\left(\theta_e - \frac{2\pi}{3}\right) & -\sin\left(\theta_e + \frac{2\pi}{3}\right) \\ 0.5 & 0.5 & 0.5 \end{bmatrix} \quad (3)$$

Where  $\theta_e$  is the electrical angle defined as  $N\theta_r$ , where N is the number of pole pairs. When we apply the Park transformation to the (abc) model to the phase voltage matrix, the (dq0) model of the PMSM will be as the followings:

$$v_d = R_s i_d + \frac{d\lambda_d}{dt} - \omega_e \lambda_q \quad (4)$$

$$v_q = R_s i_q + \frac{d\lambda_q}{dt} + \omega_e \lambda_d \quad (5)$$

Where  $v_d$  is the d-axis stator voltage,  $v_q$  is the q-axis stator voltage,  $i_d$  and  $i_q$  are the d-axis stator current and the q-axis stator current, respectively,  $\lambda_d$  and  $\lambda_q$  are d-axis stator magnetic flux linkage and the q-axis stator magnetic flux linkage, respectively and  $\omega_e$  is the rotor electrical angular velocity. The d-axis and q-axis stator magnetic flux linkages are expressed as the followings:

$$\lambda_d = L_d i_d + \lambda_m \quad (6)$$

$$\lambda_q = L_q i_q \quad (7)$$

Where  $L_d$  and  $L_q$  are the d-axis and q-axis inductances, respectively. When you apply these equations to the stator voltage equations (4) & (5), we get the following equations:

$$v_d = R_s i_d + L_d \frac{di_d}{dt} - N\omega_m L_q i_q \quad (8)$$

$$v_q = R_s i_q + L_q \frac{di_q}{dt} + N\omega_m (L_d i_d + \lambda_m) \quad (9)$$

The stator current equations are:

$$\frac{di_d}{dt} = \frac{v_d}{L_d} - \frac{R_s i_d}{L_d} + N\omega_m \frac{L_q}{L_d} i_q \quad (10)$$

$$\frac{di_q}{dt} = \frac{v_q}{L_q} - \frac{R_s i_q}{L_q} - \frac{N\omega_m (L_d i_d + \lambda_m)}{L_q} \quad (11)$$

Knowing that the permanent magnet flux linkage  $\lambda_m$  is fixed. Accordingly,  $\frac{d\lambda_m}{dt}$  is Zero. And the rotor electrical angular velocity  $\omega_e$  equals  $N\omega_m$  where  $\omega_m$  is the rotor mechanical angular velocity.

The electromagnetic torque equation of the PMSM in the dq0 reference frame can be expressed as the following:

$$T_e = \frac{3}{2} N (\lambda_d i_q - \lambda_q i_d) \quad (12)$$

$$T_e = \frac{3}{2} N [\lambda_m + (L_d - L_q) i_d] i_q \quad (13)$$

Where  $T_e$  is the electromagnetic torque. The PMSM speed equation in the dq0 reference frame is as follows:

$$\frac{d\omega_e}{dt} = \frac{N}{J} (T_e - T_L - B\omega_m) \quad (14)$$

Where J is the moment of inertia,  $T_L$  is the load torque and B is the viscous friction coefficient. Also, you can express the electromagnetic torque as a combination of the load torque and the moment of inertia of the motor as the following:

$$T_e(t) = T_L(t) + J \frac{d\omega_e}{dt}(t) \tag{15}$$

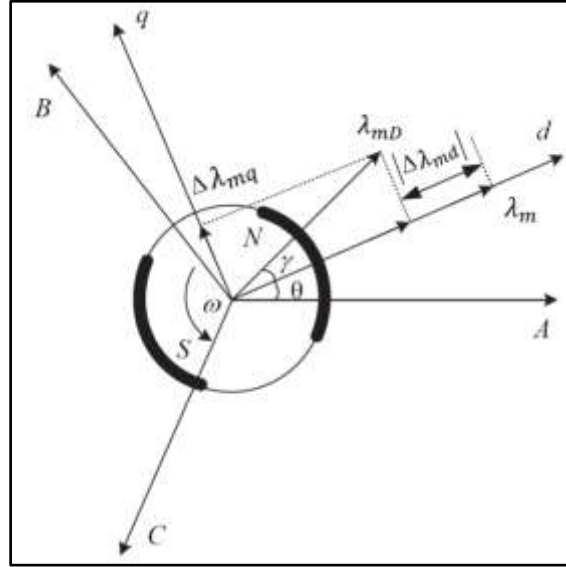

Figure (1):- Variation of the PMSM flux linkage.

**PMSM with Demagnetization fault model:**

As clarified previously, the magnetic fault that is related to the PMSM is the demagnetization of the permanent magnets of the rotor. When demagnetization happens, the flux linkage of the permanent magnet will have a variation in the amplitude and direction. Figure (1). shows the variation of the flux linkage of the permanent magnet from  $\lambda_m$  to  $\lambda_{mD}$  [18,19]. Accordingly, the d-axis stator magnetic flux linkage  $\lambda_d$  and the q-axis stator magnetic flux linkage  $\lambda_q$  will change to the followings:

$$\lambda_d = L_d i_d + \lambda_m + \Delta\lambda_{md} \tag{16}$$

$$\lambda_q = L_q i_q + \Delta\lambda_{mq} \tag{17}$$

Where  $\Delta\lambda_{md}$  and  $\Delta\lambda_{mq}$  can be expressed as the followings:

$$\Delta\lambda_{md} = \lambda_{mD} \cos \gamma - \lambda_m \tag{18}$$

$$\Delta\lambda_{mq} = \lambda_{mD} \sin \gamma \tag{19}$$

Based on these variations, the d-axis and q-axis stator voltages will also change to the followings:

$$v_d = R_s i_d + L_d \frac{di_d}{dt} - N\omega_m L_q i_q + \frac{d(\lambda_m + \Delta\lambda_{md})}{dt} - N\omega_m \Delta\lambda_{mq} \tag{20}$$

$$v_q = R_s i_q + L_q \frac{di_q}{dt} + N\omega_m (L_d i_d + \lambda_m + \Delta\lambda_{md}) + \frac{d\Delta\lambda_{mq}}{dt} \tag{21}$$

But the time constant in the mechanical system is too large compared to the time constant in the electrical system.

So,  $\frac{d(\lambda_m + \Delta\lambda_{md})}{dt} = 0$  and also  $\frac{d\Delta\lambda_{mq}}{dt} = 0$ . So, the equations will be as the following:

$$v_d = R_s i_d + L_d \frac{di_d}{dt} - N\omega_m L_q i_q - N\omega_m \Delta\lambda_{mq} \tag{22}$$

$$v_q = R_s i_q + L_q \frac{di_q}{dt} + N\omega_m (L_d i_d + \lambda_m + \Delta\lambda_{md}) \tag{23}$$

$$\frac{di_d}{dt} = \frac{v_d}{L_d} - \frac{R_s i_d}{L_d} + N\omega_m \frac{L_q}{L_d} i_q + N\omega_m \frac{\Delta\lambda_{mq}}{L_d} \tag{24}$$

$$\frac{di_q}{dt} = \frac{v_q}{L_q} - \frac{R_s i_q}{L_q} - \frac{N\omega_m (L_d i_d + \lambda_m + \Delta\lambda_{md})}{L_q} \tag{25}$$

The electromagnetic torque will be as the following:

$$T_e = \frac{3}{2} N (\lambda_d i_q - \lambda_q i_d) \tag{26}$$

$$T_e = \frac{3}{2} N [(\lambda_m + (L_d - L_q) i_d) i_q + \Delta\lambda_{md} i_q - \Delta\lambda_{mq} i_d] \tag{27}$$

### Motor Current Signal Analysis:

The Motor current signal analysis (MCSA) method is one of the most common signature analysis techniques to diagnose any fault in the PMSM. It is simply the study of the current signature of the power supply to the stator. The principle of this method is to extract the current signature of a stator and carry out processing to the wave using one of the signal analysis methods such as: Fast Fourier Transform, Short Time Fourier Transform, Wavelet transform, etc. Figure (2) simplifies the basic motor current signature analysis method.

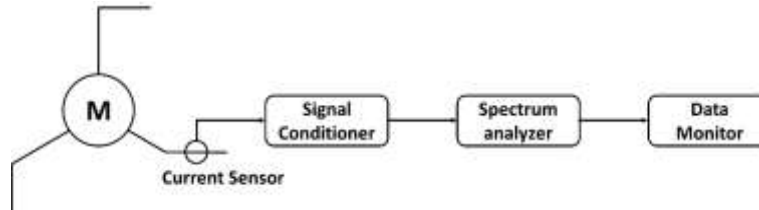

Figure (2):- Motor current signature analysis chart.

### Matlab Model:-

When it comes to the MATLAB model, and to build an accurate model of the PMSM, many specifications and working parameters are needed. Therefore, we used the Schneider Electric BMP0701F3NA2A motor. It is a 0.5 HP 3-phase permanent magnet synchronous motor. Keeping in mind that the model built can be applied on any 3-phase permanent magnet synchronous motor regardless the motor size, specifications, or power. As the motor specifications and parameters will affect the healthy model output. However, the effect of the faults on the healthy motor current will be the same for any motor type. Below you can find the complete BMP0701F3NA2A motor model specifications and working parameters in Table (1).

Table (1):- The BMP0701F3NA2A motor model technical specifications and working parameters.

Rated power	0.5 HP
Rated torque	2 Nm
Operating frequency	100 Hz
Number of pole pairs	3
Winding inductance	40.03 mH
Rotor inertia	0.59 kg.cm <sup>2</sup>
Stator coil resistance	17.75 Ohm
Permanent magnet flux	0.25 Wb
Viscous friction coefficient	11*10 <sup>-5</sup> N.s/rad

The MATLAB model can be broken down to three basic constructing model groups:

- a- The healthy PMSM model which contains the representation of all mathematical equations of the PMSM without adding any fault.
- b- The simulation blocks and these are divided into two sub-groups.
  - i. The current analysis simulation blocks that use the inverse Park transformation matrix to get the (abc) reference frame back from the (dq0) model to extract the motor currents for analysis.
  - ii. The output Torque block that contains the needed torque signal monitor for the torque signal analysis of the fault.
- c- The Fault simulation block: This block simulates the terms of the Demagnetization fault. To add the Demagnetization fault to the healthy model of PMSM, all we have to do it setting the value of the Fault actuation constant from "0" to "1".

The Demagnetization fault will require a block that is simulating the  $\Delta\lambda_{md}$  and  $\Delta\lambda_{mq}$  as in equations (18 & 19). To make the simulation easier with few fault parameters, we assumed the new flux linkage of the permanent magnet is 0.2 Wb and the angle of the new flux linkage of the permanent magnet  $\gamma$  is 45°.

Accordingly:

$$\lambda_{mD} \cos \gamma = \lambda_{mD} \sin \gamma = 0.1414 \text{ Wb} \quad (28)$$

After we assume the new fault parameters, the Demagnetization fault MATLAB block of  $\Delta\lambda_{md}$  and  $\Delta\lambda_{mq}$  will be as shown in Figures (3) & (4).

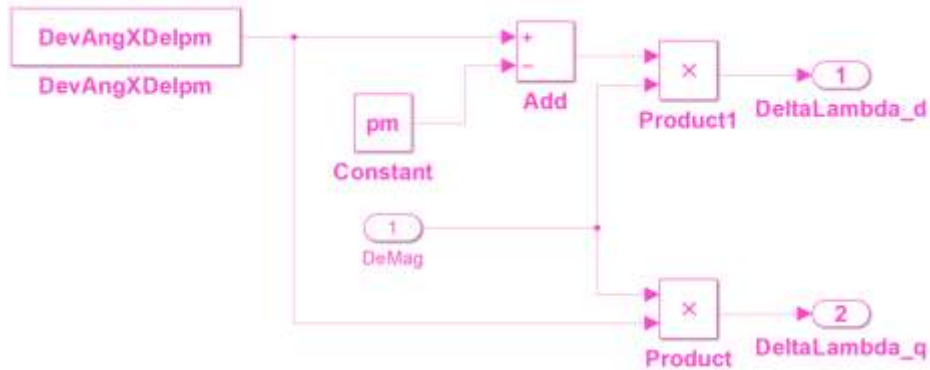

Figure (3):-  $\Delta\lambda_{md}$  and  $\Delta\lambda_{mq}$  block.

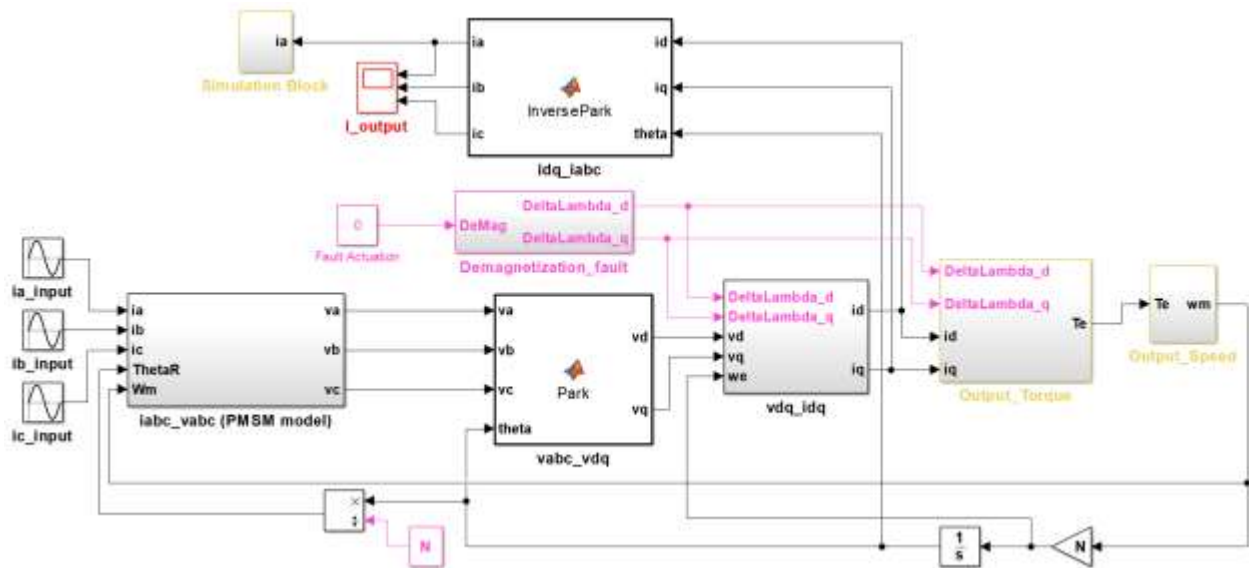
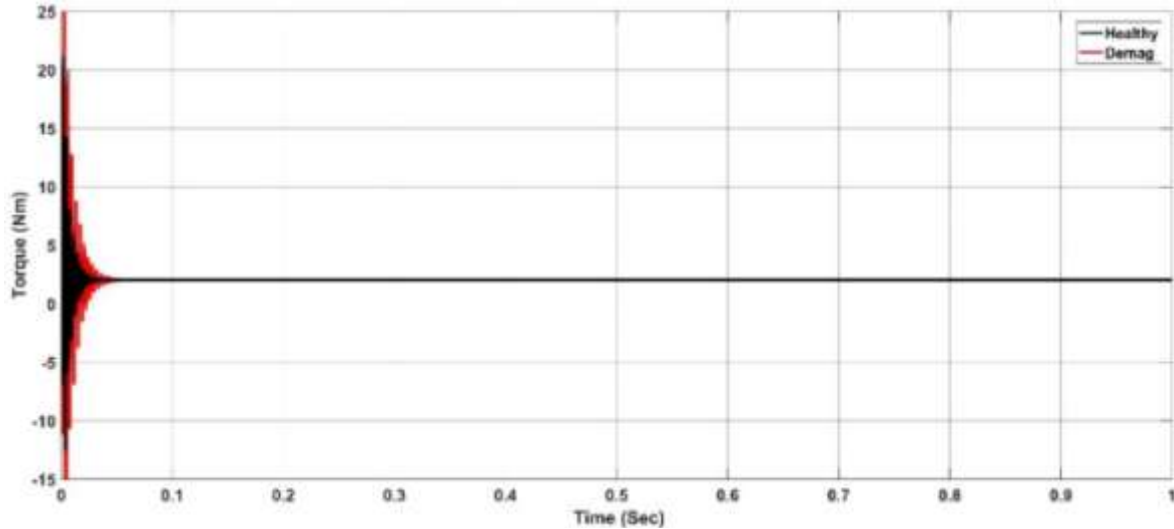

Figure (4):- The complete MATLAB model.

**Results and Discussion:-**

After building the complete mathematical and MATLAB models, we will focus in our research on comparing the torque signature differences between the healthy and faulty PMSM model and also the current signature in one of the three phases of the supplied current. According to the previous studies, the demagnetization fault has a clear effect on the torque. Because of the ripple of the flux linkage, the output torque of the PMSM will decrease and be insufficient. Accordingly, the PMSM will consume more current to overcome the torque shortage. In other words, the demagnetization fault results in lack of output torque. Accordingly, the stator current signature amplitude increases to produce more torque to compensate for the torque absence. That means that the uniform demagnetization will have no effect on the torque signature of the motor. To verify this estimation, both torque and current signatures were extracted from the MATLAB model in two cases: Healthy and faulty PMSM. Figure (5) shows the torque signature of the PMSM with no fault and with Demagnetization fault.



**Figure (5):-** Torque signature of the PMSM in both Healthy and Faulty states.

You can see the symmetry between the steady accurate output torque value of the motor in both cases. The reason for this is there are no change in the torque load of the motor. However, when it comes to the current signature of the motor, you can easily see the effect of the uniform demagnetization fault on the current signature of the PMSM. The noticed effect is an increase in the amplitude of the current signal of the stator and this effect will be noticed in all phases of the power supply.

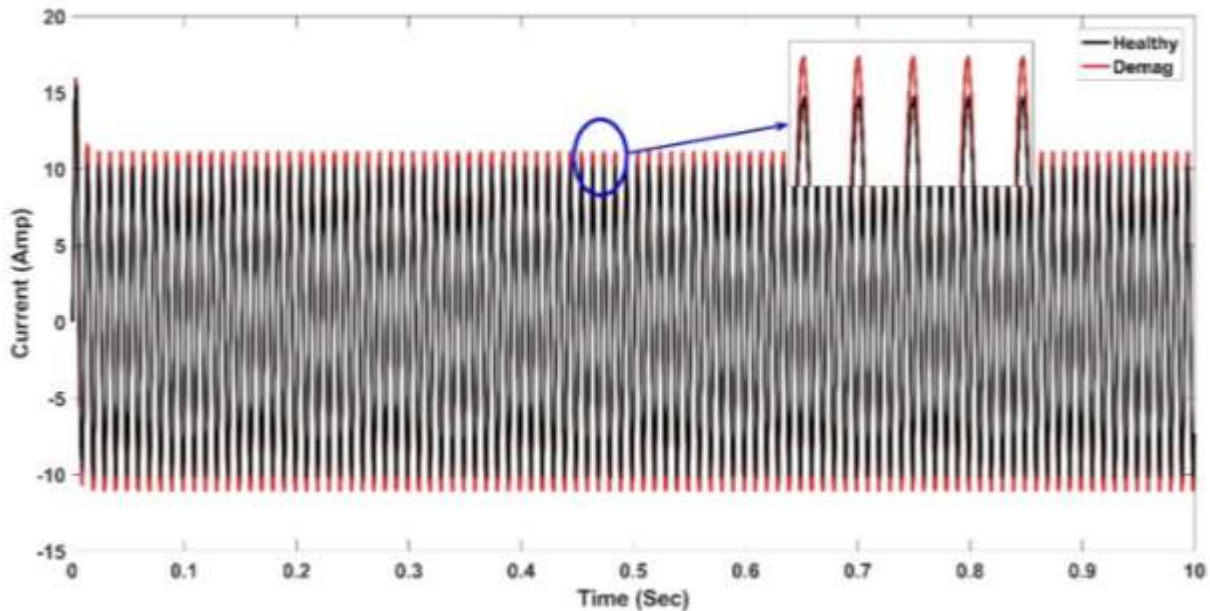

**Figure (6):-** Current signature of the PMSM in both Healthy and Faulty states.

Figure (6) shows the current signal of the PMSM stator in two states: one with healthy PMSM and the other with uniform demagnetization fault.

### Conclusion:-

The demagnetization is one of the main faults related to the permanent magnet synchronous machines. This fault manipulates the flux linkage direction and amplitude. Accordingly, there will be lack of output torque which is compensated by increasing the stator current consumed. A complete MATLAB model was built to simulate the PMSM in healthy state and the demagnetization fault was simulated. Afterwards, the torque and the current signatures were extracted in both healthy and faulty conditions. It was noticed that the torque signature doesn't have

the ability to diagnose the uniform demagnetization fault. However, the demagnetization fault has a significant effect on the rotor current signature represented by an increase in the current amplitude.

### References:-

1. Yong C., Siyuan L., Wanfu L., Hong L., Chengdong W. et al., Faults and Diagnosis Methods of Permanent Magnet Synchronous Motors: A Review, *Applied Sciences* 9(10):2116, 2019, doi:10.3390/app9102116.
2. Zhiwei G., Carlo C. and Steven X. D., A Survey of Fault Diagnosis and Fault-Tolerant Techniques—Part II: Fault Diagnosis With Knowledge-Based and Hybrid/Active Approaches, *IEEE Transactions on Industrial Electronics*, Volume: 62, Issue: 6, June 2015, doi:10.1109/TIE.2015.2419013.
3. Zia Ullah and Jin H., A Comprehensive Review of Winding Short Circuit Fault and Irreversible Demagnetization Fault Detection in PM Type Machines, *Energies* 11(12):3309, 2018, doi:10.3390/en11123309.
4. Y. Zhongming and Wu B., A review on induction motor online fault diagnosis, 3rd International Power Electronics and Motion Control Conference, 2000, doi:10.1109/IPEMC.2000.883050.
5. Dubravko M., Brief Review of Motor Current Signature Analysis, presented at HDKBR info, 15 (2015), Croatia, April 29, 2015.
6. Ferhat Ç., Müslüm A., Bilal G. and Taner G., Analysis of stator inter-turn short-circuit fault signatures for inverter-fed permanent magnet synchronous motors, *IEEE Industrial Electronics Society 42nd Annual Conference*, October 2016, doi:10.1109/IECON.2016.7793717.
7. Fengyang G., Guoheng Z., Mingming L., Yunbo G. et al., Inter-turn Fault Identification of Surface-Mounted Permanent Magnet Synchronous Motor Based on Inverter Harmonics, *Energies* 13(4):899, 2020, doi:10.3390/en13040899.
8. Najla H. O., Thierry B. and Babak N. M., Modeling and diagnostic of incipient inter-turn faults for a three phase permanent magnet synchronous motor using wavelet transform, *IEEE Industry Applications Society Annual Meeting*, October 2015, doi:10.1109/IAS.2015.7356845.
9. S. Moosavi, Q. Esmaili, A. Djerdir and Y. Amirat, Inter-Turn Fault Detection in Stator Winding of PMSM Using Wavelet Transform, *IEEE Vehicle Power and Propulsion Conference (VPPC)*, 2017, doi:10.1109/VPPC.2017.8330891.
10. Bashir M. E., Mehrgan J. R., Jawad F. and Seyed V. K., Advanced Eccentricity Fault Recognition in Permanent Magnet Synchronous Motors Using Stator Current Signature Analysis, *IEEE Transactions on Industrial Electronics*, Volume: 61, Issue: 4, April 2014, doi:10.1109/TIE.2013.2263777.
11. Mohammad R. M., Norman M., Mahdi K., Samsul B. M. N. et al., Wavelet-Based Analysis of MCSA for Fault Detection in Electrical Machine, 2015, doi:10.5772/59743.
12. Zheng A. P., Yang J. and Wang L., Fault Detection of Stator Winding Interturn Short Circuit in PMSM Based on Wavelet Packet Analysis, *5th International Conference on Measuring Technology and Mechatronics Automation*, January 2013, doi:10.1109/ICMTMA.2013.141.
13. J. Urresty, J. Riba, L. Romeral, J. Rosero et al., Stator short circuits detection in PMSM by means of Hilbert-Huang transform and energy calculation, *IEEE International Symposium on Diagnostics for Electric Machines, Power Electronics and Drives*, October 2009, doi:10.1109/DEMPED.2009.5292789.
14. Muhammad C., and John F., *Advanced Direct Thrust Force Control of Linear Permanent Magnet Synchronous Motor Reference Book*, (2020), 13-43, doi:10.1007/978-3-030-40325-6.
15. Jianmin Z., Zhonghua W., Dongxue W., Yueyang L. et al., Review of fault diagnosis of PMSM drive system in electric vehicles, *36th Chinese Control Conference (CCC)*, July 2017, doi:10.23919/ChiCC.2017.8028529.
16. Manuel A. M., Guillermo R. B., C. H. De Angelo and D. R. Espinoza-Trejo, A Model-Based Strategy for Interturn Short-Circuit Fault Diagnosis in PMSM, *IEEE Transactions on Industrial Electronics*, Volume: 64, Issue: 9, September 2017, doi:10.1109/TIE.2017.2688973.
17. Colm J., Mohammad Q., Matthew O. and James K., A Geometric Interpretation of Reference Frames and Transformations: dq0, Clarke, and Park, *IEEE Transactions on Energy Conversion*, 2019, doi:10.1109/TEC.2019.2941175.
18. Changfan Zhang, Gongping Wu, Fei Rong, Jianghua Feng, Lin Jia, Jing He and Shoudao Huang, Robust Fault-Tolerant Predictive Current Control for Permanent Magnet Synchronous Motors Considering Demagnetization Fault, *IEEE Transactions on Industrial Electronics*, Volume: 65, Issue: 7, July 2018, doi:10.1109/TIE.2017.2774758.
19. Kaihui Zhao, Tonghuan Yin, Changfan Zhang, Jing He, Xiangfei Li, Yue Chen, Ruirui Zhou and Aojie Leng, Robust Model-Free Nonsingular Terminal Sliding Mode Control for PMSM Demagnetization Fault, *IEEE Access*, Volume: 7, January 2019, doi:10.1109/ACCESS.2019.2895512.