



Journal Homepage: - www.journalijar.com

INTERNATIONAL JOURNAL OF ADVANCED RESEARCH (IJAR)

Article DOI: 10.21474/IJAR01/20561

DOI URL: <http://dx.doi.org/10.21474/IJAR01/20561>



RESEARCH ARTICLE

LEVERAGING MICROSTRIP ANTENNAS FOR EARLY-STAGE TESTICULAR CANCER DIAGNOSIS: A REVIEW

N. Sheshaprasad¹ and Kiran K.N²

1. Professor, Department of Electronics and Communication, BNM Institute of Technology, Bengaluru.
2. Assistant Professor, Department of Electronics and Communication, BNM Institute of Technology, Bengaluru.

Manuscript Info

Manuscript History

Received: 08 January 2025

Final Accepted: 12 February 2025

Published: March 2025

Key words:-

Microstrip Antenna, Testicular Cancer Detection, Non-Invasive Cancer Detection, Early Cancer Detection, Sensitivity and Specificity, Biological Tissue Properties, Penetration Depth, Metamaterials, Multi-Frequency Antenna Design, Machine Learning, Clinical Trials, Wearable Devices, Point-of-Care Testing

Abstract

Microstrip antennas offer a compelling possibility for non-invasive testicular cancer detection due to their compact, lightweight, and cost-effective nature. Simulations enable optimizing their design for this application. However, challenges remain, including achieving sufficient sensitivity and specificity to distinguish between healthy and cancerous tissues. Additionally, biological tissue complexities and limited penetration depth at optimal frequencies requires further exploration. This work highlights the potential of microstrip antennas in testicular cancer screening. Future research areas include advanced antenna designs, multimodal approaches incorporating other imaging techniques, and machine learning for data analysis. Rigorous clinical trials are crucial to validate the method's efficacy and safety in real-world settings. The objective is to leverage microstrip antennas to develop a reliable, user-friendly tool for early detection of cancer, potentially improving the patient outcomes by means of early intervention.

"© 2025 by the Author(s). Published by IJAR under CC BY 4.0. Unrestricted use allowed with credit to the author."

Introduction:-

Testicular cancer is a relatively rare form of cancer that primarily affects young men. Early detection of this form of cancer is crucial for successful treatment and improved patient outcomes [1]. Current screening methods for testicular cancer include physical examination, blood tests (such as tumor markers), and imaging studies (such as ultrasound). However, it is observed that these methods have potential limitations related to accuracy, invasiveness, and cost. With an aim to address these pertinent challenges, researchers have been exploring alternative methods for testicular cancer detection, including the utilization of microstrip antennas.

Microstrip antennas are compact, lightweight, and low-cost antennas that can be integrated into wearable devices or medical implants. These antennas operate at microwave frequencies and may be used to detect changes in tissue properties associated with the presence of testicular cancer [1]. Microstrip antennas offer the potential for non-invasive and cost-effective testicular cancer detection, with high sensitivity and specificity.

By transmitting and receiving microwave signals, microstrip antennas can measure the dielectric properties of testicular tissue and detect abnormalities that may point towards the presence of cancer. The use of microstrip

Corresponding Author:- N. Sheshaprasad

Address:- Professor, Department of Electronics and Communication, BNM Institute of Technology, Bengaluru.

antennas for testicular cancer detection could revolutionize the field of oncology by providing a non-invasive and efficient means for early detection, allowing for timely intervention and improved patient outcomes.

The proposed approach could potentially overcome the limitations of current screening methods and provide a more accurate and accessible means of detecting testicular cancer at an early stage. The development of technology specifically for detecting testicular cancer at the initial stages is considered crucial for improving patient outcomes and survival rates. The use of microstrip antennas for testicular cancer detection is a promising approach that could revolutionize the field, providing a non-invasive, cost-effective, and accurate method for early detection.

Background overview:-

While there is no extensive research directly on testicular cancer detection using microstrip antennas, a few papers explore microwave techniques for testicular applications [2,3,4,5,6]. The paper [7] explores using a microstrip patch antenna in the early detection of breast cancer. While it focuses on a different cancer type, it provides critical insights regarding the design considerations, simulation process, and potential advantages of this approach in microwave imaging for cancer detection.

This paper [8] delves into the aspects of design for a circular patch microstrip antenna for skin cancer detection. It highlights the role of simulation tools and choosing the appropriate operating frequency based on tissue properties. This paper [9] explores the concept of using a microstrip antenna for skin cancer detection. It emphasizes the analysis of scattering parameters (S-parameters) as a method to distinguish between healthy and cancerous tissues. This paper [10] discusses the application of microstrip patch antennas in breast cancer detection. It highlights the potential benefits of this method, such as being non-invasive and cost-effective.

The Role of Microstrip Antennas in Medical Diagnostics

The chances of survival for a cancer patient mainly depends on early detection. The role of microstrip antennas in medical diagnostics extends beyond just testicular cancer detection. These antennas have shown promise in various fields of medical diagnostics due to their ability to provide non-invasive, cost-effective, and accurate measurements of tissue properties.

When it comes to cancer, early detection is crucial for successful treatment and improved patient outcomes. The use of microstrip antennas for detecting tissue properties changes, associated with the presence of cancer holds the potential to transform the cancer diagnostics techniques. By utilizing microwave frequencies to measure tissue dielectric properties, microstrip antennas offer a new approach to identifying abnormalities associated with cancer.

The potential impact of microstrip antennas in medical diagnostics extends to other types of cancer as well. Their non-invasive nature and ability to provide accurate measurements make them a promising technology for early detection of different types of cancer, ultimately contributing to improved patient outcomes and improved survival rates amongst different cancer types. Furthermore, the integration of microstrip antennas into wearable devices or medical implants opens up possibilities for continuous monitoring and early intervention, which are crucial aspects of managing cancer effectively.

Understanding Testicular Cancer: Causes and Symptoms

In recent years, there is an increased focus on understanding the causes and symptoms of testicular cancer. Researchers have been studying and analysing the risk factors that contributing to the onset of testicular cancer, including genetic predisposition, exposure to certain environmental factors, and history of undescended testicles. Three researchers have been successful in identifying the potential risk factors, however the exact causes leading to testicular cancer are still being pursued.

Various studies have shown that men with a family history of testicular cancer or with certain genetic conditions, such as Klinefelter syndrome, tend to have an increased risk of developing the disease. Additionally, factors such as exposure to ionizing radiation and endocrine-disrupting chemicals have been identified as potential contributors to onset of testicular cancer. Understanding the causes of testicular cancer is needed for developing of effective prevention strategies and early detection methods. By identifying the underlying factors that increase the risk of this disease, researchers can better tailor screening recommendations and interventions to high-risk individuals.

In terms of symptoms, testicular cancer often presents as a painless lump or swelling in the testicle. A major warning sign includes the feeling of heaviness in the scrotum, pain or discomfort in the testicle or scrotum, and changes in size or shape of the testicle. The impact of a cancer diagnosis extends beyond the physical aspects, and addressing the emotional well-being of patients is an integral part of their overall care. By gaining a deeper understanding of the causes and symptoms of testicular cancer, researchers and healthcare providers can work towards prevention, early detection, and patient-centered care.

Innovations in Cancer Detection Technology: The Promise of Microstrip Antennas

The integration of microstrip antennas into medical diagnostics has dawned a new era in cancer detection technology. These antennas have demonstrated their potential not only in testicular cancer detection but also in various fields of medical diagnostics. Their non-invasive, cost-effective, and accurate measurement capabilities have positioned them as a promising tool for the early cancer detection. In the realm of cancer diagnosis, early detection plays a critical role in determining the success of treatment and patient outcomes. The use of microstrip antennas for detecting changes in tissue properties associated with cancer presents a revolutionary approach to cancer diagnostics. By harnessing microwave frequencies to assess tissue dielectric properties, microstrip antennas offer a novel method for determining abnormalities linked to cancer.

The potential impact of microstrip antennas extends beyond testicular cancer to encompass other types of cancer. Their non-invasive nature and ability to provide precise measurements make them a valuable technology tool for early detection of various cancer types. Moreover, the integration of microstrip antennas into wearable devices or medical implants holds promise for continuous monitoring and early intervention, both of which are crucial elements in effectively managing cancer. The advancements in this technology not only offer a more effective and accessible means of detecting cancer at early stages but also provides a means for personalized and targeted approaches to cancer treatment.

By embracing the innovation of microstrip antennas in cancer detection, the field of oncology is poised for a transformative shift towards more effective, accurate, and patient-centered care. The future of cancer detection technology lies in the relentless pursuit of innovative solutions, and microstrip antennas stand at the forefront of this promising frontier. The integration of microstrip antennas into medical diagnostics represents a significant leap forward in the pursuit for early cancer detection and improved patient outcomes.

Methodology:-

Microstrip Antenna Design for Testicular Cancer Screening

One of the major limitations in detecting testicular cancer using microstrip antennas is the large signal reflection from the skin. While the potential of microstrip antennas for testicular cancer screening is promising, overcoming certain technical challenges is important for their effective implementation in medical diagnostics. The issue of large signal reflection from the skin presents a significant technical hurdle that needs to be addressed to ensure accurate and reliable detection of testicular cancer.

Researchers and engineers involved in the field of medical technology are actively striving to develop innovative solutions to mitigate the signal reflection challenge. By exploring advanced signal processing techniques, such as adaptive filtering and beamforming, the objective is to enhance the ability of microstrip antennas to distinguish between skin reflections and cancer-related abnormalities within the testicular tissue. Additionally, the use of multi-frequency or wideband antenna designs offers the potential to improve the penetration depth and resolution of the antenna system, thus reducing the impact of skin reflections on the diagnostic accuracy.

Moreover, the designing of specialized coupling structures and impedance matching networks holds promise in minimizing the influence of skin reflections on the antenna performance. These tailored components can optimize the energy transfer between the antenna and the biological tissue, thereby mitigating the interference caused by skin reflections and enhancing the sensitivity of the antenna to detect even the subtle changes associated with testicular cancer.

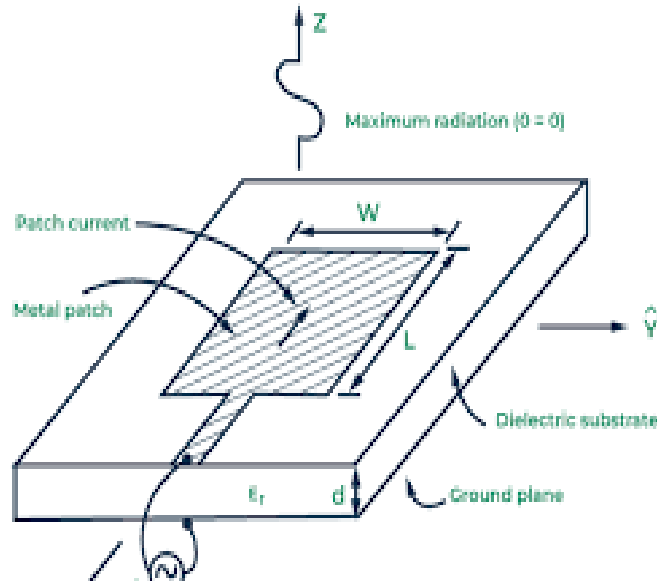

Fig.1:- Microstrip Antenna Design for TesticularCancerScreening.

Addressing the challenge of signal reflection from the skin is essential for realizing the full capability of microstrip antennas in testicular cancer screening. Figure 1 shows a microstrip antenna designed for testicular cancer screening. Through interdisciplinary collaboration and innovative engineering approaches, the advancement of antenna design for medical diagnostics continues to progress, bringing us closer to an era of precise and reliable cancer detection techniques. As the pursuit of overcoming technical obstacles in microstrip antenna design for testicular cancer screening continues, the potential for these antennas to revolutionize the early detection and management of testicular cancer remains a focal point of research and innovation in the field of medical diagnostics.

Evaluating the Accuracy and Efficacy of Antenna-Based Detection Methods

As the field of cancer detection technology continues to evolve, the accuracy and efficacy of antenna-based detection methods, particularly microstrip antennas, have become a subject of extensive research and evaluation. It is imperative to comprehensively assess the performance of these innovative diagnostic tools to ensure their reliability and potential impact on improving patient outcomes. In evaluating the accuracy of antenna-based detection methods for testicular cancer screening, researchers are conducting rigorous comparative studies to analyze the sensitivity, specificity, and overall diagnostic precision of microstrip antennas in detecting cancer-related abnormalities within the testicular tissue.

Comparative analyses against existing imaging techniques, such as ultrasound and magnetic resonance imaging, enable a comprehensive understanding of the strengths and limitations of antenna-based detection, thereby informing the integration of these technologies into clinical practice. Furthermore, the efficacy of antenna-based detection methods extends beyond diagnostic accuracy to encompass factors such as accessibility, cost-effectiveness, and patient experience. Assessing the usability and practicality of microstrip antennas in diverse clinical settings, including resource-limited environments, is critical for evaluating their potential impact on global cancer screening and early detection initiatives.

Along with their role in testicular cancer screening, the efficacy of microstrip antennas in detecting other types of cancer, like breast cancer and skin cancer, is also under scrutiny. Comparative effectiveness studies are needed for illustrating the broader applicability of antenna-based detection methods across a spectrum of cancer types and anatomical regions, thereby contributing to the advancement of comprehensive cancer screening strategies. As the research landscape continues to unfold, collaborative efforts between biomedical engineers, oncologists, and radiologists play a pivotal role in systematically evaluating the accuracy and efficacy of antenna-based cancer detection methods. This interdisciplinary approach fosters a comprehensive understanding of the technical, clinical, and practical considerations associated with the integration of these innovative technologies into standard clinical practice.

The evaluation of antenna-based cancer detection methods, particularly microstrip antennas, is an ongoing endeavor aimed at establishing their role as robust and reliable diagnostic tools in the early detection and management of cancer. Through methodical research, comparative analyses, and interdisciplinary collaboration, the potential impact of these technologies on improving patient outcomes and global cancer screening initiatives continues to be explored and refined.

Comparative analysis:-

Comparative Analysis of Traditional vs. Antenna-Based Detection Techniques: A Comprehensive Review

The comparative analysis of traditional imaging modalities and antenna-based detection methods is needed for gaining a comprehensive understanding of their respective strengths and limitations in cancer diagnostics. While traditional techniques such as ultrasound and magnetic resonance imaging have been established as primary tools for cancer detection, the emergence of microstrip antennas presents a compelling alternative with the potential to address existing limitations and enhance the overall efficacy of early cancer detection.

Comparative studies encompassing factors such as sensitivity, specificity, spatial resolution, and cost-effectiveness are needed for evaluating the utility of microstrip antennas in comparison to traditional imaging modalities. By systematically analyzing the performance of these technologies across varying clinical scenarios and cancer types, researchers aim to identify the distinct advantages and potential synergies that can be leveraged to optimize cancer screening and diagnostic workflows. Furthermore, the comparative analysis extends beyond technical parameters to include considerations of patient comfort, portability, and accessibility. Understanding the impact of these factors on patient experience and clinical practice is pivotal for aligning the adoption of antenna-based detection techniques with the evolving landscape of personalized and patient-centric healthcare.

Additionally, the comparative analysis serves as a catalyst for innovation, stimulating the refinement and development of hybrid approaches that integrate the strengths of both traditional and antenna-based detection methods. By harnessing the complementary capabilities of these technologies, synergistic solutions can be engineered to enhance the accuracy, efficiency, and overall impact of cancer diagnostics. As the field of cancer detection continues to evolve, the comparative analysis of traditional vs. antenna-based detection techniques serves as a cornerstone for the strategic integration of innovative technologies into clinical practice.

Future Perspectives in Non-Invasive Cancer Diagnostics

Looking ahead, the future of non-invasive cancer diagnostics holds tremendous promise, propelled by the continuous evolution of advanced technologies such as microstrip antennas. Beyond the current applications in testicular cancer screening, the potential of antenna-based detection methods to revolutionize non-invasive cancer diagnostics across various anatomical sites and cancer types is a focal point of ongoing exploration and innovation.

One of the key areas of future perspective lies in leveraging the versatility of microstrip antennas to enable multi-modal imaging, integrating the benefits of antenna-based detection with other imaging modalities to enhance the comprehensive assessment of cancerous lesions. By harnessing the synergies between different imaging techniques, clinicians can achieve a more nuanced understanding of tumor characteristics, facilitating tailored treatment strategies and improved prognostic evaluation. Moreover, the advent of artificial intelligence and machine learning presents an exciting frontier in the future of non-invasive cancer diagnostics, offering the potential to augment the capabilities of antenna-based detection methods with advanced algorithms for image interpretation and pattern recognition. The integration of AI-driven analytics holds promise for refining the accuracy and efficiency of cancer detection, providing valuable insights for early intervention and personalized treatment planning.

In parallel, the future perspectives in non-invasive cancer diagnostics also encompass the continuous refinement of microstrip antenna technology to optimize factors such as spatial resolution, signal-to-noise ratio, and real-time imaging capabilities. These advancements are poised to shape the next generation of antenna-based detection methods, further enhancing their applicability in diverse clinical settings, and extending their impact to a broader spectrum of cancer screening initiatives.

Furthermore, the integration of non-invasive cancer diagnostics into population-based screening programs and preventative healthcare strategies represents a significant avenue for future expansion. By leveraging the non-invasiveness and potential cost-effectiveness of antenna-based detection methods, there is an opportunity to extend

the reach of early cancer detection initiatives, particularly in resource-limited regions, thereby contributing to the global effort to reduce cancer mortality rates.

The future perspectives in non-invasive cancer diagnostics herald an era of innovation and multidisciplinary collaboration, driven by the ambition to develop advanced, patient-centric diagnostic solutions. With a focus on harnessing technological advancements, integrating complementary modalities, and expanding accessibility, the trajectory of non-invasive cancer diagnostics, empowered by antenna-based detection methods, is poised to redefine the landscape of cancer detection and management in the years to come.

Challenges and Limitations in the Implementation of Antenna Detection Systems

Despite the potential advancements and promising prospects of antenna-based detection methods in non-invasive cancer diagnostics, there are still several challenges and limitations that are yet to be addressed. The integration of antenna-based detection systems into clinical practice faces multifaceted challenges that encompass technological, logistical, and regulatory considerations. One of the primary technical challenges pertains to optimizing the spatial resolution and depth penetration of microstrip antennas to ensure accurate imaging across varying tissue densities and depths within the human body. Additionally, addressing concerns related to signal attenuation and interference in complex anatomical regions remains a critical area of focus for enhancing the reliability and precision of antenna-based cancer detection.

As healthcare facilities strive to adopt novel technologies, ensuring harmonized workflows and streamlined integration along with the electronic health records and image repository systems becomes essential for maximizing the clinical utility of antenna-based detection methods. Furthermore, regulatory considerations surrounding the approval, validation, and standardization of antenna-based diagnostic devices necessitate concerted efforts to align with stringent quality assurance standards and demonstrate the safety and efficacy of these technologies.

Beyond technical and logistical challenges, the successful implementation of antenna detection systems also hinges on addressing barriers related to cost-effectiveness, reimbursement policies, and training requirements for healthcare professionals. Striving to demonstrate the economic viability and long-term value proposition of antenna-based detection methods is integral for garnering support from healthcare payers and policymakers, thereby ensuring broader accessibility and sustainable integration into mainstream clinical practice.

Furthermore, investing in comprehensive training programs and educational initiatives for radiologists, oncologists, and allied healthcare professionals is essential for fostering proficiency in interpreting antenna-based imaging data and leveraging the full potential of these advanced diagnostic tools. By promoting a culture of continuous learning and skill development, healthcare institutions can empower their workforce to embrace and effectively utilize antenna detection systems in the realm of non-invasive cancer diagnostics.

While antenna-based detection methods hold immense promise for revolutionizing non-invasive cancer diagnostics, the successful integration of these systems into clinical practice necessitates proactive efforts to surmount a spectrum of challenges. From technical refinements and regulatory compliance to logistical harmonization and workforce readiness, addressing these considerations is pivotal in realizing the transformative potential of antenna-based cancer detection and advancing the frontiers of personalized and precision medicine.

Promising Advances in Testicular Cancer Early Detection Methods

The potential of AI-driven analytics integrated with antenna-based detection methods presents a paradigm shift in the landscape of non-invasive cancer diagnostics. By harnessing advanced algorithms for image interpretation and pattern recognition, AI has the capacity to improve the accuracy and efficiency aspects of cancer detection, providing invaluable insights for early intervention and personalized treatment planning. This convergence of technological prowess not only refines the capabilities of current detection methods but also opens new frontiers in the pursuit of precise and tailored diagnostic solutions for cancer patients.

Furthermore, the continuous refinement of microstrip antenna technology holds immense promise in optimizing spatial resolution, signal-to-noise ratio, and real-time imaging capabilities. These advancements are not only bound to shape the next generation of antenna-based detection methods but also promise enhanced applicability in diverse clinical settings, making strides towards extending the impact of cancer screening initiatives to a broader spectrum of healthcare scenarios. The integration of non-invasive cancer diagnostics into population-based screening programs

and preventative healthcare strategies represents a significant avenue for future expansion. Leveraging the non-invasiveness and potential cost-effectiveness of antenna-based detection methods can extend the reach of early cancer detection initiatives, particularly in resource-limited regions, contributing profoundly to the global effort to reduce cancer mortality rates. The future of non-invasive cancer diagnostics, empowered by antenna-based detection methods, heralds an era of innovation and collaboration, driven by the ambition to develop advanced patient-centric diagnostic solutions. By focusing on technological advancements, integrating complementary modalities, and expanding accessibility, the trajectory of non-invasive cancer diagnostics is set to redefine the landscape of cancer detection and management in the years to come.

Conclusion and Future Scope:-

While the concept of microstrip antennas for testicular cancer detection holds promise, overcoming the limitations through further research is crucial. By exploring advanced antenna designs, multimodal approaches, and machine learning techniques, researchers can potentially develop a reliable and user-friendly tool for early cancer detection. The ultimate objective is to create a safe, non-invasive, and effective screening method that can contribute to improved patient outcomes in the fight against testicular cancer.

In conclusion, microstrip antennas present a fascinating possibility for a non-invasive and potentially user-friendly approach to testicular cancer detection. Their compact, lightweight, and relatively inexpensive nature makes them suitable for wearable or handheld devices. Simulation tools allow researchers to optimize their design for specific applications. The ability to differentiate between healthy and cancerous tissues with sufficient sensitivity and specificity remains a challenge. The complexities of biological tissues and limited penetration depth at optimal frequencies add further complexity.

Future research holds the key to unlock the full capability of this method. Advanced antenna designs, multimodal approaches combining antenna data with other imaging techniques, and the power of machine learning for data analysis are promising areas for improvement. Rigorous clinical trials are essential to validate the efficacy and safety of microstrip antenna-based detection in real-world settings.

The significance of this review lies in the ability to revolutionize testicular cancer screening. A non-invasive method like this could encourage more frequent self-examinations and prompt medical attention. Microstrip antennas have the potential to become a valuable tool in the fight against testicular cancer, offering a painless, accessible, and potentially life-saving screening option for men.

References:-

1. Bharali DJ, Mousa SA, "Emerging nanomedicines for early cancer detection and improved treatment: current perspective and future promise." *Pharmacol Ther.* 2010 Nov;128(2):324-35. doi: 10.1016/j.pharmthera.2010.07.007. Epub 2010 Aug 10. PMID: 20705093.
2. Chakaravarthi G, Arunachalam K, "A compact microwave patch applicator for hyperthermia treatment of cancer." *Annu Int Conf IEEE Eng Med Biol Soc.* 2014;2014:5320-2. doi: 10.1109/EMBC.2014.6944827. PMID: 25571195.
3. André Vander Vorst; Arye Rosen; Youji Kotsuka, "RF/Microwave Interaction with Biological Tissues", Wiley-IEEE Press, 2006 <https://ieeexplore.ieee.org/book/5201916>
4. Foster KR, Schwan HP, "Dielectric properties of tissues and biological materials: a critical review." *Crit Rev Biomed Eng.* 1989;17(1):25-104. PMID: 2651001. <https://pubmed.ncbi.nlm.nih.gov/2651001/>
5. David M. Pozar, Daniel H. Schaubert, "Microstrip Antennas: The Analysis and Design of Microstrip Antennas and Arrays", Wiley-IEEE Press; 1st edition, 1995. <https://ieeexplore.ieee.org/book/5263382>
6. D. Pattar, P. Dongaokar, N. S. L and S. Amith, "Design and Implementation of Metamaterial Based Patch antenna," 2020 IEEE International Conference for Innovation in Technology (INOCON), Bangluru, India, 2020, pp. 1-4, doi: 10.1109/INOCON50539.2020.929822 <https://ieeexplore.ieee.org/document/9298225>
7. N. Ali and J. Ahmed, "Microstrip Patch Antenna Design For Breast Cancer Detection," 2022 International Conference on Engineering & MIS (ICEMIS), Istanbul, Turkey, 2022, pp. 1-4, doi: 10.1109/ICEMIS56295.2022.9914365.
8. R. Top, Ünlü Y., Gültekin S. S., and D. Uzer, "Microstrip Antenna Design with Circular Patch for Skin Cancer Detection", *AEM*, vol. 8, no. 2, pp. 71–76, Mar. 2019.

9. M.Leeban Moses, C.Raju and Ajin R Nair, "Detection of skin Cancer using PIFA antenna", IOP Conf. Series: Materials Science and Engineering 764 (2020) 012031 IOP Publishing doi:10.1088/1757-899X/764/1/012031
10. I. Jahan and A. Kabir, "Microstrip Patch Antenna for Breast Cancer Detection," 2021 5th International Conference on Electrical Information and Communication Technology (EICT), Khulna, Bangladesh, 2021, pp. 1-6, doi: 10.1109/EICT54103.2021.9733480.