



Journal Homepage: - www.journalijar.com
**INTERNATIONAL JOURNAL OF
 ADVANCED RESEARCH (IJAR)**

Article DOI: 10.21474/IJAR01/5136
 DOI URL: <http://dx.doi.org/10.21474/IJAR01/5136>



RESEARCH ARTICLE

THE ANALYSIS OF OPERATIVE PARTS OF A MINI ROTARY CULTIVATOR.

M. Mamuladze¹ and N. Beridze².

1. Associate Professor, Batumi Shota Rustaveli State University.
2. Assistant professor, Batumi Shota Rustaveli State University.

Manuscript Info

Manuscript History

Received: 11 June 2017
 Final Accepted: 13 July 2017
 Published: August 2017

Key words:-

Rotary, Tiller blades, Cultivation blades

Abstract

This study seeks to establish and analyze the mathematical models of the plowing force and trajectory curve for tiller blades and cultivation blades of a rotary cultivator. Both blades are widely used in Word. To ensure good efficiency and uniform resistance of the plow to soil, the blade must be protected from intertwinning. The theoretical and calculated cutting angles are 85.88° and 85.10° , the edge-curve angles are 55.00° and 56.18° . The rear of well designed plowing blade does not cause any friction with the soil. The curve of plowing shows that when the relief angle of the tiller blades is 25° , the turning and the throwing have good performance. When the relief angle of the cultivation blade is 10° , the impact force and the crashing force of the blade into the soil will be minimized during plowing.

Copy Right, IJAR, 2017,. All rights reserved.

Introduction:-

Mini cultivator (fig. 1) that work the soil generate some forces between the tiller blades and the soil, such as the compression of the soil, the resistance of the soil to its being cut, the adhesive forces on the soil and abrasive forces with the soil, among others. Several researchers have been interested in establishing the relationships among several design variables and the power requirement of rotary tillers.

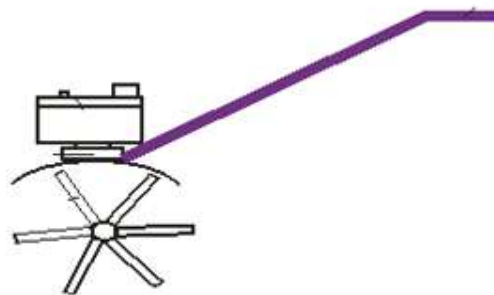

Fig.1:- Mini cultivator

Corresponding Author:- M. Mamuladze.

Address:- Associate Professor, Batumi Shota Rustaveli State University.

Ghosh model- A dimensional analysis of the torque requirement under different operating conditions was performed by developing a dimensional formula using the angular velocity of the rotor, the depth of working, the velocity of travel, the soil bulk density, the soil cohesion, the acceleration due to gravity and the soil particle size as independent variables. For a given soil, the moisture content and compaction conditions in the field, the forward speed of travel, are related in a dimensional equation:

$$T_r = K(n)^b(h)^c(\gamma)^d \quad (2)$$

Where T_r - torque, in kg-cm

K-constant

h-depth of working, in cm

γ -forward speed of travel, in cm/s

n-rotary speed, in rpm

b,c,d-powers of unknown value

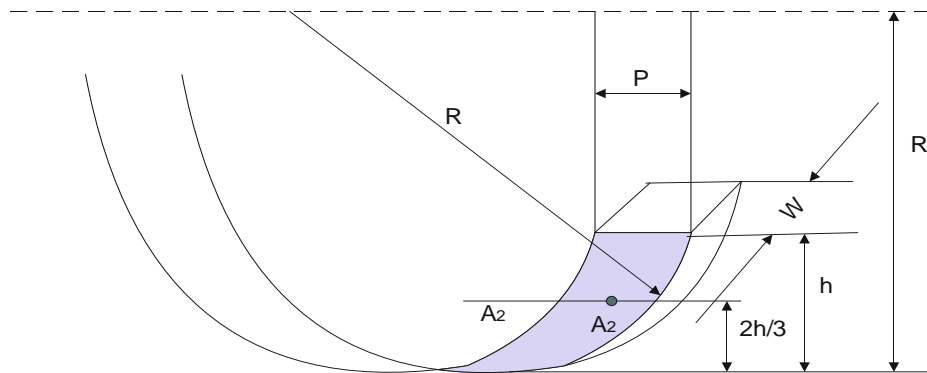

Fig. 2:- force due to soil-soil shear

Gupta model- Based on the predicted behavior of saturated soil under impact loading and pure shear, a mathematical model to predict the power requirement of a rotary tiller has been developed. The torque required by a rotary tiller is based on the following operations. The impact cutting of the saturated soil by the rotary tiller initially starts with compression. When the cutting speed is high, compression is very quickly followed by impact shear.

Force required to cut the soil in $NF_{CS} = \sigma_{is}A_1$ (3):-

Where σ_{is} represents the impact shear stress to cut the soil. A_1 is the total wetted area of the cutting surface of the tool, in mm², and σ_{is} - is given by the equation.

$$\sigma_{is} = \left[\frac{u_s \eta_{is}}{2R \cos^{-1} \left[\frac{R-h}{R} \right]} \right]^{n_{is}} + \sigma_{yis} \quad (4)$$

Where σ_{yis} - yield stress impact shear

n_{is} -exponent=1.512

η_{is} - coefficient of viscosity ($2,8 \cdot 10^4, N - S/m^2$)

u_s - cutting velocity, in m/s

(2) Torque required to throw the cut soil slice The cut soil slice is thrown away by the

centrifugal action of the rotating blades: Centrifugal force in N $F_e = \frac{m_s u_s^2}{R}$ (5)

With reference to figure 1:

$$m_s = \frac{hPw\rho_s}{g} \quad (6)$$

Where m_s -mass of the soil slice in kg, P- tilling pitch in mm and ρ_s -specific weight of the saturated soil in N/mm²

(3) Torque required to overcome soil-metal friction Normal force N that acts on the tool is equal to weight of cut soil slice given by

$$N = hPw\rho_s \quad (7)$$

Force F_1 required to overcome soil-metal friction is given by

$$F_1 = hPw\rho_s \mu_k \quad (8)$$

where μ_k - kinetic coefficient of soil-metal friction. (4) Torque required to overcome soil-soil sliding friction.

During cutting with the rotary tiller, the cut soil slice is separated from the uncut soil by pure shearing or soil-soil sliding. Equation 9 describes the behavior of the saturated soil under pure shear, according to the experiments conducted in a coaxial viscometer.

$$\gamma_0 = \frac{-d\gamma}{dr} = \left[\frac{1}{\mu_{PS}(\tau - \tau_y)} \right]^{\frac{1}{n_{PS}}} \quad (9)$$

The shearing rate γ_0 is a function of the speed of rotation of the blade and the depth of working:

$$\gamma_0 = \frac{V_p}{h}$$

Substituting the value γ_0 of into Eq. 9, yields,

$$\tau = \eta_{PS} \left(\frac{V_p}{h} \right)^{n_{PS}} + \tau_y \quad (10)$$

Where

γ_0 -shear rate, in Pa

τ - shearing stress under pure shear, in Pa

τ_y -yield stress under pure shear, in Pa

V_p - peripheral speed of the rotor, in m/s

h - depth of working, in cm

n_{PS} - exponent=0,3

η_{PS} - coefficient of viscosity=49,8 N.s/m²

The rate of attrition of the tiller blade depends on the workload of the tractor. According to the analysis by Yamada, four major factors are correlated with the attrition of the tiller blades - (1) the conditions of the soil; (2) the quality of the tiller blades; (3) their mechanical conditions, and (4) the operating conditions. The farming conditions are related to the mechanics of the soil. A survey of the soil on farms, conducted by the Kogi Agriculture and Forestry Technology Institute (Japan) showed that a higher percentage of sand and silt causes faster attrition of the tiller blades.

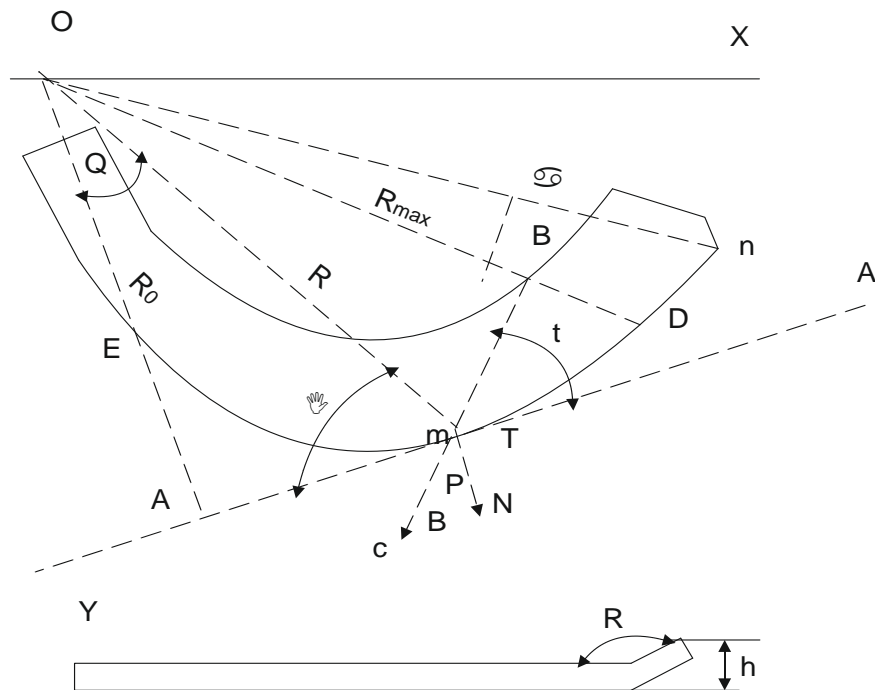

Fig 3:- The shapes' scoop-surface and outing function of tiller blades

The attrition of blades depends on the quality of the material from which they are made, their solidity, the emulsion with which they are sprayed, the heat treatment undergone, their depth, toughness and shape, the cutting angle, the edge of the blades, their curvatures, and the angle of scoop. The attrition of a blade is correlated with mechanical output forces, the arrangement of the tiller blade, the repeated crushing of the soil, and other factors. The operating conditions also depend on the tilling area, the compression of the soil, the impact loads, the resistance due to abrasion and sharpening

The geometry of tiller blades is considered to be the most important factor in their design because both the shape of the blade tip and the lengthwise of the tiller blades facilitate cutting. The width of the blade tip exceeds the lengthwise of the blade. The contact between the blade and the soil moves slowly from the handle near the center of the shaft to the length of the blade. The tip of the blade at the boundary between the lengthwise of the blade and the blade tip cuts the intact grass. The grass can also be thrown away or torn off by the outward rotation. This type of blades performs well in the soil in Evrope and is extensively used in Georgia. Figure 2 shows both the blade tip and the lengthwise of the blade, as segments ED and Dn, respectively in Fig. 3. The lengthwise of the blade must meet two conditions. One is the absence of intertwisting and the other is a low drag force during cultivation. The cutting conditions are $T \geq F$ (Fig. 2). $T = Ncot\tau$; $F = Ntan\varphi$; $cot\tau > tan\varphi$; $\tan(90^\circ - \tau) > tan\varphi$; $90^\circ - \tau > \varphi$; $\tau < 90^\circ - \varphi$.

Where φ is the friction angle of the rootstock with respect to the blade edge. The lengthwise of the blade is part of an Archimedean curve whose parametric equation is,

$$R = R_0(1 + K\theta) \tag{11}$$

$$R_0 = \sqrt{R_{max}^2 + S_x^2 - 2S_x\sqrt{2R_{max} \cdot h_{max} - h_{max}}} \tag{12}$$

where

R_0 - initial blade helical line radius, in cm

R - otation radius of the blade, in cm

R_{max} - maximum tilling radius, 24-26 cm

S_x - thickness of soil in transverse section, in cm

h_{max} - maximum depth of working, in cm

θ_{max} - maximum central angle , 35-45°

T- cutting force, in N

F- friction force, in N

Take i as the angle between AA' and line Om;

$$i = \tan^{-1} \frac{1 + K\theta}{K} \tag{13}$$

The angle i increases with the angle θ , but the angle τ decrease, as determined by graphical analysis. The low τ positively affects the cutting work. Equations (14), (15), and (16) present another closed solution (Sakai et al., 1976; Sakai, 1978) which can be obtained using polar coordinates on the spiralline (Figure 4). These equations have the same meaning as Eq. (13).

$$r = r_0 \sin^{\frac{1}{K}} \alpha_0 \{ \alpha_0 + K\theta \} \tag{14}$$

$$\alpha' = \alpha_t + \left[\left\{ \tan^{-1} \frac{n\pi\sqrt{h + 2R - h}}{30\gamma - n\pi(R - h)} \right\} + 90 \right] \tag{15}$$

$$r = r_0 e^{-(cot\alpha')\theta} \tag{16}$$

Where

r_0 – maximum radius at the tip point of the edgecurve, in cm

α_0 – edge-curve angle at the tip point where r is maximum

r - calculated radius of the spiral, in cm

γ - forward speed of travel, in cm/sec

α' - 4° or great than α_t

First, use Eq. (17) to calculate angle β (Fig.3) Angle β_1 can be easily found by using Eq. (18).

First, use Eq. (17) to calculate angle β (Fig.3) Angle β_1 can be easily found by using Eq. (18).

$$\beta = \cos^{-1} \left\{ \frac{30V}{R} \sqrt{\frac{h(2R-h)}{(30V)^2 - 60n\pi V(R-h) + (Rn\pi)^2}} \right\} \tag{17}$$

$$\beta_1 = \beta \cdot V \tag{18}$$

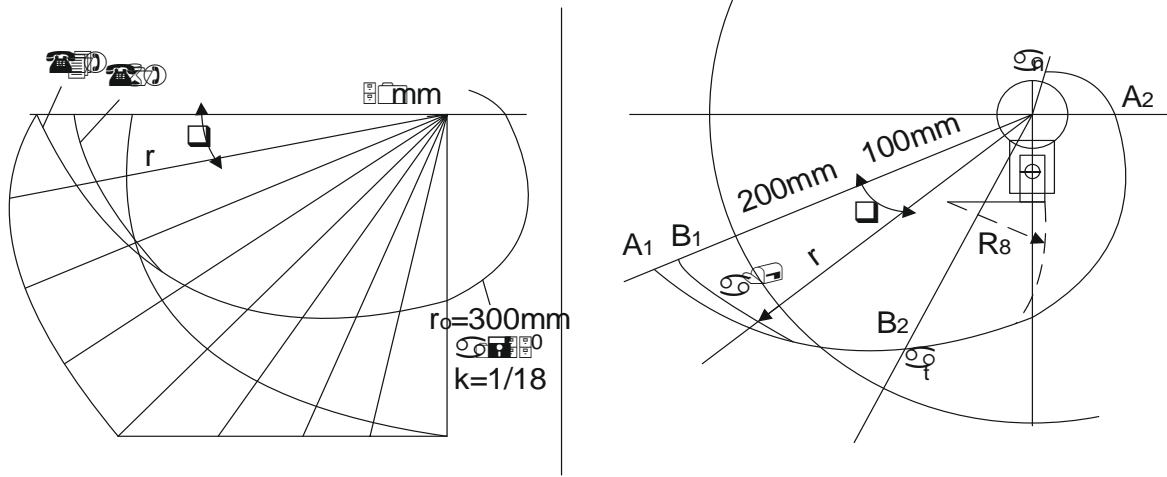

Fig. 3:- Planing design

Then, use Eq. (19) to calculate the forward speed of travel γ . The acceleration can be determined by Eq. (20) according to table 1.

Table 1:- Operational model for different types of tiller blades

| Blade tupe | v(cm/sec) | n (rpm) | γ^0 | a(cm/sec ²) |
|------------------------------|-----------|---------|------------|-------------------------|
| Cultivation blade | 20-30 | 300-400 | 5-10 | 0 |
| Cultivation broken bit blade | 30-40 | 250-300 | 10-15 | 2,3 |
| Cultivation wasteland blade | 40-60 | 150-250 | 15-20 | 0 |
| Tiller blade | 40-60 | 150-300 | 20-30 | 2,3 |
| Cutting blade | 20-30 | 250-500 | 20-30 | 2,3 |

$$\gamma = \frac{n\pi R \left[(n\pi c_1 - 30V) \cdot \tan \left(180^\circ - \gamma - \tan^{-1} \frac{-n\pi \sqrt{h(2R-h)}}{30V - n\pi c_1} \right) + n\pi \sqrt{h(2R-h)} \right]}{30 \sqrt{(30V - n\pi c_1)^2 + n^2 \pi^2 h(2R-h)} \cdot \tan \left(180^\circ - \gamma - \tan^{-1} \frac{-n\pi \sqrt{h(2R-h)}}{30V - n\pi c_1} \right)} \tag{19}$$

$$a = \gamma \frac{cm}{sec^2} \tag{20}$$

Finally, Eq. (21) was used to determine time t for cultivation and the parameters such as $A^2, B, r,$ and D can be determined from Eqs. (22), (23), (24), (25) and (26).

$$t = \frac{-(V + \gamma) + \sqrt{(V + \gamma)^2 + 2a\sqrt{R^2 - C^2}}}{a} \tag{21}$$

$$A^2 = \left\{ \sqrt{R^2 - C^2} - (V + \gamma)t - \frac{a}{2} t^2 \right\} \tag{22}$$

$$B = (V + \gamma)t \tag{23}$$

$$r = \sqrt{C^2 + A^2} \tag{24}$$

$$\theta = \sin^{-1} \left[\frac{C}{r} \right] - \frac{n\pi t}{30} \tag{25}$$

$$D = \frac{a}{2} t^2 \tag{26}$$

Conclusion:-

This study establishes and analyzes mathematical models of the plowing force and orientation curve of tiller blades and cultivation blades. To ensure good efficiency and uniform resistance of the plow to soil, the blade must be protected from intertwisting. The theoretical and calculated cutting angles are 85.88° and 85.10° and, the edgecurve angles are 55.00° and 56.18° , with the data in the literature. The rear of a well designed plowing blade does not cause any friction with the soil. The curve of plowing shows that when the relief angle of the tiller blades is 25° , the turning and the throwing have good performance. When the relief angle of the plowing blade is 10° , the impact force and the crashing force of the blade into the soil will be minimized during plowing.

References:-

1. Thakur, T. C. and R. J. Godwin.- The mechanic of soil cutting by a rotating wire. Journal of Terramechanics, 27 (4): 1990 Y.
2. Gupta, C. P. and R. Visvanathan- Power requirement of a rotary tiller in saturated soil. Transactions of the ASAE 36 (4): 1993 Y.
3. Sakai, J., Y. Shibata and T. Taguchi. Design theory of edge-curves for rotary blade of tractors. 1976 Y.